

UTILITY BATTERY CHARGERS

- * A12B Series Battery Charger / Power Supply
- * TPSD Battery Charger / Power Supply
- * A77D / A77DE Microprocessor Controlled SCR Battery Charger / Eliminator
- * ESCR125 Industrial Battery Charger
- * A96 130 VDC Switchmode Utility Rectifier / Battery Charger
- * A97 130 VDC Rack / Wall Mount Switchmode Utility Rectifier / Battery Charger
- * LDC Load Distribution Center

ENGINE STARTING BATTERY CHARGERS

- * ESCR Engine Starting Battery Charger
- * ESCR II Engine Starting Battery Charger
- * A46 / A46F Generator Set Float Battery Charger
- * USC High Frequency Ultra Series Charger
- * EC Engine Starting Automatic Float Battery Charger
- * A40 / A40F Series Engine Starting Battery Charger
- * A18J & A20R Engine Starting Battery Charger
- * A12B (Please Refer to Utility Battery Chargers Section for Data Sheet)

TELECOMMUNICATIONS BATTERY CHARGERS

- * LMDC Power Distribution Center
- * LTP Power System for Telecom Applications
- * LT12 High Frequency Telecom Inverter
- * LMHF Modular Switchmode Rectifier System
- * LMPs Modular Power System
- * TPM Systems Total Power Module Switchmode Rectifier Systems
- * A36D Rectifier / Power Supply
- * A12B (Please Refer to Utility Battery Chargers Section for Data Sheet)
- * TPSD (Please Refer to Utility Battery Chargers Section for Data Sheet)

MARINE BATTERY CHARGERS

- * A41 / A41F Marine Battery Charger
- * A40 / A40F Series Engine Starting Battery Charger
- * A46 / A46F Generator Set Float Battery Charger
- * A12B (Please Refer to Utility Battery Chargers Section for Data Sheet)
- * TPSD (Please Refer to Utility Battery Chargers Section for Data Sheet)
- * MSM Marine High Frequency Battery Charger

UNINTERRUPTIBLE POWER SYSTEMS

- * A-Series UPS System
- * A32P / A32S UPS System

MATERIAL HANDLING BATTERY CHARGERS

- * A39 Universal SCR Battery Charger
- * A45E Mag Amp Battery Charger

MINING, RAILROAD, SOLAR AND OTHER PRODUCTS

- * A75MD SCR Mine Battery Charger
- * A75R SCR Railroad Battery Charger
- * ESCR125 Industrial Battery Charger
- * SC Solar Charge Controller
- * A48 / A48B Centrifugal Fire Pump Battery Chargers
- * A63 - DC-DC Converter Systems
- * IX Series - High Frequency/ Hot Swap Inverter Systems
- * A31 - DC-AC Inverter
- * BI Battery Informer Series - Live Circuit Battery Testing
- * ARBS Automatic Redundant Battery Selector
- * BDC Battery Distribution Center

ACCESSORIES

- * Digital Combined Accessory Packages
- * Floor Stands
- * Drip Shields
- * Floor Mounting Kit
- * Wall Mounting Kit
- * DNP3.0 / Modbus Communication Board

RACK SYSTEM COMPONENTS

- * Relay Racks
- * CDPD Combination Distribution Panel
- * GCB / GB / CB Series Termination Buses and Lug Kits
- * BPK Series Single Pole Circuit Breaker Distribution Panel
- * BPKR Circuit Breaker Panel With Return Modbus
- * FPR Fuse Panels With Alarm & Optional Fuses
- * BP Battery / Load / Charger Disconnect Panel
- * LD Series Low Voltage Load Disconnect Panel
- * CE Counter EMF Panel
- * MP Series Meter Panels
- * DSA Digital Status Alarm Panel
- * Battery Tray
- * Blank Panels & Heat Baffle
- * Mount, Wire & Test
- * Protective Rear Covers

MISCELLANEOUS

- * Approval Agency Listings
- * Case Specifications
- * Float Battery Chargers Reference Guide
- * Manufacturer's Warranty Reference
- * 10 Year Warranty
- * Field & Service Rates
- * Order Form and Terms & Conditions



The Industry's Most Reliable Filtered Battery Charger / Power Supply



Standard



16 Series CAP
W/Breakers



46 Series CAP
W/Breakers



The La Marche model A12B Series Filtered Battery Chargers / Power Supplies are engineered for the demanding requirements of SwitchGear applications, Process Controls and Communications. The magnetic amplifier circuitry is designed to carry continuous and intermittent loads up to the maximum rated output. Its robust design and unmatched reliability has made this workhorse the standard in the industry and with its customizing features.

Refer to Digital C.A.P. System Data Sheet for complete details.

Standard Features

- Magnetic Amplifier Circuitry
- Separate Float and Equalize Potentiometers provide simple and precise DC Voltage calibration
- Float/Equalize Mode Switching
- Float and Equalize Lights
- Automatic AC Voltage Compensation
- +/- 0.5% DC Voltage Regulation
- Fused AC input and DC output protects Battery and Charger/Power Supply
- Analog DC Ammeter and DC Voltmeter
- Current Limiting Circuitry prevents overload and provides current control from 50 to 120% of rated output (factory set at 115%)
- Output Filtered (With or Without a Battery) - 30mV RMS for Single Phase Models and 100mV RMS for Three Phase Models
- AC Power Failure Relay with Form "C" Contacts
- AC Surge Suppression (MOV)
- NEMA Type 1 Enclosure / IP20
- UL 1012 & C-UL Listed (UL 1481 Listing available)
- 10-year Limited Warranty



Specifications

ELECTRICAL

- **AC Input Voltages**
Single Phase 60Hz: 120, 208, 220, 240, 480 or 600
Single Phase 50Hz: 220/240, 380 or 415
Three Phase 60Hz: 208, 240, 480 or 600
Three Phase 50Hz: 220/240, 380 or 415
Voltage range: +/- 10% from nominal
Frequency range: +/- 5%
- **Power Protection**
AC Fuse, DC Fuse and Current Limit Protection
- **DC Output Amps and Voltages**
DC Amps: 3 to 400 amperes
DC Volts: 12, 24, 48, 130VDC (Others available such as 32, 36 & 260VDC)
- **Output Filtering (With or without a battery)**
30mV RMS for single phase models and
100mV RMS for three phase models
- **DC Voltage Regulation**
Plus or minus 0.5% of setting from no load to full load over the specified input voltage, frequency and ambient temperature ranges.

ENVIRONMENTAL

- **Operating Temperature**
0° to 50°C (32° to 122°F)
- **Storage Temperature**
-40° to 85°C (-40° to 185°F)
- **Relative Humidity**
0 to 95% (non-condensing)
- **MTBF**
Exceeds 250,000 Hours
- **Dimensions**
Overall dimensions and weights are listed on the last page of this Data Sheet. Case specifications are subject to change due to innovative product development and design. When space requirements are critical, please consult the factory.
- **Mounting**
Floor or wall units are available. Mounting flanges are supplied as integral part of cabinet back plate on wall mounted models.
- **Finish**
Pretreated with a seven stage iron phosphate wash, sealer and deionized rinse. Then coated with an environmentally safe and durable ANSI 61 gray Polyester TGIC Minitel powder finish.

AGENCY APPROVALS

- **UL Battery Charger**
File E 319318, Guide BBML
UL Std. No. 1012
- **C-UL Battery Charger**
CAN/CSA
Std. C22.2 No. 107-2
- **UL Fire Alarm System Power Supply**
File S2768, Guide UTRZ
UL Std. No. 1481
Must Specify Accessory Code 09A
24V output, 240V or less, 60Hz single phase input only.

Notes:
All models where appropriate will carry the U.L. and C-U.L. Battery Charger listing. When U.L. Fire Alarm System Power Supply Listings are required, you must specify this requirement at the time of order. Not all models can be U.L. approved. Accessories, type of charger and rating will determine U.L. approval. Consult our factory if U.L. approvals are required.

Optional Accessories

ALARM & CONTROL

- **16 Series** (Refer to Digital C.A.P. Systems Data Sheet for complete details)
LED C.A.P. Systems common features:
Selectable Display, Multi-Mode Equalize Timer
Equalize Light
AC Power Failure Relay w/ (2) sets Form "C"
Low DC Current Alarm w/ (2) sets Form "C"
Low DC Voltage 1 Alarm w/ (2)sets Form "C" & Adjustable Time Delay (0-255 sec) (Except Ground Detection Alarms).
Multi-Mode Equalize Timer with Light adjustable from 1-144 hrs with five selectable modes and various failure alarm & lights.
- **46 Series** (Refer to Digital C.A.P. Systems Data Sheet for complete details)
2 Line LCD C.A.P. Systems common features:
Selectable Display, Multi-Mode Equalize Timer
Equalize Light
Float Light
AC Power Failure Relay w/ (2) sets Form "C" (Except 46Q)
Low DC Current Alarm w/ (2) sets Form "C"
Low DC Voltage 1 Alarm w/ (2)sets Form "C" & Adjustable Time Delay (0-255 sec) (Except Ground Detection Alarms).
Multi-Mode Equalize Timer with Light adjustable from 1-144 hrs with five selectable modes and various failure alarm & lights.
Discrete Alarm LEDs (46A & 46B) Available
- **46A** Discrete Alarm LEDs (with Ground Detection)
For use with CAP systems 46J, 46U, 46Q, 46T
- **46B** Discrete Alarm LEDs (w/o Ground Detection)
For use with CAP systems 46E, 46P, 46G, 46L
- **03N** Low DC Current Alarm & Light w/ (1) set Form "C" contacts
- **04J** Electronic Equalize Timer Multi-Mode adjustable from 2-144hrs with five selectable modes; Standard, 7-day, 14-day, 30-day and Equalize after Low DC Voltage.
- **050** Ground Detection Switch 3-position with DC Voltmeter indication (130VDC models utilizes two switches)
- **051** Ground Detection Alarm with Reset Pushbutton and (1) set form "C" Positive and (1) set form "C" Negative contacts
- **052** Ground Detection Lights (Positive and Negative)
- **053** Ground Detection Switch & Lights (130VDC models utilizes two switches)
- **054** AC Power Failure Light
- **16C** Hi/Lo-2 Combination Alarm High/Low DC Voltage, Field Calibrations & Adjustments, Individual Lights and (2) Form "C" contacts for each alarm
- **10G** Forced Load Sharing (with same model number only)
- **103** Remote Sensing
- **20Q** Equalize Fan Control Relay

METERING & PROTECTION

- **011** AC Breaker Single Pole (120VAC only)
- **012** DC Breaker Single Pole
- **016** AC Breaker Two Pole

METERING & PROTECTION CONTINUED

- **017** DC Breaker Two Pole
- **01B** AC Breaker Three Pole (3-phase input only)
- **01M** DC Breaker two Pole High Interrupting - 22KAIC (up to 250VDC)
- **01C** AC Breaker two Pole High Interrupting - 65/35/18KAIC (240/480/600VAC)
- **01D** AC Breaker two Pole High Interrupting - 100/65/25KAIC (240/480/600VAC)
- **01F** AC Breaker three Pole High Interrupting - 65/35/18 KAIC (240/480/600VAC)
- **01G** AC Breaker three Pole High Interrupting - 100/65/25KAIC (240/480/600VAC)
- **06G** Zero Center Ammeter w/Battery & Load Terminals (under 250A units)
- **06L** AC Ammeter +/-2% accuracy (single phase)
- **06M** AC Voltmeter +/-2% accuracy (single phase)
- **14V** AC Voltmeter with switch (three phase)
- **14W** AC Ammeter with switch (three phase)
- **102** DC Blocking Diode
- **107** DC Surge Protectors (MOV's)
- **11L** Lightning Arrestor
- **217** Reverse polarity Protection & LED

MISCELLANEOUS

- **09A** UL1481 (24V output, 240V or less, 60Hz single phase)
- **092** Tropicalization (magnetics only) Single Phase
- **093** Tropicalization (magnetics only) Three Phase
- **10B** USCG (U.S. Coast Guard) Accessories
- **10L** Battery & Load Terminals (under 250A units)
- **11F** 30mV Filtering for 3-phase units
- **38G** ABS (American Bureau of Shipping) Modifications
- **38J** ABS (38G) & USGC (10B) Single Phase
- **38K** ABS (38G) & USGC (10B) Three Phase
- **11V** Temperature Compensation (Internal Probe)
- **11W** External Temperature Probe 22 ft
- **38D** Copper Ground Bus Bar
- **095** Heat Shrinkable Wire Markers with Point to Point Wiring Diagram
- **09W** Heat Shrinkable Wire Markers with Electrical Schematic
- **09L** Physical Parts Location Drawing
- **097** SIS Wire (#16 AWG and larger) Markers
- **080** Drip Shield (must order separately)
- --- Floor Stand (must order separately)
- --- Special NEMA (3R, 4, 4X and 12) and IP Rated Enclosures

COMMUNICATION PROTOCOLS (Offered only with 46 series C.A.P.)

- **21J** IEC 61850 Ethernet
- **21P** DNP 3.0 Communications RS232/RS485/Ethernet
- **21Q** MODBUS Communications RS232/RS485/Ethernet
- **21S** MODBUS RTU Serial Data Port
- **21X** SNMP

Notes: Discrete Alarms are not available in conjunction with Digital C.A.P.(Combined Accessory Package) systems. Typically, when ordering two or more discrete components, the Digital C.A.P.system listed above provides a more economical approach.
Case sizes may differ depending on optional accessories and/or 50Hz input. Please consult factory when dimensions are critical.

TABLE OF CONTENTS

Please consult factory for other available cell ranges if desired range not shown.

Must specify only one battery type and number of cells from range shown above.

	Model Number	DC Amps	DC Fuse Size (Amps) ⁽¹⁾	AC Input Phase	AC Input Current Draw @ 100% Load (Amps) ⁽²⁾										Std. Case Size ⁽⁴⁾	Shipping Weight (Approximate)	
					60Hz Units					50Hz Units						lbs	kgs
					A 120	D 208	L 220	B 240	C 480	ZD 600	B L 240 / 220		G 380	J 415			
12 volt systems (6L, 9 or 10NC)	A12B-3-12V	3	10	1	0.8	0.4	0.4	0.4	---	---	0.4 / 0.4	---	---	7	60	28	
	A12B-6-12V	6	15	1	1.5	0.9	0.8	0.8	---	---	0.8 / 0.8	---	---	7	70	32	
	A12B-10-12V	10	20	1	2.5	1.4	1.4	1.3	---	---	1.3 / 1.4	---	---	7	80	37	
	A12B-15-12V	15	25	1	3.8	2.2	2.1	1.9	---	---	1.9 / 2.1	---	---	3	90	41	
	A12B-20-12V	20	30	1	5	2.9	2.7	2.5	---	---	2.5 / 2.7	---	---	3	95	44	
	A12B-30-12V	30	40	1	7.5	4.3	4.1	3.8	1.9*	1.6*	3.8 / 4.1	2.4*	2.2*	3	105	48	
	A12B-40-12V	40	60	1	10	5.8	5.5	5	2.5*	2.1*	5 / 5.5	3.2*	2.9*	6	155	71	
	A12B-50-12V	50	80	1	13	7.2	6.8	6.3	3.1*	2.6*	6.3 / 6.8	4.0*	3.6*	6	170	78	
	A12B-60-12V	60	80	1	15	8.7	8.2	7.5	3.8*	3.1*	7.5 / 8.2	4.7*	4.3*	6	180	82	
A12B-75-12V	75	100	1	19	11	11	9.4	4.7*	3.9*	9.4 / 11	5.9*	5.4*	6	225	103		
A12B-100-12V	100	150	1	25	14	14	13	6.3*	5.2*	13 / 14	7.9	7.2	8A	315	143		
	100	150	3	---	7.5	7.1	6.5	3.3*	2.7*	6.5 / 7.1	4.1*	3.8*	8A	325	148		
24 volt systems (12L, 18, 19 or 20NC)	A12B-3-24V	3	10	1	1.5	0.9	0.8	0.8	---	---	0.8 / 0.8	---	---	7	70	32	
	A12B-6-24V	6	15	1	3	1.7	1.6	1.5	---	---	1.5 / 1.6	---	---	3	85	39	
	A12B-10-24V	10	20	1	5	2.9	2.7	2.5	---	---	2.5 / 2.7	---	---	3	95	44	
	A12B-15-24V	15	25	1	7.5	4.3	4.1	3.8	1.9*	1.6*	3.8 / 4.1	2.4*	2.2*	3	100	46	
	A12B-20-24V	20	30	1	10	5.8	5.5	5	2.5*	2.1*	5 / 5.1	3.2*	2.9*	3	120	55	
	A12B-25-24V	25	35	1	13	7.2	6.8	6.3	3.1*	2.6*	6.3 / 6.8	4.0*	3.6*	3	135	62	
	A12B-30-24V	30	40	1	15	8.7	8.2	7.5	3.8*	3.1*	7.5 / 8.2	4.7*	4.3*	3	145	66	
	A12B-35-24V	35	50	1	18	11	9.6	8.8	4.4*	3.7*	8.8 / 9.6	5.5*	5.1*	6	190	87	
	A12B-40-24V	40	60	1	21	12	11	10	5*	3.2*	10 / 11	6.3*	5.8*	6	205	93	
	A12B-50-24V	50	80	1	26	15	14	13	6.3*	5.2*	13 / 14	7.9	7.2	6	240	109	
	A12B-60-24V	60	80	1	31	18	17	15	7.5	6.3*	15 / 17	9.5	8.7	6	265	121	
	A12B-75-24V	75	100	1	38	22	21	19	9.4	7.8	19 / 21	12	11	70	400	182	
	A12B-100-24V	100	150	1	51	29	28	26	13	11	26 / 28	16	15	70	450	205	
		100	150	3	---	16	15	13	7	6	13 / 15	8.5	8	70	500	227	
	A12B-125-24V	125	200	3	---	19	18	17	8.1	6.8*	17 / 18	11	9.4	70	525	239	
	A12B-150-24V	150	200	3	---	23	22	20	9.8	8.2	20 / 22	13	12	72	630	286	
A12B-200-24V	200	250	3	---	30	29	26	13	11	26 / 29	17	16	27	825	375		
A12B-250-24V	250	300	3	---	38	36	33	17	14	33 / 36	21	19	27	880	400		
A12B-300-24V	300	400	3	---	46	43	40	20	17	40 / 43	25	23	27	940	427		
A12B-400-24V	400	600	3	---	61	57	53	26	22	53 / 57	33	31	47	1350	613		
48 volt systems (24L, 36, 37 or 38NC)	A12B-3-48V	3	10	1	3	1.7	1.6	1.5	---	---	1.5 / 1.6	---	---	7	85	39	
	A12B-6-48V	6	15	1	6	3.5	3.3	3	---	---	3 / 3.3	---	---	3	90	41	
	A12B-10-48V	10	20	1	10	5.8	5.5	5	2.5*	2.1*	5 / 5.5	3.2*	2.9*	3	140	64	
	A12B-15-48V	15	25	1	15	8.7	8.2	7.5	3.8*	3.1*	7.5 / 8.2	4.7*	4.3*	3	180	82	
	A12B-20-48V	20	30	1	21	12	11	10	5*	4.2*	10 / 11	6.3*	5.8*	6	205	93	
	A12B-25-48V	25	35	1	26	15	14	13	6.3*	5.2*	13 / 14	7.9	7.2	6	240	109	
	A12B-30-48V	30	40	1	31	18	17	15	7.5	6.3*	15 / 17	9.5	8.7	6	265	121	
	A12B-40-48V	40	60	1	41	24	22	21	10	8.4	21 / 22	13	12	6	275	125	
	A12B-50-48V	50	80	1	51	29	28	26	13	11	26 / 28	16	15	8A	355	161	
	A12B-60-48V	60	80	3	---	18	17	16	7.8	6.5*	16 / 17	9.9	9	8A	400	182	
	A12B-75-48V	75	100	3	---	23	22	20	9.8	8.2	20 / 22	13	12	72	525	239	
	A12B-100-48V	100	150	3	---	30	29	26	13	11	26 / 29	17	16	72	625	284	
	A12B-125-48V	125	200	3	---	38	36	33	17	14	33 / 36	21	19	72	700	318	
	A12B-150-48V	150	200	3	---	46	43	40	20	17	40 / 43	25	23	27	850	386	
	A12B-175-48V	175	250	3	---	53	50	46	23	19	46 / 50	29	27	27	1000	454	
	A12B-200-48V	200	250	3	---	61	57	53	26	22	53 / 57	33	31	27	1150	522	
A12B-250-48V	250	300	3	---	76	71	66	33	28	66 / 71	42	38	47	1400	635		
A12B-300-48V	300	400	3	---	91	86	79	40	33	79 / 86	50	46	47	1700	772		
A12B-400-48V	400	600	3	---	<i>121</i>	<i>114</i>	<i>105</i>	<i>53</i>	<i>44</i>	<i>105 / 114</i>	<i>66</i>	<i>61</i>	<i>47</i>	<i>1800</i>	<i>817</i>		
130 volt systems (54 through 60L, 92 through 97NC)	A12B-3-130V	3	10	1	7.5	4.3	4.1	3.8	---	---	3.8 / 4.1	---	---	3	140	64	
	A12B-6-130V	6	15	1	15	8.7	8.2	7.5	---	---	7.5 / 8.2	4.7*	---	3	140	64	
	A12B-10-130V	10	20	1	26	15	14	13	6.3*	5.2*	13 / 14	7.9	7.2	6	225	103	
	A12B-15-130V	15	25	1	38	22	21	19	9.4	7.8	19 / 21	12	11	6	250	114	
	A12B-20-130V	20	30	1	51	29	28	26	13	11	26 / 28	16	15	6	270	123	
		20	30	3	---	15	14	13	6.5	10	13 / 14	8.2	7.5	8A	360	164	
	A12B-25-130V	25	35	1	63	37	35	32	16	14	32 / 35	20	19	8A	355	161	
		25	35	3	---	19	18	16	8.1	13	16 / 18	10	9.4	8A	390	177	
	A12B-30-130V	30	40	1	75	44	41	38	19	16	38 / 41	24	22	8A	390	177	
		30	40	3	---	23	21	20	9.8	16	20 / 21	12	11	8A	430	196	
	A12B-35-130V	35	50	1	88	51	48	44	22	19	44 / 48	28	26	72	505	230	
		35	50	3	---	27	25	23	12	9.5	23 / 25	15	14	72	580	264	
	A12B-40-130V	40	60	1	<i>101</i>	58	55	51	26	21	51 / 55	32	29	72	550	250	
		40	60	3	---	30	29	26	13	11	26 / 29	17	16	72	625	284	
	A12B-50-130V	50	80	3	---	38	36	33	17	14	33 / 36	21	19	72	645	293	
	A12B-60-130V	60	80	3	---	46	43	40	20	17	40 / 43	25	23	27	865	393	
	A12B-75-130V	75	100	3	---	57	54	49	25	21	49 / 54	31	29	27	930	422	
	A12B-100-130V	100	150	3	---	76	71	66	33	28	66 / 71	42	38	27	1040	472	
	A12B-125-130V	125	200	3	---	94	89	82	41	34	82 / 89	52	48	47	1500	681	
	A12B-150-130V	150	200	3	---	<i>113</i>	<i>107</i>	<i>98</i>	<i>49</i>	<i>41</i>	<i>98 / 107</i>	<i>62</i>	<i>57</i>	<i>47</i>	<i>1800</i>	<i>817</i>	
A12B-175-130V	175	250	3	---	<i>132</i>	<i>125</i>	<i>114</i>	<i>57</i>	<i>48</i>	<i>114 / 125</i>	<i>72</i>	<i>66</i>	<i>47</i>	<i>1950</i>	<i>885</i>		
A12B-200-130V	200	250	3	---	<i>151</i>	<i>142</i>	<i>131</i>	<i>66</i>	<i>55</i>	<i>131 / 142</i>	<i>83</i>	<i>76</i>	<i>47</i>	<i>2100</i>	<i>953</i>		
A12B-250-130V	250	300	3	---	<i>188</i>	<i>178</i>	<i>163</i>	<i>82</i>	<i>68</i>	<i>163 / 178</i>	<i>103</i>	<i>95</i>	<i>47</i>	<i>2300</i>	<i>1044</i>		
A12B-300-130V ⁽³⁾	300	400	3	---	<i>226</i>	<i>214</i>	<i>196</i>	<i>98</i>	<i>82</i>	<i>196 / 214</i>	<i>124</i>	<i>113</i>	<i>47B</i>	<i>2400</i>	<i>1089</i>		
A12B-400-130V ⁽³⁾	400	600	3	---	<i>301</i>	<i>285</i>	<i>261</i>	<i>131</i>	<i>109</i>	<i>261 / 285</i>	<i>165</i>	<i>151</i>	<i>57</i>	<i>2550</i>	<i>1157</i>		

⁽¹⁾ Optional DC Breaker when

Case Specifications

Case No.	Overall Dimensions						Cable Entry (when facing unit)		
	Width		Depth		Height		AC input	DC output	Mounting
	in	mm	in	mm	in	mm			
3	15.375	391	11.000	279	23.750	603	RIGHT	LEFT	WALL / FLOOR
6	25.580	650	13.935	354	28.000	711	RIGHT / TOP / BOTTOM	LEFT / TOP / BOTTOM	WALL / FLOOR
7	14.250	362	10.625	270	19.875	505	RIGHT	LEFT	WALL / FLOOR
8A	27.200	691	15.250	387	32.500	826	RIGHT	LEFT	FLOOR
27	27.312	694	25.875	657	56.125	1426	TOP	TOP	FLOOR
47	38.000	965	39.375	1000	70.000	1778	TOP / BOTTOM	TOP / BOTTOM	FLOOR
47B	38.00	965	46.750	1188	71.125	1807	TOP / BOTTOM	TOP / BOTTOM	FLOOR
57	60.000	1524	36.000	914	80.000	2032	BOTTOM	BOTTOM	FLOOR
70	27.000	686	19.000	483	41.000	1041	RIGHT / BOTTOM	LEFT / BOTTOM	FLOOR
72	27.000	686	23.500	597	44.500	1130	RIGHT / BOTTOM	BOTTOM	FLOOR

Case sizes may differ depending on optional accessories and / or 50Hz input. Please consult factory when dimensions are critical. Dimensions shown above are overall footprint. Detailed dimensions drawings are available for mounting purposes.



46 Series (LCD)



16 Series (LED)

Refer to Digital C.A.P. System Data Sheet for complete details. Discrete alarm LEDs available.

Model Number Nomenclature

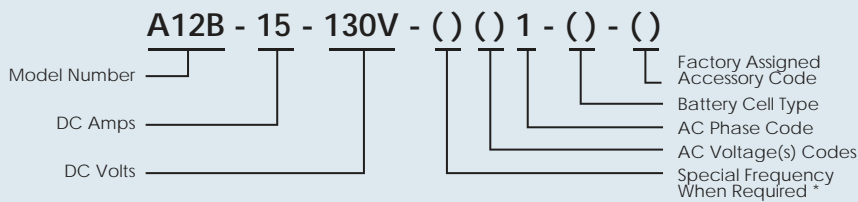

AC Phase Codes

- 1 - Single Phase
- 3 - Three Phase

AC Voltage Codes

- | | |
|-------------|--------------|
| 60Hz | 50Hz |
| A - 120 | BL - 240/220 |
| D - 208 | G - 380 |
| L - 220 | J - 415 |
| B - 240 | |
| C - 480 | |
| ZD - 600 | |

Special Frequency Code

- 5 = 50Hz
- * 60Hz standard unless special code is entered

Battery Cell Type

- L = Lead Acid
- LR = VRLA
- N = Nickel Cadmium

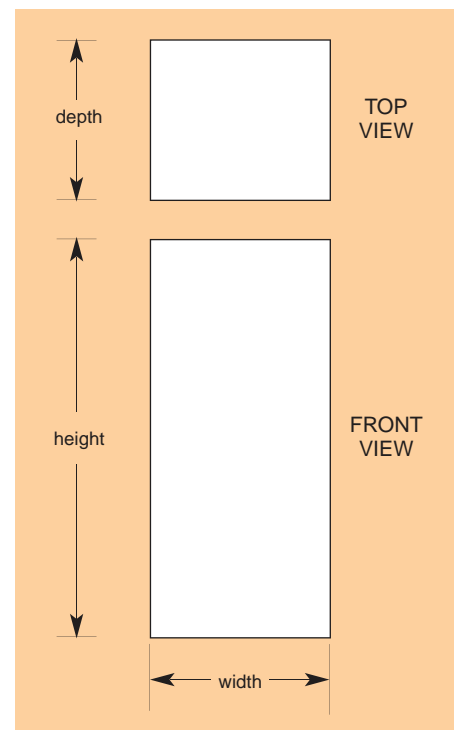

Ordering Information

When ordering, please specify:

- La Marche Model Number A12B
- Input Voltage, Frequency, Phase
- Number and Type of Battery Cells
- Amp Hour Capacity of Battery

- Intermittent DC Loads and Duration
- Continuous DC Load
- Allowable Recharge Time from Full Discharge (where applicable)
- Optional Accessories
- Verify AC Input Current Draw



Standard TPSD with LED Display



TPSD with LCD/VFD Display
(Option 550 / Option 551)



Standard Features

- LED Display
- Automatic DC Voltage Regulation
- Automatic AC Voltage Compensation
- Float/Equalize Mode Switching & LED Indicators (Adjustable FL / EQ voltage levels)
- Equalize Timer - adjustable from 1-144 hours with five selectable modes of operation (manual, automatic every 7, 14 or 30 days and equalize after sensing a low DC voltage)
- Positive and Negative Ground Detection
- AC & DC Surge Protection (MOV's)
- AC Input Circuit Breaker
- AC "ON" LED Indicator
- DC Output Circuit Breaker or Fuse
- Local & Remote Equalize Capability
- Local & Remote Output Voltage Sensing
- Output Load Current Sharing
- Internal Temperature Compensation
- Form "C" Relay Contacts with Adjustable Parameters:
 - Summary Alarm
 - AC Power Failure
 - Low DC Voltage
 - High DC Voltage
 - High DC Voltage Shutdown (HVSD)
 - Low Current
 - Positive and Negative Ground (not adjustable)
- Alarm Indicators:
 - Summary Alarm, Low DC Current, Low DC Voltage, High DC Voltage / HVSD, Ground Detection Fault
- U.L. 1012, C-UL Listed (for all 60Hz Units)
- 5-Year Limited Warranty

**TruPowerSource
Battery Charger / Power Supply**

The La Marche TPSD Battery Charger Series is designed to perform as a Power Supply / Battery Eliminator. This model incorporates Controlled Ferroresonant technology to provide the DC system with a dependable battery charger.

TPSD Battery Charger Series is engineered for the demanding requirements of Switchgear, Process Control, Oil and other DC power applications.

The design of the TPSD utilizes special magnetics that optimizes the performance of the charger. It's known for its High Efficiency, High Power Factor, Low Harmonic Distortion and inherent Current Limiting. The MTBF (Mean Time Between Failure) for this design is conservatively rated at 225,000 hours at 50 C°, assuring longevity and a higher return for your dollar.

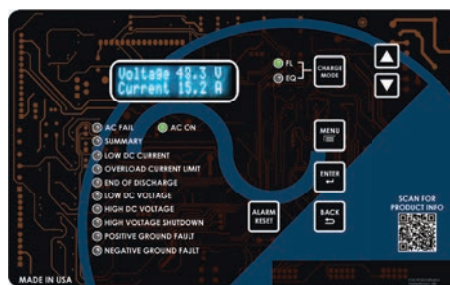

LCD Display
(Option 550)



VFD Display
(Option 551)

TPSD with LCD/VFD Display (Option 550/551)

TPSD units equipped with an LCD or VFD display support the same features as standard units plus the following additions:

- 2 Line LCD or VFD Display
- Digital adjustments for the Charger Output (No Potentiometers), Alarms and Communication Settings
- User-Friendly Menu structure with push-button switches for ease of navigation
- Completely Configurable Alarm System
 - Alarm Thresholds
 - Delays
 - Contact Operations (Latching/Non-latching)
- Alarm Contacts testing capability to confirm functionality (Via front panel or remotely with optional communication card)
- Additional LED Indicators
 - AC Power Fail
 - Overload Alarm
 - End of Battery Discharge
 - High Voltage Shutdown
- Quick Start Instructions on the Front Panel with QR Code Link to the Charger's Instruction Manual



Specifications

ELECTRICAL

- **AC Input**
Voltage range: +/- 10% from nominal
Frequency range: +/- 5%
- **Single Phase models:**
A1: 120VAC/1/60Hz
ABD1: 120/240/208VAC/1/60Hz
BLD1: 240/220/208VAC/1/60Hz
C1: 480VAC/1/60Hz
5BL1: 240/220VAC/1/50Hz
- **Three Phase models:**
BD3: 240/208VAC/3/60Hz
C3: 480VAC/3/60Hz
5G3: 380VAC/3/50Hz
- **DC Output**
DC Amps: 6 to 200 amperes
DC Volts: 24, 48 & 130VDC
DC Output Voltage Range - a chart is provided on the last page of this data sheet.
- **Output Filtering (With or without a battery)**
30mV RMS for single phase models and 100mV RMS for three phase models.
- **DC Voltage Regulation Steady-State**
± 0.5% of setting from no load to full load over the specified input voltage, frequency and ambient temperature ranges.
- **Dynamic Response (On Battery)**
Voltage transient < ± 5% over a step change in the load from 20% to 100%. Recovery Time 200 ms.
- **Audible Noise**
Less than 65dBA at any point 5 feet from any vertical surface of the enclosure.
- **Load Sharing**
Load sharing terminal located inside of unit. When connected, identical La Marche Units are forced to share the load within ± 5% for individual unit outputs greater than 15% of the rated output.
- **Temperature Compensation**
5 step curve @ -0.001V/cell/°C as shown below (consult factory for other compensation rates).

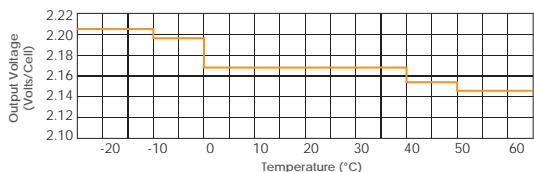

PROTECTION

- **Current Soft Start**
The output current will gradually increase after the charger is turned on, eliminating surges and overshoot.
- **Current Limit**
Electronic Current - Limiting Control Circuitry provides a digitally adjustable limit from 50 to 115% of the rated output current of the charger. Factory set at 115%.
- **DC Breaker & DC Fuse**
Standard units are equipped with a fuse or a 2-pole circuit breaker. For units equipped with a fuse, an optional breaker is available. Refer to the model chart on the next page for further details.
- **AC Breaker**
Single Phase Units:
A two-pole breaker opens both legs of the AC service to 208VAC and 240VAC. Breaker opens phase side of 120VAC service.
Three Phase Units:
A three-pole breaker opens all three legs of the AC service.

REMOTE MONITORING

- Form "C" Alarm Contacts
- With optional Communications Card:
 - Connect to SCADA System
 - Web Monitoring
 - Alarm / Notification E-mails

ENCLOSURES

- **Dimensions**
Overall dimensions and weights are subject to change due to innovative product development and design. When space requirements are critical, please consult the factory.
- **Mounting**
Our enclosures are very versatile. Some units can be wall, floor or rack mounted and others can be wall or floor mounted. See the Case Specifications Chart on the last page of this data sheet for further details.

ENCLOSURES

- **Finish**
Pretreated with a seven stage iron phosphate wash, sealer and deionized rinse. Then coated with an environmentally safe and durable ANSI 61 gray Polyester TGIC Minitel powder finish.

ENVIRONMENTAL

- **Operating Temperature**
0 to 50°C
- **Storage Temperature**
-40 to 85°C
- **Humidity**
0 to 95% Relative Humidity (Non-Condensing)
- **Cooling**
Convection cooled

Optional Accessories

- 550 Digital Controller with LCD Display
- 551 Digital Controller with VFD Display
- 017 DC Breaker 2-Pole (Standard on some units) see chart on pg. 3 for further details.
- 01C 2-Pole High Interrupting Capacity AC Breaker 65KAIC 240 VAC. Only available for units with current draws above 8 amps.
- 01D 2-Pole High Interrupting Capacity AC Breaker 65KAIC 480 VAC. Only available for units with current draws above 8 amps.
- 01G 3-Pole High Interrupting Capacity AC Breaker 65KAIC 480 VAC. Only available for units with current draws above 8 amps.
- 05C DC Current Transducer
- 206 DC Voltage Transducer
- 102 Blocking Diode
- 11W External Temperature Probe 22ft
- 11Y External Temperature Probe 100ft
- 11L Lightning Arrestor
- 09C I.D. Tags - White text on black background
- 09V I.D. Tags - Black text on white background
- 09W Heat Shrink Wire Markers with Electrical Schematic
- 38G ABS Type Approval
- 07V 4C Case (Pending UL Listing)
- 537 OSHPD Certification Label (consult factory for Anchor Kits)
- 538 IBC Certification Label (consult factory for Anchor Kits)

Communication Protocols

- 21J IEC 61850
- 21P DNP 3.0 Communications RS232/RS485/Ethernet
- 21Q Modbus Communications RS232/RS485/Ethernet
- 21S Modbus RTU - Serial Data Port
- 21X SNMP



Standard LED Display

TABLE OF CONTENTS

TPSD Charger Chart

1-Phase																				
Model Number	DC Amps	DC Protection		60Hz									50Hz ⁽³⁾				Heat Loss ⁽⁴⁾ BTU's/ Hour	Case No.		
				AC Current Draw ⁽¹⁾ Recommended Feeder AC Supply Breaker									Shipping Weight		AC Current Draw ⁽¹⁾ Feeder AC Supply Breaker				Shipping Weight	
				DC Fuse	DC Breaker/ Rating	A1 120	ABD1 120/240/208	BLD1 240/220/208	Feeder** Breaker Size	Rating	C1 480V	Feeder** Breaker Size	Rating	lbs	kgs	5BL1 240/220			Feeder** Breaker Size	lbs
24V ⁽²⁾ (12L or 20NC)	TPSD-6-24V	6	---	10 / 7.5KAIC	2	---	---	5	2KAIC	---	---	---	90	40.8	---	---	---	---	119	4B***
	TPSD-12-24V	12	---	15 / 7.5KAIC	4	---	---	10	2KAIC	---	---	---	90	40.8	---	---	---	---	238	4B***
	TPSD-20-24V	20	---	30 / 7.5KAIC	---	6.7 / 3.4 / 3.9	---	10 / 5 / 5	5KAIC	---	---	---	100	45.4	3.4 / 3.7	5 / 5	110	49.8	396	4
	TPSD-25-24V	25	---	40 / 7.5KAIC	---	8.4 / 4.2 / 4.9	---	15 / 10 / 10	5KAIC	---	---	---	125	56.7	4.2 / 4.6	10 / 10	138	62.6	495	4
	TPSD-30-24V	30	---	40 / 7.5KAIC	---	11 / 5 / 5.8	---	15 / 10 / 10	5KAIC	---	---	---	150	68.0	5.0 / 5.5	10 / 10	165	74.8	405	4
	TPSD-35-24V	35	---	50 / 7.5KAIC	---	12 / 5.9 / 6.8	---	20 / 10 / 10	5KAIC	---	---	---	154	69.9	5.9 / 6.4	10 / 10	170	77.1	472	4
	TPSD-50-24V	50	---	70 / 7.5KAIC	---	17 / 8.4 / 9.7	---	30 / 15 / 15	5KAIC	---	---	---	175	79.4	8.4 / 9.2	15 / 15	193	87.5	674	4
	TPSD-75-24V	75	---	100 / 7.5KAIC	---	26 / 13 / 15	---	40 / 20 / 20	5KAIC	6.3	10	5KAIC	211	95.7	13 / 14	20 / 20	233	105.7	1011	4
TPSD-100-24V	100	130	Optional*	---	34 / 17 / 20	---	40 / 20 / 20	5KAIC	8.4	15	5KAIC	225	102.1	17 / 19	25 / 25	248	112.5	1347	9	
48V ⁽²⁾ (24L or 37NC)	TPSD-6-48V	6	---	10 / 7.5KAIC	4	---	---	10	2KAIC	---	---	---	90	40.8	---	---	---	---	191	4B***
	TPSD-12-48V	12	---	15 / 7.5KAIC	8.1	---	---	15	2KAIC	---	---	---	110	49.9	---	---	---	---	382	4B***
	TPSD-20-48V	20	---	30 / 7.5KAIC	---	14 / 6.7 / 7.8	---	20 / 10 / 10	5KAIC	---	---	---	150	68.0	6.7 / 7.3	10 / 10	165	74.8	637	4
	TPSD-25-48V	25	---	40 / 7.5KAIC	---	17 / 8.4 / 9.7	---	30 / 15 / 15	5KAIC	---	---	---	150	68.0	8.4 / 9.2	15 / 15	165	74.8	796	4
	TPSD-30-48V	30	---	40 / 7.5KAIC	---	21 / 11 / 12	---	30 / 15 / 15	5KAIC	---	---	---	155	70.3	11 / 11	15 / 15	171	77.6	601	4
	TPSD-35-48V	35	---	50 / 7.5KAIC	---	24 / 12 / 14	---	40 / 20 / 20	5KAIC	5.9	10	5KAIC	180	81.7	12 / 13	20 / 20	198	89.8	702	4
	TPSD-50-48V	50	---	70 / 7.5KAIC	---	34 / 17 / 20	---	40 / 20 / 20	5KAIC	8.4	15	5KAIC	205	93.0	17 / 19	25 / 25	225	102.1	1002	4
	TPSD-75-48V	75	---	100 / 7.5KAIC	---	51 / 26 / 30	---	70 / 35 / 35	5KAIC	13	20	5KAIC	295	133.8	26 / 28	40 / 40	325	147.4	1503	9
TPSD-100-48V	100	130	Optional*	---	---	34 / 37 / 39	50 / 50 / 50	5KAIC	17	25	5KAIC	321	145.6	34 / 37	50 / 50	354	160.6	2004	9	
130V ⁽²⁾ (58L or 60L 92NC or 96NC)	TPSD-6-130V	6	---	10 / 5KAIC	---	11 / 5 / 5.8	---	20 / 10 / 10	5KAIC	---	---	---	140	63.5	5.0 / 5.5	10 / 10	154	69.9	478	4
	TPSD-12-130V	12	---	15 / 10KAIC	---	21 / 11 / 12	---	30 / 15 / 15	5KAIC	---	---	---	175	79.4	11 / 11	15 / 15	193	87.5	955	4
	TPSD-20-130V	20	---	30 / 10KAIC	---	34 / 17 / 20	---	50 / 25 / 25	5KAIC	8.4	15	5KAIC	225	102.1	17 / 19	25 / 25	233	105.7	1591	4
	TPSD-25-130V	25	---	40 / 10KAIC	---	42 / 21 / 25	---	60 / 30 / 30	5KAIC	11	15	5KAIC	250	113.4	21 / 23	30 / 30	275	124.7	1989	4
	TPSD-30-130V	30	---	40 / 10KAIC	---	51 / 26 / 30	---	60 / 30 / 30	5KAIC	13	15	5KAIC	319	144.7	26 / 28	40 / 40	352	159.7	1503	9
	TPSD-35-130V	35	---	50 / 10KAIC	---	59 / 30 / 34	---	80 / 40 / 40	5KAIC	15	20	5KAIC	372	168.7	30 / 33	45 / 45	410	186	1753	9
	TPSD-50-130V	50	---	70 / 10KAIC	---	---	42 / 46 / 49	60 / 60 / 70	5KAIC	21	25	5KAIC	532	241.3	42 / 46	60 / 60	586	265.8	2504	9

* Optional DC Breaker is rated at 10KAIC.
 ** Recommended Breaker Size
 *** Also available in 4C case

3-Phase																				
Model Number	DC Amps	DC Protection		60Hz									50Hz ⁽³⁾				Heat Loss ⁽⁴⁾ BTU's/ Hour	Case No.		
				AC Current Draw ⁽¹⁾ Recommended Feeder AC Supply Breaker									Shipping Weight		AC Current Draw ⁽¹⁾ Feeder AC Supply Breaker				Shipping Weight	
				DC Fuse	DC Breaker/ Rating	BD3 240/208V	Feeder** Breaker Size	Rating	C3 480	Feeder** Breaker Size	Rating	lbs	kgs	5G3 380V	Feeder** Breaker Size	lbs			kgs	
24V ⁽²⁾ (12L or 20NC)	TPSD-75-24V	75	---	100 / 7.5KAIC	6.3 / 7.3	10 / 10	5KAIC	---	---	---	400	181.4	---	---	---	---	752	72		
	TPSD-100-24V	100	130	Optional*	8.5 / 9.8	15 / 15	5KAIC	---	---	---	475	215.5	---	---	---	---	1002	72		
	TPSD-150-24V	150	200	Optional*	13 / 15	20 / 20	5KAIC	6.3	15	5KAIC	530	240.4	---	---	---	---	1503	72		
	TPSD-200-24V	200	250	Optional*	17 / 20	25 / 25	5KAIC	8.5	15	5KAIC	600	272.2	---	---	---	---	2004	72		
48V ⁽²⁾ (24L or 37NC)	TPSD-50-48V	50	---	70 / 7.5KAIC	8.5 / 9.8	15 / 15	5KAIC	---	---	---	400	181.4	---	---	---	---	1002	72		
	TPSD-75-48V	75	---	100 / 7.5KAIC	13 / 15	25 / 25	5KAIC	6.3	10	5KAIC	575	260.8	---	---	---	---	1503	72		
	TPSD-100-48V	100	130	Optional*	17 / 20	30 / 30	5KAIC	8.5	15	5KAIC	600	272.2	---	---	---	---	2004	72		
	TPSD-150-48V	150	200	Optional*	26 / 30	40 / 40	5KAIC	13	20	5KAIC	700	317.5	---	---	---	---	3005	72		
TPSD-200-48V	200	250	Optional*	34 / 40	60 / 60	5KAIC	17	25	5KAIC	755	342.5	---	---	---	---	4007	72			
130V ⁽²⁾ (58L or 60L 92NC or 96NC)	TPSD-25-130V	25	---	40 / 10KAIC	11 / 13	20 / 20	5KAIC	---	---	---	420	190.5	---	---	---	---	1252	72		
	TPSD-30-130V	30	---	40 / 10KAIC	13 / 15	20 / 20	5KAIC	6.3	10	5KAIC	490	222.3	---	---	---	---	1503	72		
	TPSD-35-130V	35	---	50 / 10KAIC	15 / 18	25 / 25	5KAIC	7.4	10	5KAIC	550	249.5	---	---	---	---	1753	72		
	TPSD-50-130V	50	---	70 / 10KAIC	22 / 25	35 / 35	5KAIC	11	20	5KAIC	600	272.2	---	---	---	---	2504	72		
	TPSD-75-130V	75	100	Optional*	32 / 37	50 / 50	5KAIC	16	25	5KAIC	660	299.4	20	30	727	329.8	3756	72		
	TPSD-100-130V	100	130	Optional*	43 / 49	70 / 70	5KAIC	22	30	5KAIC	800	362.9	27	35	882	400.1	5008	72		
	TPSD-125-130V ⁽³⁾	125	200	Optional*	53 ⁽³⁾ / 61 ⁽³⁾	80 / 80	5KAIC	27 ⁽³⁾	40	5KAIC	850	385.6	---	---	---	---	6260	44		
TPSD-150-130V ⁽³⁾	150	200	Optional*	64 ⁽³⁾ / 74 ⁽³⁾	100 / 100	5KAIC	32 ⁽³⁾	45	5KAIC	900	408.2	---	---	---	---	7512	44			

* Optional DC Breaker is rated at 10KAIC.
 ** Recommended Breaker Size

⁽¹⁾ AC Current Draws based @ 100% load and standard battery cells of 12L (24V), 24L (48V) and 60L (130V). Maximum Current Draw is 115% of ratings shown.
⁽²⁾ Must specify only one battery type and number of cells from range shown above. Please consult factory for other available cell ranges if desired range not shown.
⁽³⁾ Not UL Listed
⁽⁴⁾ BTU's are based on 12L (24V), 24L (48V) and 60L (130V). Heat loss is stated for nominal float voltage, 100% output current and nominal AC line.

Case Specifications

Case No.	Overall Dimensions					
	Width		Depth		Height	
	in	mm	in	mm	in	mm
4B*	19.000	483	15.000	381	12.250*	311*
4C*	15.000	381	11.000	280	24.000*	610*
4*	19.000	483	15.000	381	24.000*	610*
9*	23.000	584	15.000	381	36.000*	914*
72	27.000	686	23.500	597	44.500	1130
44	24.000	610	19.000	483	72.100	1831

Case No.	Cable Entry (when facing unit)		Mounting
	AC input	DC output	
4B*	RIGHT TOP / BOTTOM / SIDE	LEFT TOP / BOTTOM	19/23" RACK, WALL/ FLOOR
4C*	RIGHT TOP / BOTTOM	LEFT TOP / BOTTOM / SIDE	WALL/ FLOOR
4*	RIGHT TOP/ BOTTOM	LEFT TOP / BOTTOM / SIDE	19/23" RACK, WALL / FLOOR
9*	RIGHT TOP / BOTTOM / SIDE	TOP / BOTTOM	23" RACK, WALL / FLOOR
72	RIGHT / BOTTOM / SIDE	BOTTOM	FLOOR
44	TOP LEFT	TOP RIGHT	FLOOR

*Floor mounting brackets add 2" (51mm) to overall height. Case sizes may differ depending on optional accessories. Consult factory when dimensions are critical. Detailed dimensional drawings are available for mounting purposes.

Adjustable DC Output Voltage Range

	Battery Cell Type Code	Float		Equalize	
		Min	Max	Min	Max
24V	12L	25.44	27.60	27.00	28.80
	20N	27.80	29.00	30.00	32.00
48V	24L	50.88	55.20	54.00	57.60
	37N	51.43	53.65	55.50	59.20
130V	58L	122.96	133.40	130.50	139.20
	60L	127.20	138.00	135.00	144.00
	92N	127.88	133.40	138.00	147.20
	96N	133.44	139.20	144.00	153.60

Battery Charger Sizing Guidelines

- Required Battery Backup Time (Hours)
- DC Output Voltage
- Ampere Hour Capacity of Battery
- Allowable Recharge Time From Full Discharge (Hours), Where Applicable
- Continuous and Intermittent DC Loads and Duration (Amps)

Model Number Nomenclature

TPSD - 25 - 130V - () () () - () - ()

Model Number: TPSD
 DC Amps: 25
 DC Volts: 130V
 Factory Assigned Accessory Code: ()
 Battery Cell Range: ()
 AC Phase Code: ()
 AC Voltage(s) Code(s): ()
 Special Frequency When Required: ()

**Special Frequency Code	AC Voltage Codes	AC Phase Codes	Battery Cell Type Code
5 - 50Hz	A - 120	1 - Single Phase	12L 20N 12LR
60Hz standard unless special code is entered	C - 480	3 - Three Phase	24L 37N 24LR
	G - 380		58L 92N 58LR
	BD - 240/208		60L 96N 60LR
	BL - 240/220		
	ABD - 120/240/208		L = Lead Acid
	BLD - 240/220/208		N = Nickel Cadmium
			LR = VRLA

Ordering Information

When ordering, please specify:

- La Marche Model Number TPSD
- DC Amps
- DC Volts
- Special Frequency, When Required
- AC Voltage Code
- AC Phase Code
- Battery Cell Type Code
- Optional Accessories (Option Code)



Unit Shown: A77DE



Microprocessor Controlled SCR Battery Charger

The La Marche Model A77 Series Battery Charger is engineered for the demanding requirements of Switchgear, Process Control, Oil Exploration and other DC power applications.

Powered by Microprocessor Controlled SCR technology, the A77 Series Battery Charger / Battery Eliminator has $\pm 0.25\%$ DC voltage regulation from no load to full load over the specified input voltage, frequency and ambient temperature ranges.

These chargers are available in DC output voltages of 24, 48, 130, and 260 VDC with DC output currents from 6 amps and above. Consult factory for any special input and output requirements not mentioned above.

The La Marche A77 charger provides value added features such as AC/DC breakers, easy to read LCD display with text readout alarm LED's and form "C" alarm contacts. Communication options are available to remotely monitor and control the charger using DNP3, Modbus, IEC 61850 and SNMP protocols. The SNMP option features easier and faster charger setup and configuration using a web browser.

Designed to meet NEMA PE5 and UL 1012 safety standards.

Standard Features

- Microprocessor Controlled SCR Technology
- A77D - Filtered
- A77DE - Battery Eliminator
- Automatic AC Voltage Compensation
- AC & DC Surge Protection (MOV)
- AC & DC Breaker
- Temperature Compensation
Adjustable (1-5 mV / cell/°C)
- Float / Equalize Mode Switch
- Digital Float and Equalize Adjustments
- Digital Current Limit Adjustment 50 to 110%
- $\pm 0.25\%$ DC Voltage Regulation
- SCR Failure Detection
- Battery Continuity Test
- Load Sharing
- Remote Equalize
- Over Temperature Protection
- LCD Display
 - DC Voltage and Current
 - Alarms
 - Unit Temperatures
- Advanced Data Logging (Micro SD)
- LED Indicators
 - Float / Equalize
 - AC Failure
 - AC ON
 - Summary Alarm
 - Charger Failure
 - Low DC Current
 - Overload / Current Limit
 - Low DC Voltage
 - End of Discharge
 - High DC Voltage
 - High DC Voltage Shutdown
 - Positive & Negative Ground Detection
- Remote Annunciation Form "C" Contacts
 - AC Failure
 - Summary Alarm
 - (See Optional Accessories For Additional Alarm Contacts)
- Alarms Latching / Non-Latching
- Equalize Timer - adjustable from 1-255 hours with five selectable modes of operation (manual, automatic every 7, 14 or 30 days and equalize after sensing a low DC voltage)
- UL 1012, CUL, IBC & ABS
- 5 Year Warranty



Specifications

ELECTRICAL

- **AC Input Operating Range Voltage**
Voltage range: +10, -12% from nominal
Frequency range: 60 Hz \pm 5%
(50Hz Consult Factory)
- **Single Phase Voltages:**
120, 208, 240, 480 or 600 VAC
(Tap selectable 120/208/240 on units up to 25 amp output. All other units must specify single input voltage). Consult factory for other voltages.
- **Three Phase Voltages:**
208, 240, 480 or 600 VAC
Consult factory for other voltages.
- **DC Output**
24, 48, 130, 260 VDC
6 to 500 amps
- **Efficiency***
Single Phase > 85%
Three Phase > 90%
* Based on 130Vdc output units
- **Output Filtering (with or without batteries):**

	24V	48V	130V	260V
A77D Filtered (w/o battery)	240mV (1%)	480mV (1%)	2.6V (2%)	5.2V (2%)
A77D Filtered (w/battery)	30mV	30mV	100mV*	200mV*
A77DE Eliminator (w/o battery)	30mV	30mV	100mV**	200mV

* Battery AH = 4x the charger's ampacity
** 30mV filtering available as an option

- **DC Voltage Regulation Steady State**
 \pm 0.25% of setting from no load to full load over the specified input voltage, frequency and ambient temperature ranges.

DC Output Voltage Range

	Volt		Cells	
	Float	Equalize	Lead Acid	Ni-Cad
24V	23.8-29.5	24-31	11-13L	17-20N
48V	46-57	48-59	22-26L	33-39N
130V	115-140	123-147	53-62L	83-93N
260V	230-280	246-294	106-124L	166-186N

Consult Factory for other ratings.
Note: Typical cell ranges are based on the following:
Lead Acid 2.17 vpc Float, 2.33 vpc Equalize
NiCad 1.40 vpc Float, 1.55 vpc Equalize
VRLA 2.25 vpc Float, 2.27 vpc Equalize

Front Display Panel



- **Data Logging**
A77 Battery Charger is equipped with data logging capability on an internal Micro-SD Card. It logs and stores data of Event-Driven and Time-Interval-Driven Events. The charger's data-log file does not need proprietary software to examine the data; it could be viewed and easily formatted with many popular spreadsheet programs.
- **Dynamic Response (On Battery)**
Voltage transient \leq \pm 5% over a step change in the load from 20% to 100%
Recovery Time $<$ 200 ms
- **Audible Noise**
Less than 65dBA at any point 5 feet from any vertical surface of the unit.
- **Load Sharing**
Identical La Marche A77 units, when connected in parallel, are capable of sharing the DC load within \pm 5% for individual unit outputs greater than 5% of the rated output.

REMOTE MONITORING

- Form "C" Alarm Contacts
- With optional Communications Card:
 - Connect to SCADA System
 - Web Monitoring
 - Alarm / Notification E-mails

PROTECTION

- **Current Walk-in**
The output current will gradually increase after the charger is turned on, eliminating surges and overshoot.
- **Current Limit**
Electronic Current-Limiting Control Circuitry provides a digitally adjustable limit from 50 to 110% of the rated output current of the charger, Factory set at 110%.
- **AC Breaker**
Single Phase units are equipped with a 2-pole circuit breaker.
Three Phase units are equipped with a 3-pole circuit breaker.
- **DC Breaker**
Standard units are equipped with a 2-pole circuit breaker.

ENVIRONMENTAL

- **Operating Temperature**
0 to 50°C (32 to 122°F)
- **Storage Temperature**
-40 to 85°C (-40 to 185°F)
- **Relative Humidity**
0 to 95% (non-condensing)
- **Cooling**
Convection Cooled

ENCLOSURES

- **NEMA Type 1**
Consult factory for other enclosure ratings.
- **Dimensions**
Overall dimensions and weight are listed on the last page. When space requirements are critical, please consult the factory. Case specifications are subject to change.
- **Mounting**
Floor, wall or rack mounting is available; see enclosure specifications on page 4 for details.
- **Finish**
Pretreated with a seven stage iron phosphate wash, sealer and deionized rinse. Then coated with an environmentally safe and durable ANSI 61 gray Polyester TGIC Minite powder finish.

STANDARDS

- ABS*
- UL/CUL 1012
- EN 55011
- NEMA PE5
- FCC Part 15
- IEEE / ANSI C37. 90.1
- IEC 60255-22-3
- IEC 60950-1
- IEC 61000-4
- IEC 61000-6-4
- IEC 61000-6-2
- IBC*

* Requires an option code

Optional Accessories

- 01C 2 - Pole High Interrupting Capacity AC Breaker \dagger
65KAIC @ 240 VAC / 35KAIC @ 480 VAC
 - 01D 2 - Pole High Interrupting Capacity AC Breaker \dagger
100KAIC @ 240 VAC / 65KAIC @ 480 VAC / 25KAIC @ 600 VAC
 - 01F 3 - Pole High Interrupting Capacity AC Breaker \dagger
65KAIC @ 240 VAC / 35KAIC @ 480 VAC
 - 01G 3 - Pole High Interrupting Capacity AC Breaker \dagger
100KAIC @ 240 VAC / 65KAIC @ 480 VAC / 25KAIC @ 600 VAC
- \dagger Only available for units with current draws above 8 amps
- 19T AC Breaker Trip on HVSD
 - 19U Adjustable Ground Detection Sensitivity
 - 19V AC Voltage & Current Metering (1%)
 - 11F Special 30mV Filtering
 - 20Q Equalize Fan Control Relay
 - 217 Reverse Polarity Protection & LED
 - 38D Copper Ground Bus Bar
 - 11L Lightning Arrestor
 - 102 Blocking Diode
 - 11W External Temperature Probe 24ft
 - 11Y External Temperature Probe 100ft
 - 09C I.D. Tags - White text on black background
 - 09V I.D. Tags - Black text on white background
 - 09W Heat Shrink Wire Markers with Electrical Schematic
 - 46R Discrete Alarm Relays
 - Positive Ground
 - Negative Ground
 - High DC Volts
 - Charger Failure
 - Low DC Volts
 - Low DC Amps
 - Battery End of Discharge
 - High Voltage Shutdown
 - 17B* 12 Pulse Rectification, 5% THD
 - 06G Zero Center Ammeter
 - 57D Hydrogen Det. HUB, Alarm Interface & Sensor
 - 57H Hydrogen Det. HUB, Alarm Interface
 - 10Z Electrolyte Level HUB, Alarm Interface & Sensor
 - 538 IBC Certification Label (consult factory for Anchor Kits)
 - 182 Ventilation Fan Interlock
 - 56E Compliance to IEC 62477-1:2012 and IEC 61204-7:2016

Communication Protocols

- 21J IEC 61850 Ethernet
- 21P DNP 3.0 Communications RS232/RS485/Ethernet
- 21Q Modbus Communications RS232/RS485/Ethernet
- 21S Modbus RTU RS232/RS485
- 21X SNMP & Web Browser (Ethernet)

* Case size subject to change, consult factory.

A77 Charger Chart

TABLE OF CONTENTS

	Model Number	DC Amps	DC Protection DC Breaker/ Rating	Single Phase AC Input Current Draw Amps @ 100% Load (Recommended Feeder AC Supply Breaker)									Enclosure	Shipping Weight** (Approximate)	
				(ABD)120/240/208	(A)120	(D)208	(B)240	Rating	(C)480	Rating	(ZD)600	Rating		lbs	kgs
24 Volt Systems	A77D(E)-6-24V	6	15/10 KAIC	3 / 2 / 2 (5/5/5)	---	---	---	10 KAIC	---	---	---	---	10	71	32
	A77D(E)-12-24V	12	20/10 KAIC	6 / 3 / 3 (10/5/5)	---	---	---	10 KAIC	---	---	---	---	10	92	42
	A77D(E)-16-24V	16	25/10 KAIC	8 / 4 / 5 (15/10/10)	---	---	---	10 KAIC	---	---	---	---	10	98	45
	A77D(E)-20-24V	20	30/10 KAIC	10 / 5 / 6 (15/10/10)	---	---	---	10 KAIC	---	---	---	---	10	100	46
	A77D(E)-25-24V	25	40/10 KAIC	12 / 6 / 7 (20/10/10)	---	---	---	10 KAIC	---	---	---	---	10	104	48
	A77D(E)-30-24V	30	40/10 KAIC	---	15 (20)	8 (15)	7 (15)	25 KAIC	4 (10)	14 KAIC	---	---	477	147	67
	A77D(E)-35-24V	35	50/10 KAIC	---	17 (25)	10 (15)	9 (15)	25 KAIC	4 (10)	14 KAIC	---	---	477	150	69
	A77D(E)-40-24V	40	60/10 KAIC	---	20 (30)	11 (20)	10 (15)	25 KAIC	5 (10)	14 KAIC	4 (10)	18 KAIC	477	174	79
	A77D(E)-50-24V	50	70/10 KAIC	---	24 (40)	14 (20)	12 (20)	25 KAIC	6 (10)	14 KAIC	5 (10)	18 KAIC	477	185	84
	A77D(E)-60-24V	60	80/10 KAIC	---	29 (40)	17 (25)	15 (20)	25 KAIC	7 (10)	14 KAIC	6 (10)	18 KAIC	477	208	95
A77D(E)-75-24V	75	100/10 KAIC	---	37 (50)	21 (30)	18 (30)	25 KAIC	9 (15)	14 KAIC	7 (10)	18 KAIC	977	350	159	
A77D(E)-100-24V	100	150/25 KAIC	---	49 (70)	28 (40)	24 (40)*	25 KAIC	12 (20)	22 KAIC	10 (15)	18 KAIC	977	385	175	
48 Volt Systems	A77D(E)-6-48V	6	15/10 KAIC	6 / 3 / 3 (10/5/5)	---	---	---	10 KAIC	---	---	---	---	10	84	38
	A77D(E)-12-48V	12	20/10 KAIC	12 / 6 / 7 (20/10/10)	---	---	---	10 KAIC	---	---	---	---	10	108	49
	A77D(E)-16-48V	16	25/10 KAIC	16 / 8 / 9 (25/15/15)	---	---	---	25 KAIC	---	---	---	---	477	146	66
	A77D(E)-20-48V	20	30/10 KAIC	20 / 10 / 11 (30/15/20)	---	---	---	25 KAIC	5 (10)	14 KAIC	---	---	477	158	72
	A77D(E)-25-48V	25	40/10 KAIC	24 / 12 / 14 (35/20/25)	---	---	---	25 KAIC	6 (10)	14 KAIC	5 (10)	18 KAIC	477	170	73
	A77D(E)-30-48V	30	40/10 KAIC	---	29 (40)	17 (25)	15 (20)	25 KAIC	7 (10)	14 KAIC	6 (10)	18 KAIC	477	190	86
	A77D(E)-35-48V	35	50/10 KAIC	---	34 (50)	20 (30)	17 (25)	25 KAIC	9 (15)	14 KAIC	7 (10)	18 KAIC	477	196	89
	A77D(E)-40-48V	40	60/10 KAIC	---	39 (60)	23 (40)*	20 (30)	25 KAIC	10 (15)	14 KAIC	8 (15)	18 KAIC	477	240	109
	A77D(E)-50-48V	50	70/10 KAIC	---	49 (70)	28 (40)	24 (40)*	25 KAIC	12 (20)	22 KAIC	10 (15)	18 KAIC	477	260	118
	A77D(E)-60-48V	60	80/10 KAIC	---	59 (90)	34 (50)	29 (40)	25 KAIC	15 (20)	22 KAIC	12 (20)	18 KAIC	977	300	137
A77D(E)-75-48V	75	100/10 KAIC	---	73 (100)	42 (60)	37 (50)	25 KAIC	18 (25)	22 KAIC	15 (20)	18 KAIC	977	350	159	
A77D(E)-100-48V	100	150/25 KAIC	---	98 (150)	56 (90)	49 (70)	25 KAIC	24 (40)*	22 KAIC	20 (30)	18 KAIC	977	460	209	
130 Volt Systems	A77D(E)-6-130V	6	15/10 KAIC	15 / 7 / 8 (25/10/15)	---	---	---	25 KAIC	4 (10)	14 KAIC	3 (5)	18 KAIC	477	147	67
	A77D(E)-12-130V	12	20/10 KAIC	29 / 15 / 17 (40/25/25)	---	---	---	25 KAIC	7 (10)	14 KAIC	6 (10)	18 KAIC	477	185	84
	A77D(E)-16-130V	16	25/10 KAIC	39 / 20 / 23 (60/30/40*)	---	---	---	25 KAIC	10 (15)	14 KAIC	8 (15)	18 KAIC	477	212	96
	A77D(E)-20-130V	20	30/10 KAIC	49 / 24 / 28 (70/35/40)	---	---	---	25 KAIC	12 (20)	22 KAIC	10 (15)	18 KAIC	477	235	107
	A77D(E)-25-130V	25	40/10 KAIC	61 / 31 / 35 (90/50/50)	---	---	---	25 KAIC	15 (20)	22 KAIC	12 (20)	18 KAIC	477	255	116
	A77D(E)-30-130V	30	40/10 KAIC	---	73 (100)	42 (60)	37 (50)	25 KAIC	18 (25)	22 KAIC	15 (20)	18 KAIC	477	300	137
	A77D(E)-35-130V	35	50/10 KAIC	---	85 (125)	49 (70)	43 (60)	25 KAIC	21 (30)	22 KAIC	17 (25)	18 KAIC	977	375	171
	A77D(E)-40-130V	40	60/10 KAIC	---	98 (150)	56 (80)	49 (70)	25 KAIC	24 (40)*	22 KAIC	20 (30)	18 KAIC	977	422	192
	A77D(E)-50-130V	50	70/10 KAIC	---	---	70 (100)	61 (90)	25 KAIC	31 (50)	22 KAIC	24 (40)*	18 KAIC	977	480	218
A77D(E)-75-130V	75	100/10 KAIC	---	---	106 (150)	92 (125)	25 KAIC	46 (70)	22 KAIC	37 (50)	18 KAIC	72N	735	334	

	Model Number	DC Amps	DC Protection DC Breaker/ Rating	Three Phase AC Input Current Draw Amps @ 100% Load (Recommended Feeder AC Supply Breaker)						Enclosure	Shipping Weight** (Approximate)		
				(D) 208	(B) 240	Rating	(C) 480	Rating	(ZD) 600		Rating	lbs	kgs
24 Volt Systems	A77D(E)-75-24V	75	100/10 KAIC	11 (15)	9 (15)	25 KAIC	5 (10)	14 KAIC	4 (5)	18 KAIC	977	330	150
	A77D(E)-100-24V	100	150/25 KAIC	14 (20)	12 (20)	25 KAIC	6 (10)	14 KAIC	5 (10)	18 KAIC	977	475	215
	A77D(E)-125-24V	125	175/25 KAIC	18 (25)	16 (25)	25 KAIC	8 (15)	14 KAIC	6 (10)	18 KAIC	72N	530	240
	A77D(E)-150-24V	150	225/25 KAIC	22 (30)	19 (30)	25 KAIC	9 (15)	14 KAIC	7 (15)	18 KAIC	72N	600	272
	A77D(E)-200-24V	200	300/25 KAIC	29 (40)	25 (40)*	25 KAIC	12 (20)	22 KAIC	10 (15)	18 KAIC	72N	675	306
	A77D(E)-250-24V	250	375/25 KAIC	36 (50)	31 (50)	25 KAIC	16 (25)	22 KAIC	12 (20)	18 KAIC	46N	800	363
	A77D(E)-300-24V	300	400/25 KAIC	43 (60)	37 (60)	25 KAIC	19 (30)	22 KAIC	15 (25)	18 KAIC	46N	875	398
	A77D(E)-400-24V	400	600/35 KAIC	58 (80)	50 (70)	25 KAIC	25 (40)*	22 KAIC	20 (30)	18 KAIC	47N	1050	477
48 Volt Systems	A77D(E)-50-48V	50	70/10 KAIC	14 (20)	12 (20)	25 KAIC	6 (10)	14 KAIC	5 (10)	18 KAIC	977	317	144
	A77D(E)-75-48V	75	100/10 KAIC	22 (30)	19 (30)	25 KAIC	9 (15)	14 KAIC	7 (15)	18 KAIC	977	374	170
	A77D(E)-100-48V	100	150/25 KAIC	29 (40)	25 (40)*	25 KAIC	12 (20)	22 KAIC	10 (15)	18 KAIC	977	600	272
	A77D(E)-125-48V	125	175/25 KAIC	36 (50)	31 (50)	25 KAIC	16 (25)	22 KAIC	12 (20)	18 KAIC	72N	680	308
	A77D(E)-150-48V	150	225/25 KAIC	43 (60)	37 (60)	25 KAIC	19 (30)	22 KAIC	15 (25)	18 KAIC	72N	700	318
	A77D(E)-200-48V	200	300/25 KAIC	58 (80)	50 (70)	25 KAIC	25 (40)*	22 KAIC	20 (30)	18 KAIC	46N	755	342
	A77D(E)-250-48V	250	375/25 KAIC	72 (100)	62 (90)	25 KAIC	31 (50)	22 KAIC	25 (40)*	18 KAIC	46N	800	363
	A77D(E)-300-48V	300	400/25 KAIC	86 (125)	75 (100)	25 KAIC	37 (60)	22 KAIC	30 (50)	18 KAIC	47N	900	408
A77D(E)-400-48V	400	600/35 KAIC	115 (175)	100 (150)	25 KAIC	50 (70)	22 KAIC	40 (60)	18 KAIC	47N	1200	544	
130 Volt Systems	A77D(E)-25-130V	25	40/10 KAIC	18 (30)	16 (25)	25 KAIC	8 (15)	14 KAIC	6 (10)	18 KAIC	977	305	138
	A77D(E)-30-130V	30	40/10 KAIC	22 (30)	19 (30)	25 KAIC	9 (15)	14 KAIC	7 (15)	18 KAIC	977	315	143
	A77D(E)-35-130V	35	50/10 KAIC	25 (40)*	22 (30)	25 KAIC	11 (15)	14 KAIC	9 (15)	18 KAIC	977	330	150
	A77D(E)-40-130V	40	60/10 KAIC	29 (40)	25 (40)*	25 KAIC	12 (20)	22 KAIC	10 (15)	18 KAIC	977	335	161
	A77D(E)-50-130V	50	70/10 KAIC	36 (50)	31 (50)	25 KAIC	16 (25)	22 KAIC	12 (20)	18 KAIC	977	410	186
	A77D(E)-75-130V	75	100/10 KAIC	54 (80)	47 (70)	25 KAIC	23 (40)*	22 KAIC	19 (30)	18 KAIC	72N	660	299
	A77D(E)-100-130V	100	150/25 KAIC	72 (100)	62 (90)	25 KAIC	31 (50)	22 KAIC	25 (40)*	18 KAIC	72N	750	340
	A77D(E)-125-130V	125	175/25 KAIC	90 (125)	78 (125)	25 KAIC	39 (60)	22 KAIC	31 (50)	18 KAIC	46N	850	385
	A77D(E)-150-130V	150	225/25 KAIC	108 (150)	94 (125)	25 KAIC	47 (70)	22 KAIC	37 (60)	18 KAIC	46N	1067	484
	A77D(E)-200-130V	200	300/25 KAIC	144 (200)	125 (175)	25 KAIC	62 (90)	22 KAIC	50 (70)	18 KAIC	46N	1800	816
A77D(E)-250-130V	250	375/25 KAIC	180 (250)	156 (225)	25 KAIC	78 (125)	25 KAIC	62 (90)	18 KAIC	47N	2000	907	
A77D(E)-300-130V	300	400/25 KAIC	216 (300)	187 (300)	65 KAIC	94 (150)	25 KAIC	75 (100)	18 KAIC	47N	2028	920	
A77D(E)-400-130V	400	600/35 KAIC	288 (400)	250 (350)	65 KAIC	125 (175)	25 KAIC	100 (150)	18 KAIC	57N	2500	1134	
A77D(E)-500-130V†	500	700/35 KAIC	360 (500)	312 (450)	65 KAIC	156 (225)	25 KAIC	125 (175)	18 KAIC	57N	3645	1653	

Note: Case size subject to change without notice
 * May also use 35A feeder breaker
 **Consult Factory for optional export crating weight

TABLE OF CONTENTS

A77 Charger Chart

	Model Number	DC Amps	DC Protection DC Breaker/ Rating	Three Phase AC Input Current Draw Amps @ 100% Load (Recommended Feeder AC Supply Breaker)						Enclosure	Shipping Weight** (Approximate)		
				(D)208	(B)240	Rating	(C)480	Rating	(ZD)600		Rating	lbs	kgs
				260 Volt Systems	A77D(E)-25-260V†	25	40/25 KAIC	36 (50)	31 (50)		25 KAIC	16 (25)	22 KAIC
A77D(E)-50-260V†	50	70/25 KAIC	72 (100)		62 (90)	25 KAIC	31 (50)	22 KAIC	26 (40)	18 KAIC	72N	700	317
A77D(E)-75-260V†	75	100/25 KAIC	108 (150)		94 (125)	25 KAIC	47 (70)	22 KAIC	39 (60)	18 KAIC	46N	900	408
A77D(E)-100-260V†	100	150/25 KAIC	144 (200)		125 (175)	25 KAIC	62 (90)	22 KAIC	50 (70)	18 KAIC	47N	1800	816
A77D(E)-150-260V†	150	225/25 KAIC	---		187 (250)	25 KAIC	94 (150)	25 KAIC	75 (100)	18 KAIC	47N	2200	998
A77D(E)-200-260V†	200	300/25 KAIC	---	---	25 KAIC	125 (175)	25 KAIC	100 (150)	18 KAIC	57N	3000	1360	

Note: Case size subject to change without notice
 **Consult Factory for optional export crating weight
 † UL Pending

Enclosure Specifications

Enclosure	Overall Dimensions						Cable Entry		Standard Mounting	Optional Mounting Kits	
	Width		Depth		Height		AC Input	DC Input		Rack	Floor
	in	mm	in	mm	in	mm					
10	19	483	15.1	384	12.2	310	RIGHT TOP / BOTTOM	LEFT TOP / BOTTOM	WALL	19" / 23"	✓
477	19	483	15.6	396	23.6	602	RIGHT TOP / BOTTOM	LEFT TOP / BOTTOM	WALL	19" / 23"	✓
977	20.5	521	15.8	403	37.8	962	RIGHT TOP / BOTTOM	LEFT TOP / BOTTOM	FLOOR	23"	STD
72N	27	686	24.4	621	43.6	1109	BOTTOM RIGHT	BOTTOM LEFT	FLOOR	---	---
46N	30	762	20	508	66	1676	TOP / BOTTOM	TOP / BOTTOM	FLOOR	---	---
47N	35.4	899	33.4	848	67.5	1715	TOP / BOTTOM	TOP / BOTTOM	FLOOR	---	---
57N	60	1524	30	763	77	1962	TOP / BOTTOM	TOP / BOTTOM	FLOOR	---	---

Model Number Nomenclature

A77D (E) - 25 - 130V - () 1 - () - ()

Model Number: A77D (E)
 Battery Eliminator: -
 DC Amps: 25
 DC Volts: 130V
 Factory Assigned Accessory Code: ()
 Battery Cell Type Code: 1
 AC Phase Code: ()
 AC Voltage Code: ()

AC Voltage Codes ABD - 120/240/208 A - 120 D - 208 L - 220 Q - 230 BL - 240/220 B - 240 G - 380 ZA - 400 J - 415 K - 440 C - 480 ZD - 600	AC Phase Codes 1 - Single Phase 3 - Three Phase	Battery Cell Type Code 11L 12L 13L 22L 23L 24L 25L 26L 53L 54L 55L 56L 57L 58L 59L 60L 61L 62L 110L 115L 116L 120L 17N 18N 19N 20N 33N 34N 35N 36N 37N 38N 39N 83N 84N 85N 86N 87N 88N 89N 90N 91N 92N 93N I = Lead Acid N = Nickel Cadmium LR = VRLA
---	--	---

Ordering Information

- When ordering, please specify:**
- La Marche Model Number A77D/A77DE
 - DC Amps
 - DC Volts
 - Special Frequency, When Required
 - AC Voltage Code
 - AC Phase Code
 - Battery Cell Type Code
 - Optional Accessories (Option Code)

Battery Charger Sizing Guidelines

- Required Battery Backup Time (Hours)
- DC Output Voltage
- Ampere Hour Capacity of Battery
- Allowable Recharge Time From Full Discharge (Hours), Where Applicable
- Continuous and Intermittent DC Loads and Duration (Amps)



Microprocessor Controlled SCR Battery Charger



Unit Shown: ESCR125-16-125V-ABD1

The La Marche ESCR125 Model is designed specifically to provide an economical and robust solution for Auxiliary DC Control Power Systems in Substations. This Smart Microprocessor controlled Battery Charger is designed with PWM controls to provide the highest reliability that is required for maintaining and recharging the batteries, along with supporting the continuous loads in the auxiliary DC system.

The La Marche ESCR125 is designed per NEMA PE5, C62.41A and UL safety requirements. This Filtered Battery Charger meets NEMA PE5 filtering requirements and has 0.5% DC voltage regulation from no load to full load (over the specified input voltage, frequency and ambient temperature ranges). Those features along with its Temperature Compensation capability make this model suitable for various types of batteries such as flooded lead acid, VRLA and NiCad.

ESCR125 is equipped with a two-line LCD which displays output voltage and current, along with an alarm status text description. Individual LED indicators provide local supervision, Form "C" Alarm Contacts and Communication Protocols are available for remote annunciation.

Standard Features

- Smart Microprocessor Controlled SCR Technology
- Filtered Battery Charger
- Automatic AC Voltage Compensation
- AC & DC Surge Protection (MOV)
- AC & DC Breaker
- Temperature Compensation
- Float/Equalize Mode Switch
- Digital Float and Equalize Adjustments
- Digital Current Limit Adjustment 50 to 110%
- $\pm 0.5\%$ DC Voltage Regulation
- Over Temperature Protection
- LCD Display
- Soft Start
- Meets NEMA PE5 and C62.41A
- UL/CUL 1012 (Pending)
- 2 Year Warranty

Optional Accessories

- 080** Drip Shield
- 09P** Conformal Coated Circuit Boards
- 11W** External Temperature Probe 24ft
- 11Y** External Temperature Probe 100ft
- 10R** AAR Hardware

TABLE OF CONTENTS

Model Number	DC Output			AC Input			Case No.	Overall Dimensions W x D x H	Shipping Weight	
	Volts (Nominal)	Amps	DC Breaker Rating	Volts (Nominal)	Current Draw	Feeder Breaker Size			lbs	kg
ESCR125-16-125V-ABD1	125	16	5kAIC	120/208/240	37/22/19	50/30/30	4E	15.3" x 11.0" x 23.7" 391 x 279 x 603mm	145	66
ESCR125-25-125V-ABD1	125	25	5kAIC	120/208/240	58/34/29	80/50/40	4E	19.0" x 15.0" x 24.0"* 483 x 381 x 610mm	159	72

*Floor mounting brackets add 2" (51mm) to overall height. Case sizes may differ depending on optional accessories. Consult factory when dimensions are critical. Detailed dimensional drawings are available for mounting purposes.

<p>AC INPUT</p> <ul style="list-style-type: none"> 120/208/240 VAC $\pm 10\%$, 50/60HZ, Single Phase <p>DC OUTPUT</p> <ul style="list-style-type: none"> 16A @ 125VDC 25A @ 125VDC <p>REGULATION</p> <ul style="list-style-type: none"> Line: $< \pm 0.5\%$ Load: $< \pm 0.5\%$ <p>OUTPUT FILTERING</p> <ul style="list-style-type: none"> Per NEMA PE5 Filtered Charger <p>PROTECTION</p> <ul style="list-style-type: none"> Input Breaker with Surge Protection Output Breaker with Surge Protection <p>BATTERY CELL SELECTION</p> <ul style="list-style-type: none"> 53L-62L 83NC-93NC <p>OUTPUT CURRENT LIMIT</p> <ul style="list-style-type: none"> Adjustable from 50 - 110% (Factory set at 105%) <p>ADJUSTABLE VOLTAGE RANGE</p> <ul style="list-style-type: none"> Float Voltage 2.12 - 2.35 volts/cell (Lead) 1.35 - 1.45 volts/cell (NiCad) Equalize Voltage 2.25 - 2.40 volts/cell (Lead) 1.45 - 1.6 volts/cell (NiCad) 	<p>METERING</p> <ul style="list-style-type: none"> LCD DC Output Digital Voltmeter and Ammeter (1%) <p>CONTROLS</p> <ul style="list-style-type: none"> Float and Equalize Button Switch from Float to Equalize Configure Button Output Settings Voltage and Cells Adjust Voltage for Float & Equalize Adjust Alarm Settings and Delay High Voltage Shutdown Enable/Disable Temperature Compensation Equalize Timer ~ Multi-Mode Equalize Timer and Light; adjustable from 1 - 145 hrs ~ Five selectable modes: Manual (Default Factory Setting), 7-day, 14-day, 30-day and Equalize after Low DC Voltage and/or AC Failure Battery Continuity Test Manual and Periodic Battery Test Lamp Test Tests LCD Display & LED's <p>ALARM CONTACTS</p> <ul style="list-style-type: none"> AC Failure Low DC Voltage High DC Voltage Charger Failure Alarm <p>Form "C" contact rated 2A @ 30VDC/0.5A @ 125VAC</p> <p>MONITORING</p> <ul style="list-style-type: none"> LCD Display Volts Amps Status 	<p>MONITORING</p> <ul style="list-style-type: none"> LED Indications Float (Green) Equalize (Yellow) AC ON (Green) Charger Failure (Red) Battery Fault (Red) Current Limit (Yellow) High DC Voltage (Red) Low DC Voltage (Red) Negative Ground Detection (Red) Positive Ground Detection (Red) <p>ENVIRONMENTAL</p> <ul style="list-style-type: none"> Operating -20° to 70°C (derated above 50°C) Storage -40° to 85° C Relative Humidity 5% to 95% non-condensing <p>ENCLOSURE</p> <ul style="list-style-type: none"> Structural Design Wall/Floor Mount NEMA 1 powder coated Cable Entry Both sides <p>STANDARDS</p> <ul style="list-style-type: none"> UL 1012 (pending) CUL (pending) NEMA PE5 C62.41A CE (pending)
---	---	---

Model Number Nomenclature

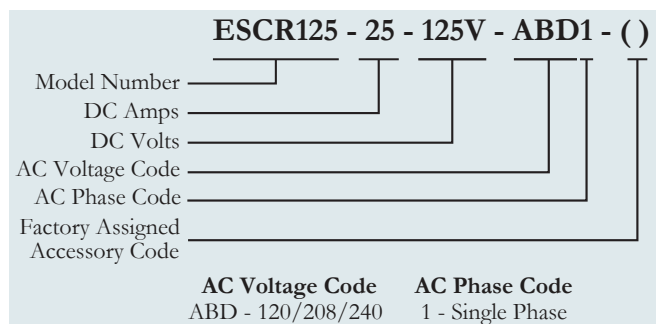

Front Panel Display

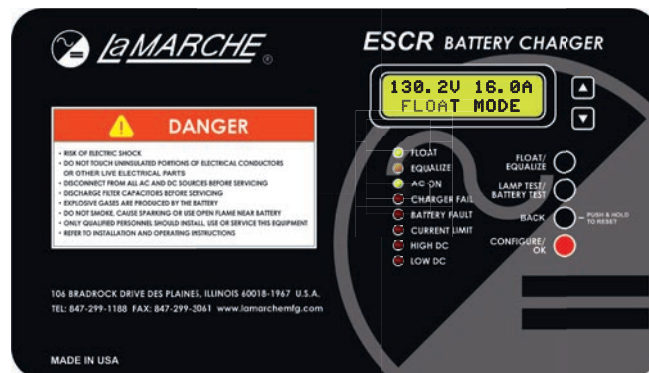



23" A96 Cage shown above with four A96 rectifiers

130VDC Switchmode Utility Rectifier

The La Marche A96 provides highly reliable, hot swappable 130VDC power with full load sharing capability in a compact, modular rectifier system. At a height of only 4RU in a four across 23" rack configuration it offers high power density. There is no need to shut down the system to change a rectifier. With current limiting circuitry, voltage regulation, high efficiency and high power factor, the A96 is the ultimate modular rectifier for Utility applications.

La Marche A96 systems provide highly filtered DC power which helps extend the life of the battery, and it can also be used as a power supply/battery eliminator. The loss of one rectifier will not affect the operation of the remaining rectifiers. Complete front panel accessibility and a hot plug-in design ensure quick, convenient, installation without the possibility of wiring errors.

Adverse power conditions do not affect the DC output. The AC input line regulation operates over a range of 188-264 volts, with a frequency range of 45-66 Hz. This allows it to be used with any 50/60 Hz, 208-240 volt service line, eliminating the need and expense of stocking different rectifiers for each input voltage. Steady state output voltage remains within $\pm 0.5\%$ of the setting from no load to full load to handle charging today's diverse battery technologies. A standard 23" Rack Mounted Power Cage can hold up to four 20 amp rectifiers which will provide a total of 80 amps of power.

Standard Features

Rectifier

- Single Phase AC Input
- 130 Volts DC, 20 Amps Per Rectifier
- 90% Efficiency
- Compact, Modular System
- Power Supply/Battery Eliminator
- Hot Plug-In Design
- Power Factor Correction Circuitry
- Selective High Voltage Shutdown
- Active Load Sharing
- Current Walk-In
- Fan Cooling
- Adjustable Float & Equalize Voltage
- 4 Across Mounting in a 23" Configuration
- 2 Year Warranty

Controller

- Rack Mount
- Adjustable System Float & Equalize Voltage
- Float/Equalize Switch
- Multi-Mode Equalize Timer
- Alarms & Indicators
- LCD Display

Options

- 3 Across Mounting in a 19" Configuration
- AC & DC Breakers

Communication Protocols

- 21J** IEC61850
- 21P** DNP 3.0 Communications
RS232/RS485/Ethernet
- 21Q** Modbus Communications
RS232/RS485/Ethernet
- 21S** Modbus RTU - Serial Data Port
- 21X** SNMP



TABLE OF CONTENTS

	Model Number	DC Output		AC Input Phase	Nominal Current Draw @ 100% Load (Amps)	Overall Dimensions W x D x H	Cable Entry (when facing unit)		Mounting	Shipping Weight	
		Amps	Volts				AC Input	DC Output		lbs	kgs
Rectifier	A96-20-130-V1	20	130	1	15	5.25" x 14.5" x 7" 133 x 368 x 178 mm	---	---	---	14	6.4
Shelf	PC96-80-130V-23	Up to 80	130	1	Up to 60	21.38" x 25.85" x 7" 543 x 656.59 x 178 mm	LEFT	RIGHT	23" Rack/4RU	40	18.2

	Model Number	DC Output			Overall Dimensions W x D x H	Mounting	Shipping Weight	
		No. of Rectifiers	Amps	Voltage			lbs	kgs
Controller	C9623-80A-130V-01	Up to 4	Up to 80	130 VDC	23" x 3.075" x 6.97" 584.2 x 78.1 x 177mm	23" Rack/4RU	15	6.8
	C9623-160A-130V-01	Up to 8	Up to 160	130 VDC	23" x 3.075" x 6.97" 584.2 x 78.1 x 177 mm	23" Rack/4RU	15	6.8

INPUT

- **Input Voltage Range**
188-264VAC
- **Input Frequency Range**
45-66Hz
- **Power Factor**
Power factor correction circuitry corrects the input power factor to 0.99 at full-load.

OUTPUT

- **DC Output**
DC Amps: 20 to 160 amperes
DC Volts: 130VDC
- **Efficiency**
90%
- **Regulation**
Dynamic response (with battery). Maximum voltage transient will not exceed $\pm 10\%$ of initial steady state voltage for a step change from 20% to 100% of the full rated load. Recovery to steady state voltage regulation range does not exceed 50ms and all transient behavior disappears within 100ms.
- **Steady State**
Typical output voltage is $\pm 0.5\%$ of the setting from no load to full load over the specified input voltage, and ambient temperature ranges.

PROTECTION

- **Current Limit**
Maximum output current limited at 105% of its rated value.
- **Walk-In Circuit**
Output voltage will gradually increase after the charger is turned on, eliminating surges and over-shoot.
- **High Voltage Shutdown (HVSD)**
- **AC Fuse**
Each rectifier module is protected with an input fuse.

ADDITIONAL

- **Audible Noise**
Less than 54dBA at any point three feet from any vertical surface of the rectifier.
- **Cooling**
Fan Cooled

CONTROLS

- **Float Voltage**
130V Adjustable From 120-135V
- **Equalize Voltage**
130V Adjustable From 130-144V

FILTERING

- **Ripple Voltage**
With Battery Connected
< 30 mV RMS
Without Battery Connected
< 45 mV RMS

ENVIRONMENTAL

- **Operating Temperature**
0°C (32°F) to 55°C (130°F)
- **Storage Temperature**
-40°C (-40°F) to 85°C (185°F)
- **Humidity**
0% to 95% relative humidity, non-condensing

CONTROLLER SPECIFICATIONS



LED Indicators

- Fan Failure
- AC Failure
- Over-Temperature
- High Voltage Shutdown (HVSD)
- AC Available
- Current Limit
- Thermal Control
- DC Amps
- DC Volts
- Float
- Equalize
- Positive and Negative Ground

Alarm Relay Contacts 2 Form "C"

- High Voltage Shutdown (HVSD)
- Low DCA
- High DCV
- Low DCV
- AC Power Failure
- Summary
- Positive Ground*
- Negative Ground*

Float/Equalize Switch

- Rectifiers may be equalized locally via front panel switch

* 1 Set Form "C"



Unit shown: A97-60-130V-V1-60L

Unit shown: A97R-40-130V-V1

Utility Switchmode Rectifier

The La Marche A97 Series is a High Frequency Switchmode Rectifier System. This compact model provides highly reliable and efficient DC power. The A97 Rectifier System features current limiting circuitry, voltage regulation, high efficiency and high power factor, which makes it suitable for many DC applications.

The A97 model is equipped with a 2-line LCD display, alarm LED indicators and discrete alarm contacts to provide DC system status. This model is offered in 48V and 130V output capabilities. All A97 models operate over a range of 185-264 volts (45-66Hz) AC line. Its steady state output voltage remains within $\pm 0.5\%$ regulation of the setting from no load to full load to handle charging today's diverse battery technologies.

Standard Features

- High Frequency Switchmode Technology
- Battery Eliminator
- Power Factor of 0.99 at Full-Load
- Efficiency up to 93%
- Front Panel LCD Display Monitors DC Voltage, DC Amp and Alarm
- Adjustable Float / Equalize
- Multi-Mode Equalize Timer; Adjustable from 1-144 hrs with five selectable modes: Standard, 7-day, 14-day, 30-day and Auto Equalize on Low DC Voltage
- AC & DC Breaker
- Combination Alarm Package
- High Voltage Shutdown
- AC Power Failure Alarm with Form "C" Contacts
- Walk-In Circuit
- 1-Year Warranty

Optional Accessories

086 Wheeled Cart for A97W

Communication Protocols

21J IEC61850

21P DNP 3.0 Communications
RS232/RS485/Ethernet

21Q Modbus Communications
RS232/RS485/Ethernet

21S Modbus RTU - Serial Data Port

21X SNMP



Unit shown with Wheeled Cart 086 Option



TABLE OF CONTENTS

	Model Number	DC Output		AC Input Phase	DC Breaker	Nominal Current Draw @ 100% Load (Amps)	AC Feeder Breaker Size	Case No.	Overall Dimensions W x D x H	Cable Entry (when facing unit)		Mounting	Shipping Weight	
		Amps	Volts							AC Input	DC Output		lbs	kgs
48 VDC 24L or 37NC	A97R-50-48V-V1	50	48	1	60	15	20	96RW	16.4 x 18.38 x 8.75	RIGHT/BACK	LEFT/BACK	19/23" Rack	49	22.3
	A97R-100-48V-V1	100	48	1	120	30	35	96RW	417 x 467 x 222 mm	RIGHT/BACK	LEFT/BACK	19/23" Rack	60	27.3
	A97W-50-48V-V1	50	48	1	60	15	20	96RW	19.02 x 9.30 x 18.38	RIGHT/TOP/BOTTOM	LEFT/TOP/BOTTOM	WALL	49	22.3
	A97W-100-48V-V1	100	48	1	120	30	35	96RW	483 x 236 x 467 mm	RIGHT/TOP/BOTTOM	LEFT/TOP/BOTTOM	WALL	60	27.3
	A97-150-48V-V1	150	48	1	200	45	60	4	19 x 15 x 24	RIGHT	LEFT	19" or 23" RACK/WALL/FLOOR	130	59.1
	A97-150-48V-V3	150	48	3	200	28	50	4	483 x 381 x 610 mm	RIGHT	LEFT	RACK/WALL/FLOOR	130	59.1
130 VDC 60L or 92NC	A97R-20-130V-V1	20	130	1	25	15	20	96RW	16.4 x 18.38 x 8.75	RIGHT/BACK	LEFT/BACK	19/23" Rack	49	22.3
	A97R-40-130V-V1	40	130	1	50	30	35	96RW	417 x 467 x 222 mm	RIGHT/BACK	LEFT/BACK	19/23" Rack	60	27.3
	A97W-20-130V-V1	20	130	1	25	15	20	96RW	19.02 x 9.30 x 18.38	RIGHT/TOP/BOTTOM	LEFT/TOP/BOTTOM	WALL	49	22.3
	A97W-40-130V-V1	40	130	1	50	30	35	96RW	483 x 236 x 467 mm	RIGHT/TOP/BOTTOM	LEFT/TOP/BOTTOM	WALL	60	27.3
	A97-60-130V-V1	60	130	1	70	45	60	4	19 x 15 x 24	RIGHT	LEFT	19" or 23" RACK/WALL/FLOOR	130	59.1
	A97-60-130V-V3	60	130	3	70	28	50	4	483 x 381 x 610 mm	RIGHT	LEFT	RACK/WALL/FLOOR	130	59.1

INPUT

- Input Voltage Range**
185-264VAC
- Input Frequency Range**
45-66Hz
- Power Factor**
Power factor correction circuitry corrects the input power factor to 0.99 at full-load.

OUTPUT

- DC Output**
DC Amps: 20 to 150 amperes
DC Volts: 48 & 130VDC
- Regulation**
Dynamic response (with battery). Maximum voltage transient will not exceed $\pm 10\%$ of initial steady state voltage for a step change from 20% to 100% of the full rated load. Recovery to steady state voltage regulation range does not exceed 50ms and all transient behavior disappears within 100ms.
- Steady State**
Typical output voltage is $\pm 0.5\%$ of the setting from no load to full load over the specified input voltage, and ambient temperature ranges.
- Current Limit**
Maximum output current limited at 105% of its rated value.

FILTERING

- Ripple Voltage**
With Battery Connected
< 30 mV RMS
Without Battery Connected
< 45 mV RMS
- Electromagnetic Interference (EMI)**
EMI (conducted or radiated) rated in accordance with FCC Part 15. Class "A" limits.

ENVIRONMENTAL

- Operating Temperature**
0°C (32°F) to 50°C (130°F)
- Storage Temperature**
-40°C (-40°F) to 85°C (185°F)
- Humidity**
0% to 95% relative humidity, non-condensing

PROTECTION

- Walk-In Circuit**
Output voltage will gradually increase after the charger is turned on, eliminating surges and over-shoot.
- High Voltage Shutdown**
Included
- AC Breaker**
Single Phase
2-pole circuit breaker.
Three Phase
3-pole circuit breaker.
- DC Breaker**
2-pole circuit breaker.

ADDITIONAL

- Audible Noise**
Less than 54dBa at any point three feet from any vertical surface of the rectifier.
- Cooling**
Fan Cooled

CONTROLS

- Float/Equalize Switch**
Rectifier may be equalized locally via front panel switch.
- Float Voltage**
48V Adjustable From 50.8-54V
130V Adjustable From 120-135V
- Equalize Voltage**
48V Adjustable From 54-58V
130V Adjustable From 130-144V

COMBINATION ALARM PACKAGE (STANDARD)



Shown Above A97 Display

LED Indicators

- Fan Failure
- AC Failure
- Over-Temperature
- HVSD
- AC Available
- Current Limit
- Thermal Control
- DC Amps
- DC Volts
- Float
- Equalize
- Positive and Negative Ground

Relay Contacts

2 Form "C"

- HVSD
- Low DCA
- High DCV
- Low DCV
- AC Power Failure
- Summary
- Positive Ground*
- Negative Ground*

* 1 Set Form "C"

Model Number Nomenclature

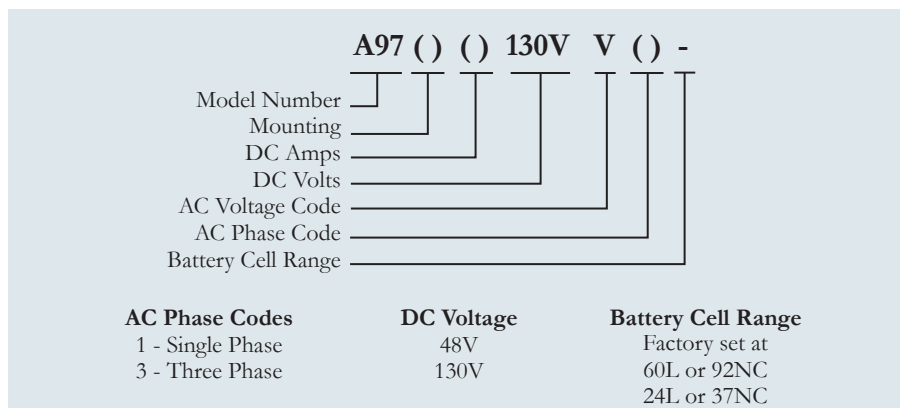



Load Distribution Center

La Marche LDC delivers the highest level of circuit protection and offers a robust and innovative configuration that simplifies any installation. It is available in four different models: 8, 12, 20, and 24 circuit breaker positions, with the option to include a main breaker. The LDC breakers are 2 pole, 250 VDC and minimum 10 kAIC rated. Loads are connected directly to the breaker, in order to establish a more secure and reliable connection. The field installable breaker kits makes future expansion much simpler.

In order to prevent accidental contact, the enclosure includes a hinged front access door and protective front cover.



Standard Features

- UL 489 Listed Breakers
- 250 VDC @ 10 KAIC
- NEMA 1 Enclosure
- 8, 12, 20, 24 Positions
- Top/Bottom Conduit Entry

OPTIONAL: (48N) No Conduit Holes

8 Position

- 400 amp bus rating
- Main Breaker up to 400A
Available breaker ratings:
100, 125, 150, 175, 200, 225, 250, 300, 400
- 2 positions for Branch Breakers from 125-250A
Available breaker ratings:
125, 150, 175, 200, 225, 250
- 6 positions for Branch Breakers up to 100A
Available breaker ratings:
15, 20, 25, 30, 40, 50, 60, 70, 80, 90, 100

12 Position

- 250 amp bus rating
- Main Breaker up to 250A
Available breaker ratings:
100, 125, 150, 175, 200, 225, 250
- Branch Breakers up to 100A
Available breaker ratings:
15, 20, 25, 30, 40, 50, 60, 70, 80, 90, 100



Door Removed

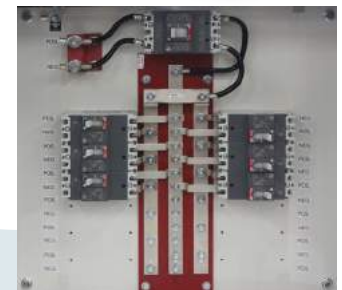

Breaker Cover Removed

20 Position

- 400 amp bus rating
- Main Breaker up to 400A
Available breaker ratings:
100, 125, 150, 175, 200, 225, 250, 300, 400
- 4 positions for Branch Breakers from 125-250A
Available breaker ratings:
125, 150, 175, 200, 225, 250
- 16 positions for Branch Breakers up to 100A
Available breaker ratings:
15, 20, 25, 30, 40, 50, 60, 70, 80, 90, 100

24 Position

- 250 amp bus rating
- Main Breaker up to 250A
Available breaker ratings:
125, 150, 175, 200, 225, 250
- Branch Breakers up to 100A
Available breaker ratings:
15, 20, 25, 30, 40, 50, 60, 70, 80, 90, 100





La MARCHÉ

ISO 9001:2008 CERTIFIED

TABLE OF CONTENTS

8 Position

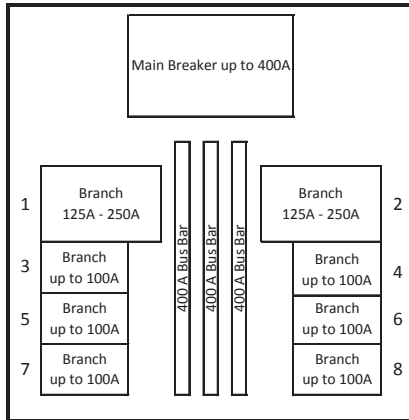

12 Position

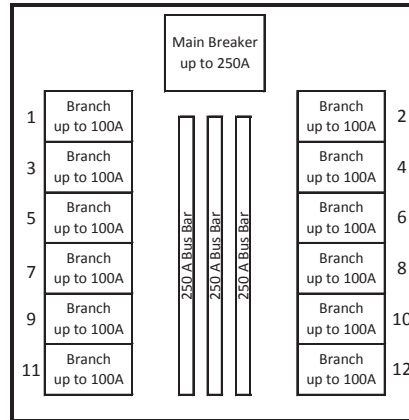

Dimension Chart

Circuit Breaker Position	Overall Dimensions (H x W x D)
8	24" x 24" x 6.75" 610mm x 610mm x 170mm
12	24" x 24" x 6.75" 610mm x 610mm x 170mm
20	36" x 24" x 6.75" 914mm x 610mm x 170mm
24	36" x 24" x 6.75" 914mm x 610mm x 170mm

20 Position

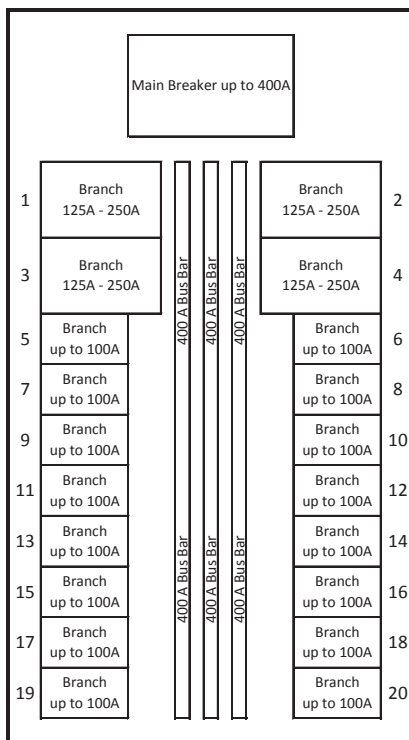

24 Position

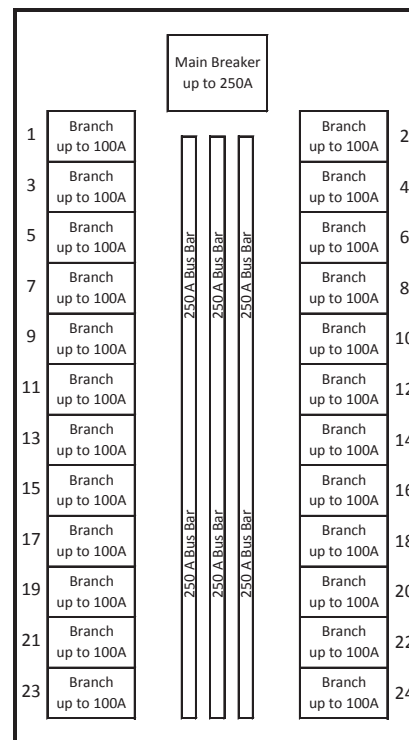

Ordering Information

When Ordering, Please Specify:

- La Marche Model Number
- Number of Breaker Positions
- Main Breaker Rating
- Branch Breakers Ratings
- Optional Accessories

Model Number Nomenclature

LDC - M100 - 12 - 20 - XXXXX

Model Number ————
 Main Breaker Rating ————
 M0 = No Main Breaker ————
 Breaker Positions ————
 Custom Configuration Code ————
 Breaker Combination Code ————

Breaker Positions

8, 12, 20, 24

La Marche Mfg. (A U.S. Company)
 106 Bradrock Drive, Des Plaines, IL 60018
 Tel: 847.299.1188 Fax: 847.299.3061
 sales@lamarchemfg.com
 www.lamarchemfg.com

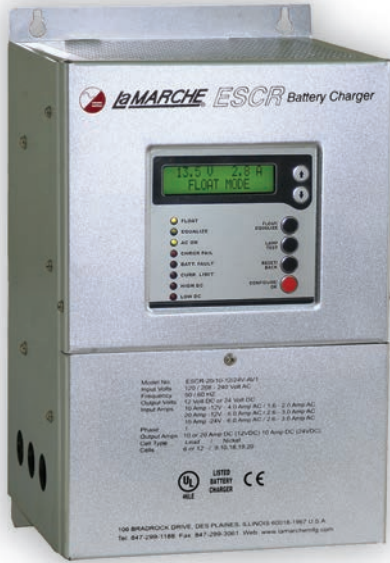

Unit Shown: ESCR-20/10-12/24V-AV1



ESCR Engine Starting Applications

The ESCR engine starting battery charger product line utilizes microprocessor controlled SCR Charging Technology. The PWM control provides the highest reliability that is required for maintaining and recharging engine start batteries for generator sets. This charger is suitable for various types of batteries such as flooded lead acid, VRLA and NiCad.

Automatic Input sensing for 120/208-240 VAC 50/60Hz does not require any tap changes. The (12V/24V) multi-output configuration capability makes this product line flexible and convenient for multiple jobs. The 0.5% regulation, temperature compensation, battery check, equalize timer along with adjustable output voltage and current limiting assures longevity and performance for your batteries. This economical solution equipped with advanced features incorporates La Marche quality and reliability.

The front panel is equipped with LCD display, alarm status LED's and controls. The two-line LCD displays output voltage and current along with alarm status text description. Individual LED indicators provide local supervision.

Form "C" contacts are available for remote annunciation. Push button controls are used for Float/Equalize mode, Reset, Lamp Test and Configure. This multi-input/output all-in-one unit meets NFPA 110, C62.41A and UL safety requirements. It is also certified for seismic applications in accordance with International Building Code (IBC) & OSHPD / California Building Code.

Standard Features

- Microprocessor Controlled SCR Technology
- Auto Select Input 120/208-240 VAC, 50/60Hz
- Field Selectable Output 12/24 VDC (Selected Models)
- Available Output Ranges 6-40 Amps
- LCD Display
- Alarm LED's and Form "C" Contacts
- Adjustable Float and Equalize Voltages
- Automatic AC Input Voltage Compensation
- AC to DC Isolation
- Filtering Suitable for VRLA Batteries
- Battery Fault Detection
- Internal Temperature Compensation
- Multimode Equalize Timer
- Powder Coated Aluminum Enclosure
- Soft Start
- Adjustable Current Limiting
- Meets NFPA 110 and C62.41A
- UL 1236 Listed

- CE Certified
- IBC Certified for seismic applications
- OSHPD Certified
- ABS Approved
- 3 Year Warranty

Optional Accessories

- 080** Drip Shield
- 09P** Conformal Coated Circuit Boards
- 101** 3 Battery Charge Divider - Negative Common
- 11W** External Temperature Compensation Probe
- 18L** Output Disconnect Relay
- 530** CUL Listing
- 38H** ABS Certified Report
- 140** AC ON/OFF Switch
- 316** Battery Test (only available for single voltage units)
- 537** OSHPD Certification Label (consult factory for Anchor Kits)
- 538** IBC Certification Label (consult factory for Anchor Kits)



TABLE OF CONTENTS

Model Number	DC Output		AC Input		Overall Dimensions W x D x H	Case No.	Shipping Weight	
	Volts (Nominal)	Amps	Volts (Nominal)	Amps			lbs	kgs
ESCR-6-12/24V-AV1*	12 24	6	120/208-240	3.0/1.5	6.4" x 7" x 9.35" 162 x 179 x 237mm	100	16	7
ESCR-10-24V-AV1	24	10	120/208-240	6.0/3.0	7.75" x 7" x 11.25" 197 x 179 x 285mm	98	25	11
ESCR-20/10-12/24V-AV1	12 12 24	10 20 10	120/208-240	3.2/1.6 5.4/3.0 6.0/3.0	7.75" x 7" x 11.25" 197 x 179 x 285mm	98	25	11
ESCR-20-24V-AV1	24	20	120/208-240	12.1/6.1	11.38" x 9" x 15" 289 x 229 x 381mm	99	42	19
ESCR-40/20-12/24V-AV1	12 24	40 20	120/208-240	10.9/5.9 12.1/6.1	11.38" x 9" x 15" 289 x 229 x 381mm	99	42	19
ESCR-10-32V-AV1*	32	10	120/208-240	7.0/3.5	7.75" x 7" x 11.25" 197 x 179 x 285mm	98	25	11
ESCR-20-32V-AV1*	32	20	120/208-240	14.0/7.0	11.38" x 9" x 15" 289 x 229 x 381mm	99	42	19

* Certifications pending

AC INPUT

- 120/208 - 240 VAC $\pm 10\%$, 50/60HZ, Single Phase

DC OUTPUT (Field Selectable)

- 6A @ 12V or 6A @ 24V
- 10A @ 12V or 20A @ 12V or 10A @ 24V
- 40A @ 12V or 20A @ 24V
- 10A @ 32V
- 20A @ 32V

REGULATION

- **Line:** $< \pm 0.5\%$
- **Load:** $< \pm 0.5\%$

OUTPUT FILTERING

(W/ Battery Connected)

- **< 500 mV RMS**

PROTECTION

- **Input**
Fuse with Surge Protection
- **Output**
Fuse with Surge Protection
Reverse Polarity Protection

BATTERY CELL SELECTION

- | | |
|-------------------|-------------------|
| • 12 Volts | • 32 Volts |
| 6L | 16L |
| 9NC | 24NC |
| 10NC | 25NC |
| • 24 Volts | • 26NC |
| 12L | |
| 18NC | |
| 19NC | |
| 20NC | |

OUTPUT CURRENT LIMIT

- Factory set at 105%
Adjustable from 50 - 105%

METERING

- LCD DC Output Digital Voltmeter and Ammeter (1%)

ADJUSTABLE VOLTAGE RANGE

- **Float Voltage**
2.12 - 2.3 volts/cell (Lead)
1.39 - 1.45 volts/cell (NiCad)
- **Equalize Voltage**
2.25 - 2.40 volts/cell (Lead)
1.45 - 1.6 volts/cell (NiCad)

CONTROLS

- **Float and Equalize Button**
Switch from Float to Equalize
- **Configure Button**
Output Settings
Voltage and Cells
Adjust Voltage for Float & Equalize
Adjust Alarm Settings and Delay
Enable/Disable Temperature Compensation
Equalize Timer
~ Multi-Mode Equalize Timer and Light;
adjustable from 1 - 144 hrs
~ Five selectable modes: Manual, 7-day, 14-day,
30-day and Equalize after Low DC Voltage
and/or AC Failure
- **Reset Button**
Restarts the Unit
- **Lamp Test Button**
Tests LCD Display & LED's

ALARM CONTACTS

- AC Failure
 - Low DC Voltage
 - High DC Voltage
 - Charger Failure
- Form "C" contact rated 2A @ 30VDC/0.5A @ 125VAC

MONITORING

- **LCD Display**
Volts
Amps
Status
- **LED Indications**
Float (Green)
Equalize (Yellow)
AC ON (Green)
Charger Failure (Red)
Battery Fault (Red)
Current Limit (Red)
High DC Voltage (Red)
Low DC Voltage (Red)

ENVIRONMENTAL

- **Operating**
-20° to 50° C
- **Storage**
-40° to 85° C
- **Relative Humidity**
5% to 95% non-condensing

ENCLOSURE

- **Structural Design**
Wall Mount NEMA 1 powder coated
- **Cable Entry**
Left Side
6A model - Knockouts: left (2),
right (1) and back (3)

STANDARDS

- | | |
|----------------|------------|
| • UL1236 | • OSHPD** |
| • CE | • ABS*** |
| • Optional CUL | • NFPA 110 |
| • IBC** | • C62.41A |

** Refer to the manual for mounting information

*** May require Drip Shield based on site requirements

Model Number Nomenclature

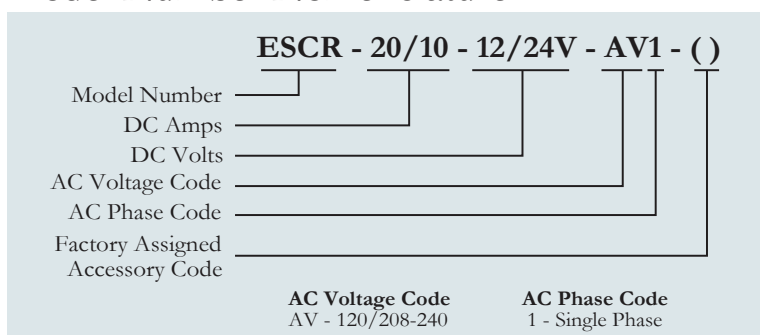

Front Panel Display





Unit Shown: ESCR-50-24V-AV1



ESCR II Engine Starting Applications

The ESCR engine starting battery charger product line utilizes microprocessor controlled SCR Charging Technology. The PWM control provides the highest reliability that is required for maintaining and recharging engine start batteries for generator sets. This charger is suitable for various types of batteries such as flooded lead acid, VRLA and NiCad.

The 0.5% regulation, temperature compensation, battery check, equalize timer along with adjustable output voltage and current limiting assures longevity and performance for your batteries. This economical solution equipped with advanced features incorporates La Marche quality and reliability.

The front panel is equipped with LCD display, alarm status LED's and controls. The two-line LCD displays output voltage and current along with alarm status text description. Individual LED indicators provide local supervision.

Form "C" contacts are available for remote annunciation. Push button controls are used for Float/Equalize mode, Reset, Lamp Test and Configure. This all-in-one unit meets NFPA 110, C62.41A and UL safety requirements. The ESCR II units are certified for seismic applications in accordance with the International Building Code (IBC).

Standard Features

- Microprocessor Controlled SCR Technology
- Tap Select Input 120/208-240 VAC, 50/60Hz
- LCD Display
- Alarm LED's and Form "C" Contacts
- Adjustable Float and Equalize Voltages
- Automatic AC Input Voltage Compensation
- AC to DC Isolation
- Filtering Suitable for VRLA Batteries
- Battery Fault Detection
- Internal Temperature Compensation
- Multimode Equalize Timer
- AC & DC Breakers
- Soft Start
- Adjustable Current Limiting
- Meets NFPA 110 and C62.41A
- UL/CUL 1236 Listed
- CE Certified
- IBC Certified for seismic applications
- ABS Approved
- 3 Year Warranty

Optional Accessories

- 080** Drip Shield
- 09P** Conformal Coated Circuit Boards
- 101** 3 Battery Charge Divider - Negative Common
- 11W** External Temperature Compensation Probe
- 38H** ABS Certified Report
- 538** IBC Certification Label (consult factory for Anchor Kits)



TABLE OF CONTENTS

Model Number	DC Output		AC Input		Overall Dimensions W x D x H	Case No.	Shipping Weight	
	Volts (Nominal)	Amps	Volts (Nominal)	Amps			lbs	kgs
ESCR-30-24V-AV1	24	30	120/208-240	18/9-8	16.8" x 10.6" x 19.7" 427.7 x 269.9 x 500.4mm	7-44	118	53.5
ESCR-40-24V-AV1	24	40	120/208-240	22/11-10	16.8" x 10.6" x 19.7" 427.7 x 269.9 x 500.4mm	7-44	125	56.7
ESCR-50-24V-AV1	24	50	120/208-240	26/14-13	16.8" x 10.6" x 19.7" 427.7 x 269.9 x 500.4mm	7-44	130	58.9

AC INPUT

- 120/208 - 240 VAC $\pm 10\%$, 50/60HZ, Single Phase

DC OUTPUT

- 30A @ 24V
- 40A @ 24V
- 50A @ 24V

REGULATION

- Line:** $< \pm 0.5\%$
- Load:** $< \pm 0.5\%$

OUTPUT FILTERING

(W/ Battery Connected)

- < 500 mV RMS**

PROTECTION

- Input**
Breaker with Surge Protection
- Output**
Breaker with Surge Protection

BATTERY CELL SELECTION

- 24 Volts**
12L
18NC
19NC
20NC

OUTPUT CURRENT LIMIT

- Factory set at 105%
Adjustable from 50 - 105%

METERING

- LCD DC Output Digital Voltmeter and Ammeter (1%)

ADJUSTABLE VOLTAGE RANGE

- Float Voltage**
2.12 - 2.3 volts/cell (Lead)
1.39 - 1.45 volts/cell (NiCad)
- Equalize Voltage**
2.25 - 2.40 volts/cell (Lead)
1.45 - 1.6 volts/cell (NiCad)

CONTROLS

- Float and Equalize Button**
Switch from Float to Equalize
- Configure Button**
Output Settings
Voltage and Cells
Adjust Voltage for Float & Equalize
Adjust Alarm Settings and Delay
Enable/Disable Temperature Compensation
Equalize Timer
~ Multi-Mode Equalize Timer and Light;
adjustable from 1 - 144 hrs
~ Five selectable modes: Manual, 7-day, 14-day, 30-day and Equalize after Low DC Voltage and/or AC Failure (Default Factory Setting)
- Reset Button**
Restarts the Unit
- Lamp Test Button**
Tests LCD Display & LED's

ALARM CONTACTS

- AC Failure
 - Low DC Voltage
 - High DC Voltage
 - Charger Failure
- Form "C" contact rated 2A @ 30VDC/0.5A @ 125VAC

MONITORING

- LCD Display**
Volts
Amps
Status
- LED Indications**
Float (Green)
Equalize (Yellow)
AC ON (Green)
Charger Failure (Red)
Battery Fault (Red)
Current Limit (Red)
High DC Voltage (Red)
Low DC Voltage (Red)

ENVIRONMENTAL

- Operating**
-20° to 50° C
- Storage**
-40° to 85° C
- Relative Humidity**
5% to 95% non-condensing

ENCLOSURE

- Structural Design**
Wall/Floor Mount NEMA 1 powder coated
- Cable Entry**
Both sides

STANDARDS

- UL 1236
- CUL
- NFPA 110
- C62.41A
- CE
- IBC*
- ABS**

* Refer to the manual for mounting information

** May require Drip Shield based on site requirements

Model Number Nomenclature

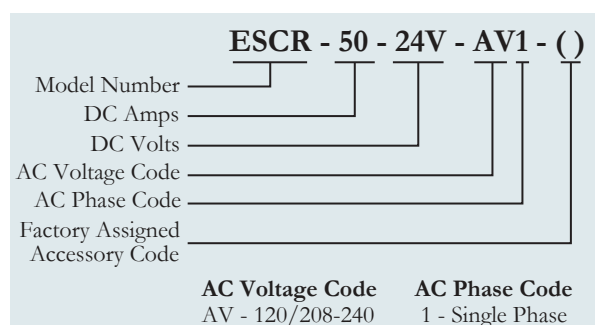

Front Panel Display



Engine Starting Battery Charger



Standard



16 Series CAP



46 Series CAP



The La Marche A46/A46F battery charger is specially designed for maintaining and recharging starting batteries of engine generator sets. The controlled magnetic amplifier technology provides the highest reliability that is necessary for the continued operation of the emergency standby equipment and eliminates most starting problems by maintaining batteries at a proper charge, ensuring optimum performance and maximum life.

These chargers can also be customized to meet the American Bureau of Shipping (ABS) and United States Coast Guard (USCG) standards for applications such as offshore and on board vessels.

Standard Features

- Magnetic Amplifier Circuitry
- Automatic DC Voltage Regulation
- Automatic AC Input Voltage Compensation +/- 10%
- Automatic Surge Suppression
- Analog DC Ammeter & DC Voltmeter
- DC Current Limiting Circuitry
- AC Input and DC Output Fusing
- AC Power Failure Relay with (1) set of Form “C” Contacts
- Float/Equalize Mode Switching
- Charger design prevents battery from discharging if AC line fails
- AC to DC Isolation
- Model A46F is filtered for Valve-Regulated batteries
- UL 1564 Listed and C-UL Listed
- 10-Year Limited Warranty



A46 & A46F Models

Model Number All Models Available As A46F	DC Output			AC Input Current Draw* at 100% Load (Amps)				A46 Case No.	A46 Shipping Weight (Approximate)		A46F Case No.	A46F Shipping Weight (Approximate)		
	Amps	Volts	Fuse Size	A 120	D 208	B 240	C 480		lbs	kgs		lbs	kgs	
12VDC 6L, 9 or 10NC	A46-6-12V	6	12V	15A	1.5	0.9	0.8	--	1	28	12.7	2	39	17.8
	A46-10-12V	10	12V	20A	2.5	1.4	1.3	--	1	30	13.6	2	41	18.7
	A46-20-12V	20	12V	35A	5	2.9	2.5	--	2	56	25.4	7	68	31.0
	A46-30-12V	30	12V	50A	7.5	4.3	3.8	--	2	66	29.9	3	91	41.4
24VDC 12L, 19 or 20NC	A46-6-24V	6	24V	15A	3	1.7	1.5	--	1	38	17.2	7	50	22.8
	A46-10-24V	10	24V	20A	5	2.9	2.5	--	2	62	28.1	7	74	33.7
	A46-20-24V	20	24V	35A	10	5.8	5	--	2	73	33.1	7	85	38.7
	A46-30-24V	30	24V	50A	15	8.7	7.5	--	7	108	49.0	3	127	57.8
	A46-40-24V	40	24V	70A	21	12	10	--	7	112	50.8	3	143	65.0
	A46-50-24V	50	24V	80A	26	14.6	13	6.5	3	140	63.5	4	148	67.1
32VDC 16L	A46-6-32V	6	32V	15A	4	2.3	2	--	2	58	26.3	7	70	31.9
	A46-10-32V	10	32V	20A	6.7	3.9	3.3	--	2	68	30.8	7	80	36.4
	A46-20-32V	20	32V	35A	14	7.7	6.7	--	2	74	33.6	3	92	41.9
	A46-30-32V	30	32V	50A	21	12	10	--	7	112	50.8	3	131	59.6
36VDC 18L	A46-6-36V	6	36V	15A	4.5	2.7	2.4	--	2	58	26.3	7	70	31.9
	A46-10-36V	10	36V	20A	7.5	4.2	3.9	--	2	68	30.9	7	80	36.4
	A46-20-36V	20	36V	35A	15	8.7	7.5	--	7	74	33.6	3	92	41.9
	A46-30-36V	30	36V	50A	22.5	12.9	11.4	--	7	112	50.8	3	131	59.6

Case Specifications

Case No.	Overall Dimensions Width x Depth x Height
1	10" x 8" x 16" 264 x 200 x 413mm
2	13" x 10" x 17" 326 x 254 x 435mm
3	15" x 11" x 24" 391 x 279 x 603mm
4	19" x 15" x 26" 483 x 381 x 658mm
7	14" x 11" x 20" 362 x 270 x 505mm

Note: All above models designed for optimal performance at 60Hz. They will operate at 50Hz with reduced performance. Consult factory for units designed specifically at 50Hz. Must specify only one battery type and number of cells. Please consult factory for other available cell ranges if desired range not shown.
*AC Current Draws based @ 100% load using standard battery cells of 6L(12V), 12L(24V), 18L(36V)
Maximum current Draw is typically 140% of ratings shown.

Options

Circuit Breakers

- **011** AC Breaker Single Pole (120VAC only)
- **012** DC Breaker Single Pole
- **016** AC Breaker Two Pole
- **017** DC Breaker Two Pole

Choose options from Discrete or Combination Accessory Packages (C.A.P.)

Discrete

(Choose one or more of the options in this category)

- **055** Float Light
- **056** Equalize Light
- **060** AC Pilot Light
- **04J** Multi-Mode Equalize Timer & Lights
Adjustable from 1-144hrs in (5) selectable modes; Standard, 7-day, 14-day, 30-day and Equalize after Low DC Voltage. Includes Float and Equalize Lights (055 and 056)

Combination Accessory Packages (C.A.P.)

- **16E** Digital C.A.P. system (Meets NFPA 110)
Features a selectable LED display along with the AC Pilot Light, Equalize Timer and many more features (Refer to the Digital C.A.P. System data sheet for complete details).
- **16J** Digital C.A.P. System (Meets NFPA 110)
Includes all the features of 16E package (above) plus Ground Detection Alarm (Refer to the Digital C.A.P. System data sheet for complete details).
- **46E** LCD C.A.P. system (Meets NFPA 110)
Features Selectable Display, Multi-Mode Equalize Timer, Equalize light, Float Light and many more features (Refer to the Digital LCD System data sheet for complete details).
- **46J** LCD C.A.P. system (Meets NFPA 110)
Includes all the features of 46E package (above) plus Ground Detection Alarm (Refer to the LCD C.A.P. System data sheet for complete details).
- **204** C.A.P.system (Meets NFPA 110)
Includes (1) set of form "C" contacts for AC Power Failure. Low DC Voltage, High DC Voltage, and Low DC Current.
- **03M** Low/High DC Voltage Alarm & Lights with (1) set of Form "C" contacts each for Low Voltage & High Voltage w/LED's

ABS/USCG (U.S. Coast Guard)

- **10B** U.S.C.G. Accessories, includes a drip shield, on/off switch & water tight connectors.
- **38G** ABS (American Bureau of Shipping) Type Approval with option 060, 16E or 16J.
- **38J** ABS & U.S.C.G. Accessories with option 060, 16E or 16J.

Internal Charge Dividers

(consult factory may increase case size)

- **100** To charge 2 batteries w/negative common.
- **10U** To charge 2 batteries w/positive common.
- **101** To charge 3 batteries w/negative common.
- **10V** To charge 3 batteries w/positive common.

Model Number Nomenclature

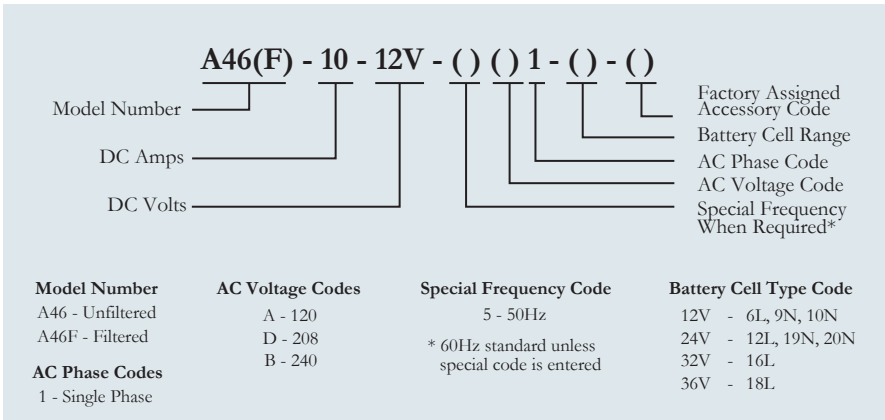

Environmental:

Operating Temperature:
0 to 50° C (32 to 122° F)

Storage Temperature:
-40 to 85° C (-40 to 185° F)

Relative Humidity:
0 to 95% non-condensing

- NEMA 1 enclosure ANSI 61 gray baked enamel paint



The Powerful Advantage Since 1945

La MARCHÉ

ISO 9001:2008 CERTIFIED

TABLE OF CONTENTS

USC SERIES

HIGH FREQUENCY ULTRA SERIES CHARGER



The La Marche Ultra Series Charger is a High Frequency Switch Mode charger specifically developed for Batteries and Ultra Capacitors used in starting applications. This programmable charger with filtered output is designed to charge various types of chemistries, such as Lead Acid, Nickel Cadmium and Ultra Capacitors.

The USC series incorporates Power Factor Correction (PFC) Circuitry with a wide input voltage range. The user friendly interface allows the user to navigate easily through the configuration menu. The two line LCD displays Output DC Voltage & Current and Alarm Status. The front of the unit provides four status LED indicators for the overall status of the system.

The case is designed using primed 16 Ga galvanized steel with powder coat finish for maximum strength against corrosion, while its weight gives the customer easy handling and installation, without the necessity of a second person. Case is equipped with knockouts, for optional cable entry, either from the sides or the bottom. Removable cover, located on the front, gives access to the customer connections, temperature probe, as well as, the alarm terminals.

Standard Features

- Microprocessor Controlled High Frequency Charging Technology
- Ultra Capacitor Module Charging Mode
- Float and Equalize Battery Charging Mode
- Filtered Output for VRLA (Gel-Cell & AGM) Batteries
- Single Phase AC Input (102-264 VAC, 45-65Hz)
- Complete Isolation from AC to DC
- Input & Output Protection Fuses
- Adjustable Current Limit from 50% to 105%
- LCD Digital Voltmeter & Ammeter
- Conformal Coated Circuit Boards
- Temperature Compensation (Internal) with Disable Option
- External Temperature Probe 24 feet
- Alarms with LED Indicators and Form "C" Dry Type Relay Contacts
- IP20/NEMA Type 1
- Meets NFPA 110 and ANSI C62.41A
- UL and CUL 1236
- 2-Year Warranty

Optional Accessories

- 21S Modbus Communication
- 080 Drip Shield (IP22/NEMA Type 2)
- 11Y External Temperature Probe 100 feet

Specifications subject to change without notice

La Marche Mfg. (A U.S. Company)

106 Bradrock Drive, Des Plaines, IL 60018

Tel: 847.299.1188 Fax: 847.299.3061

sales@lamarchemfg.com

www.lamarchemfg.com



Model Number Chart

Model Number	AC Input (100% load)		DC Output		Overall Dimensions W x D x H	Case No.	Net Weight*	
	Volts (Nominal)	Amps	Volts (Nominal)	Amps			lbs	kgs
USC-10-12V-U1	120	1.5	12	10	7.9 x 4.1 x 11.0 in 201 x 105 x 279.4 mm	104	5	2.9
	240	0.8						
USC-20-12V-U1	120	3.1	12	20	7.9 x 4.1 x 11.0 in 201 x 105 x 279.4 mm	104	5	2.9
	240	1.6						
USC-30-12V-U1**	120	4.4	12	30	9.6 x 4.6 x 15.9 in 244 x 117 x 404 mm	107	11.3	5.1
	240	2.3						
USC-10-24V-U1	120	2.6	24	10	7.9 x 4.1 x 11.0 in 201 x 105 x 279.4 mm	104	5	2.9
	240	1.4						
USC-20-24V-U1**	120	5.2	24	20	9.6 x 4.6 x 15.9 in 244 x 117 x 404 mm	107	11.3	5.1
	240	2.7						
USC-30-24V-U1**	120	7.8	24	30	9.6 x 4.6 x 15.9 in 244 x 117 x 404 mm	107	11.3	5.1
	240	3.8						

* Weight does not include shipping packaging

** UL pending

Charger Specifications

• AC Input

Single Phase Input

AC Input Range (102 - 264 VAC, 45 - 65 Hz)

DC Input Range (105 - 140 Vdc)

• DC Output

10A/12V, 20A/12V, 30A/12V

10A/24V, 20A/24V, 30A/24V

• Power Factor

0.99

• Load Regulation

<±0.5%

• Output Filtering (with or without connected battery)

<1% of Output Voltage

• Input Protection

Fuse with Surge and Transient Protection

AC Over Voltage Protection

• Output Current Limit

Factory set at 100%, adjustable from 50-105%

• Output Protection

Fuse with Surge Protection

Blocking Diode

• Thermal Protection

• Short Circuit Protection

• LCD Digital Display

DC Output Voltmeter and Ammeter (1%)

• LED Indicators

AC ON Equalize

Float Fault

• Alarm Contacts

Charger Fail High DC Voltage

AC Fail Low DC Voltage

Summary

• Environmental

Operating: -40° to 65°C (-40° to 149°F) (Derated up to 70°C)

Storage: -40° to 85°C (-40° to 185°F)

Relative Humidity: 0 to 95% non condensing

• Battery Charging Voltage Range

Float*:

Lead Acid 2.12-2.30 Volt/Cell

NiCad 1.39-1.45 Volt/Cell

Equalize*:

Lead Acid 2.25-2.40 Volt/Cell

NiCad 1.45-1.60 Volt/Cell

* Ultracapacitor (not applicable)

• Mounting

Wall Mount

• Cooling

Fan Assisted

• Cable Entry

Left / Right / Bottom

• Enclosure

NEMA 1

• Standards

UL / CUL 1236

ANSI C62.41A

EN 60335-1 (Electrical Safety)

IEC 60335-2-29 (Electrical Safety)

IEC 60068-2-6 (Sinusoidal Vibration)

EN 55011 (Radiated EMI)

IEC 1000-4-2 (Electrostatic Discharge)

IEC 1000-4-4 (Electrical Fast Transient)

Front Display Panel



Model Number Nomenclature

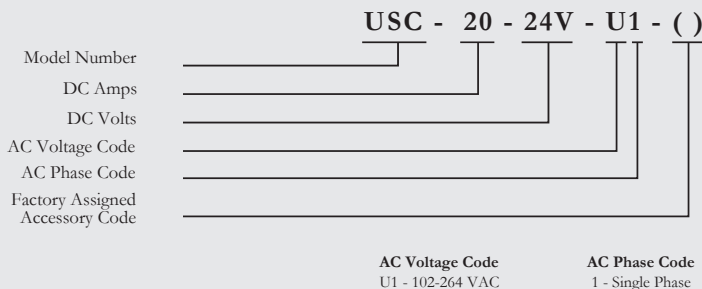



Automatic Float Charger

The La Marche EC Charger uses proven Ferroresonant charging technology. It is a completely automatic, solid state, constant voltage battery charger that will sense the battery condition and deliver the appropriate output current to recharge it.

The EC is designed and built to charge Flooded Lead-Acid or Nickel Cadmium Batteries containing a specific number of cells. For Valve Regulated Batteries use our models A40F, A46F or ESCR.

Our optional 204 C.A.P. System is designed to meet NFPA 110 requirements. It consists of (1) Form "C" contact for each of the following: AC Power Failure, Low DC Current, Low DC Voltage and High DC Voltage. These are provided for monitoring the condition of the Battery Charger and Battery Bank.

Model Number	DC Output		120 VAC Current Draw* @ 100% Load (Amps)	Overall Dimensions W x D x H	Cable Entry (when facing unit)		Mounting	Shipping Weight (approx.)	
	Amps	Volts			AC Input	DC Output		lbs	kgs
EC-6-12V-A1	6	12V	1.0	9.00" X 8.70" X 11.50" 229 x 221 x 292 mm	LEFT	RIGHT	WALL	18	8
EC-10-12V-A1	10	12V	1.5	9.00" X 8.70" X 11.50" 229 x 221 x 292 mm	LEFT	RIGHT	WALL	21	9.5
EC-10-24V-A1	10	24V	3.0	9.00" X 8.70" X 11.50" 229 x 221 x 292 mm	LEFT	RIGHT	WALL	22	10
EC-20-24V-A1	20	24V	6.1	13.38" x 8.69" x 16.50" 340 x 221 x 419 mm	LEFT	RIGHT	WALL	38	17.3

* Maximum Current draw is typically less than 150% of ratings shown.

Standard Features

- Ferroresonant Charging Technology
- Stainless Steel NEMA-1 Enclosure
- Single Phase AC Input 120V AC 60Hz
- Float/Equalize switch & LED Indicators
- AC Circuit Breaker

- Analog DC Ammeter & Voltmeter
- UL 1564 Listed & CUL Listed
- 2-Year Warranty

Optional Accessories

204 Combined Accessory Package

Model Number Nomenclature

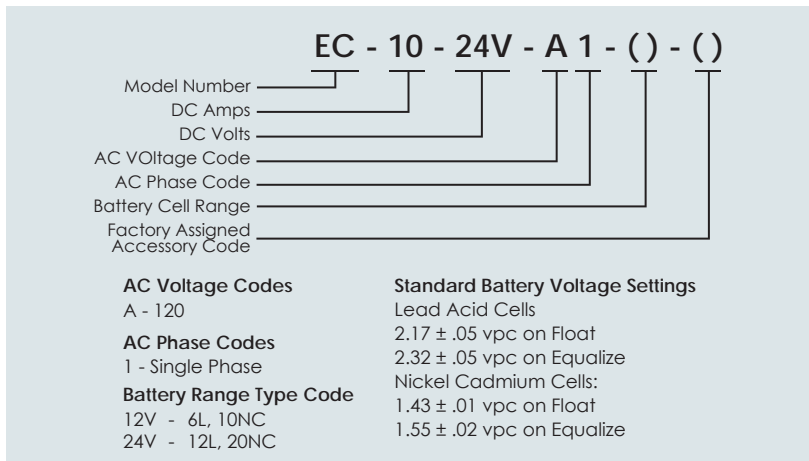

Ordering Information

When ordering, please specify:

- La Marche Model Number EC
- Input Voltage of 120VAC / 1 / 60Hz
- Number and Type of Battery Cells
- Ampere Hour Capacity of Battery
- Allowable Recharge Time from Full Discharge (where applicable)



Engine Starting Battery Charger

The La Marche model A40/A40F battery chargers are renowned throughout the industry as the Constavolt because of their reliability and their precise and constant output voltage to charge your batteries. The Constavolt is a completely automatic, solid state, constant voltage battery charger built to carry continuous and intermittent loads up to 80% of its maximum rated output capacity. It is ideal for applications where it is advantageous to have the charger permanently connected across the battery, keeping it charged at all times and to simultaneously carry continuous and/or intermittent current loads such as onboard peripheral equipment.

“Constavolt”

Standard Features

- Magnetic Amplifier Circuitry
- Automatic DC Voltage Regulation
- Automatic AC Input Voltage Compensation +/- 10%
- Automatic Surge Suppression
- AC input and DC output fusing protects battery and charger
- Analog DC Ammeter
- DC Current Limiting Circuitry
- Charger design prevents battery from discharging if AC line fails
- AC to DC Isolation
- Model A40F is filtered for Valve-Regulated batteries
- A40/A40F models are UL 1564 Listed & C-UL Listed
- 10-Year Limited Warranty

Environmental

- Operating Temperature: 0 to 50° C (32 to 122° F)
Storage Temperature: -40 to 85° C (-40 to 185° F)
Relative Humidity: 0 to 95% non-condensing

	Model Number All Models Available As A40F	DC Output			AC Input Current Draw* at 100% Load (Amps)			A40 Case No.	A40 Shipping Weight (Approximate)		A40F Case No.	A40F Shipping Weight (Approximate)	
		Amps	Volts	Fuse Size	A 120	D 208	B 240		lbs	kgs		lbs	kgs
12VDC 6L, 9 or 10NC	A40-10-12V	10	12V	20A	2.5	1.4	1.3	05	30	13.6	2	46	20.9
	A40-20-12V	20	12V	35A	5	2.9	2.5	2	54	24.5	7	66	30.0
	A40-30-12V	30	12V	50A	7.5	4.3	3.8	2	65	29.5	3	90	40.9
	A40-40-12V	40	12V	70A	10	5.8	5	2	74	33.6	4	133	60.5
	A40-60-12V	60	12V	100A	15	8.7	7.5	7	98	44.5	6	168	76.4
	A40-75-12V	75	12V	130A	19	11	9.4	3	123	55.9	6	187	85.0
	A40-100-12V	100	12V	150A	26	15	13	6	165	75.0	8A	260	118.2
24VDC 12L, 19 or 20NC	A40-10-24V	10	24V	20A	5	2.9	2.5	2	61	27.7	7	73	33.2
	A40-20-24V	20	24V	35A	10	5.8	5	2	72	32.7	7	84	38.2
	A40-30-24V	30	24V	50A	15	8.7	7.5	7	98	44.5	3	117	53.2
	A40-40-24V	40	24V	70A	21	12	10	7	105	47.7	3	136	61.8
	A40-60-24V	60	24V	100A	31	18	15	3	150	68.2	4	213	96.8
	A40-75-24V	75	24V	130A	38	22	19	3	210	95.5	6	274	124.5
	A40-100-24V	100	24V	150A	51	29	26	8A	300	136.4	8A	374	170.0
32VDC 16L	A40-10-32V	10	32V	20A	6.7	3.9	3.3	2	61	27.7	7	73	33.2
	A40-20-32V	20	32V	35A	14	7.7	6.7	2	72	32.7	3	90	40.9
	A40-30-32V	30	32V	50A	21	12	10	7	98	44.5	3	117	53.2
	A40-40-32V	40	32V	70A	27	16	14	3	140	63.6	4	187	85.0
	A40-60-32V	60	32V	100A	41	24	21	3	170	77.3	6	234	106.4
	A40-75-32V	75	32V	130A	51	29	26	8A	250	113.6	8A	291	132.3
130 VDC 60L / 92NC	A40-10-130V	10	130V	20A	26	15	13	3	155	70.5	4	183	83.2
	A40-20-130V	20	130V	35A	51	29	26	6	175	79.5	6	181	82.3
	A40-30-130V	30	130V	50A	76	44	38	8A	330	150.0	8A	343	155.9

All above models designed for optimal performance at 60Hz. They will operate at 50Hz with reduced performance. Consult factory for units designed specifically at 50Hz. Please consult factory for other available cell ranges if desired range not shown. *AC Current Draws based @100% load and standard battery cells of 6L(12V),12L(24V),16L(32V),60L(130V). Maximum Current Draw is typically 140% of ratings shown.

Case Specifications

Case No.	Overall Dimensions						Cable Entry (when facing unit)		Mounting
	Width		Depth		Height		AC input	DC output	
	in	mm	in	mm	in	mm			
05	8.000	203	7.000	178	13.000	330	BOTTOM RIGHT	BOTTOM RIGHT	WALL
1	10.375	264	7.875	200	16.250	413	RIGHT	LEFT	WALL
2	12.812	326	10.000	254	17.125	435	RIGHT	LEFT	WALL
3	15.375	391	11.000	279	23.750	603	RIGHT	LEFT	WALL/FLOOR
4	19.000	483	15.000	381	25.875	657	RIGHT/TOP/BOTTOM	LEFT/TOP/BOTTOM	WALL/FLOOR/RACK
6	25.580	650	13.935	354	28.000	711	RIGHT/TOP/BOTTOM	LEFT/TOP/BOTTOM	WALL/FLOOR
7	14.250	362	10.625	270	19.875	505	RIGHT	LEFT	WALL/FLOOR
8A	27.200	691	15.250	387	32.500	826	RIGHT	LEFT	FLOOR

Case sizes may differ depending on optional accessories. Please consult factory when dimensions are critical. Dimensions shown above are overall footprint. Detailed dimension drawings are available for mounting purposes.

Model Number Nomenclature

A40(F) - 10 - 12V - () () 1 - () - ()

Model Number: A40(F)
 DC Amps: 10
 DC Volts: 12V
 AC Voltage Code: ()
 AC Phase Code: ()
 Special Frequency Code: 1
 Battery Cell Type Code: () - ()

Factory Assigned Accessory Code
 Battery Cell Range
 AC Phase Code
 AC Voltage Code
 Special Frequency When Required*

Model Number	AC Voltage Codes	Special Frequency Code	Battery Cell Type Code
A40 - Unfiltered	A - 120	5 - 50Hz	12V - 6L, 9N, 10N
A40F - Filtered	D - 208	* 60Hz standard unless special code is entered	24V - 12L, 19N, 20N
	B - 240		32V - 16L
			130V - 60L, 92N

Optional External Charge Dividers

Model Number	Number of Batteries	DC Range		Case No.	Shipping Weight (Approximate)	
		Amps	Volts		lbs	kgs
CD40-20/30-12/32-N2	2	10-30	12-32	05	10	4.5
CD40-20/30-12/32-N3	3	10-30	12-32	05	11	5.0
CD40-40/60-12/32-N2	2	40-60	12-32	1	14	6.4
CD40-40/60-12/32-N3	3	40-60	12-32	1	15	6.8
CD40-75/100-12/32-N2	2	75-100	12-32	2	23	10.4
CD40-75/100-12/32-N3	3	75-100	12-32	2	25	11.3

Note: All above models are configured for Negative Common. For Positive Common, part number changes as follows: CD40-20/30-12/32-P2.

Optional Internal Charge Dividers

- 100 To charge 2 batteries with a negative common
- 10U To charge 2 batteries with a positive common
- 101 To charge 3 batteries with a negative common
- 10V To charge 3 batteries with a positive common

Note: Consult factory may increase case size.

Battery Charger Sizing Guidelines

- Required Battery Backup Time (Hours)
- DC Output Voltage
- Ampere Hour Capacity of Battery
- Allowable Recharge Time From Full Discharge (Hours), Where Applicable
- Continuous and Intermittent DC Loads (Amps) and Duration (Time)

Ordering Information When ordering, please specify:

- La Marche Model Number A40 or A40F
- DC Amps
- DC Volts
- Special Frequency, When Required
- AC Voltage Code
- AC Phase Code
- Battery Cell Type Code
- Optional Accessories (Option Code)



Model Shown: A18J-3-12V-A1

Automatic Battery Chargers for Engine Starting Batteries

The La Marche models A18J and A20R Battery Chargers are completely automatic and are designed for continuous operation on unloaded Engine Starting Batteries. They are intended for mounting near the Engine Generator Set and to be permanently connected to the battery and AC lines.

The A18J and A20R Battery Chargers are simple to operate. There are no external controls or adjustments to be made once the battery is permanently connected. The models are available with either 120, 208 or 240VAC single phase input.

All models are equipped with convenient AC input taps to adjust the output voltage where low or high level AC lines are present.

Standard Features

- Silicon diode full wave rectifier design
- Automatic operation
- AC input fusing and DC output auto-reset breaker protects battery and charger
- Automatic surge protector
- Flush mounted 5% accuracy analog DC ammeter
- AC input voltages of 120, 208 or 240VAC, 50/60Hz, single phase
- No RFI (Radio Frequency Interference) emitted
- Simple operation - no external controls, switches or moving parts
- Charger design prevents battery from discharging if AC line fails
- Complete isolation of the AC line from the DC charging circuit eliminates the danger of high voltage shock to personnel on ungrounded equipment
- CSA Approved
- 2-Year Warranty

Optional Feature

- 03A - DC cranking disconnect relay

TABLE OF CONTENTS

Model Number	DC Output				AC Input Current Draw @ 100% (Load)			Cable Entry (When Facing Unit)		Overall Dimensions W x D x H	Mounting	Case No.	Shipping Weight	
	Amps	Volts	Battery Cells (Lead Acid)	Breaker Size	A 120	D 208	B 240	AC Input	DC Output				lbs	kg
A18J-2-6V	2	6	3	4	1			Bottom Front		5.125" x 7.125" x 11.250" 130 x 181 x 286mm	Wall	02	13	5.9
A18J-3-12V	3	12	6	5									13	5.9
A20R-4-24V	4	24	12	6	2	1	1	Bottom Front		5.125" x 7.125" x 11.250" 130 x 181 x 286mm	Wall	02	15	6.8
A20R-5-24/32V	5	24/30/32	12/15/16										16	7.3
A20R-5-30/36V		30/32/36	15/16/18										16	7.3

No. 02 Case Drawing

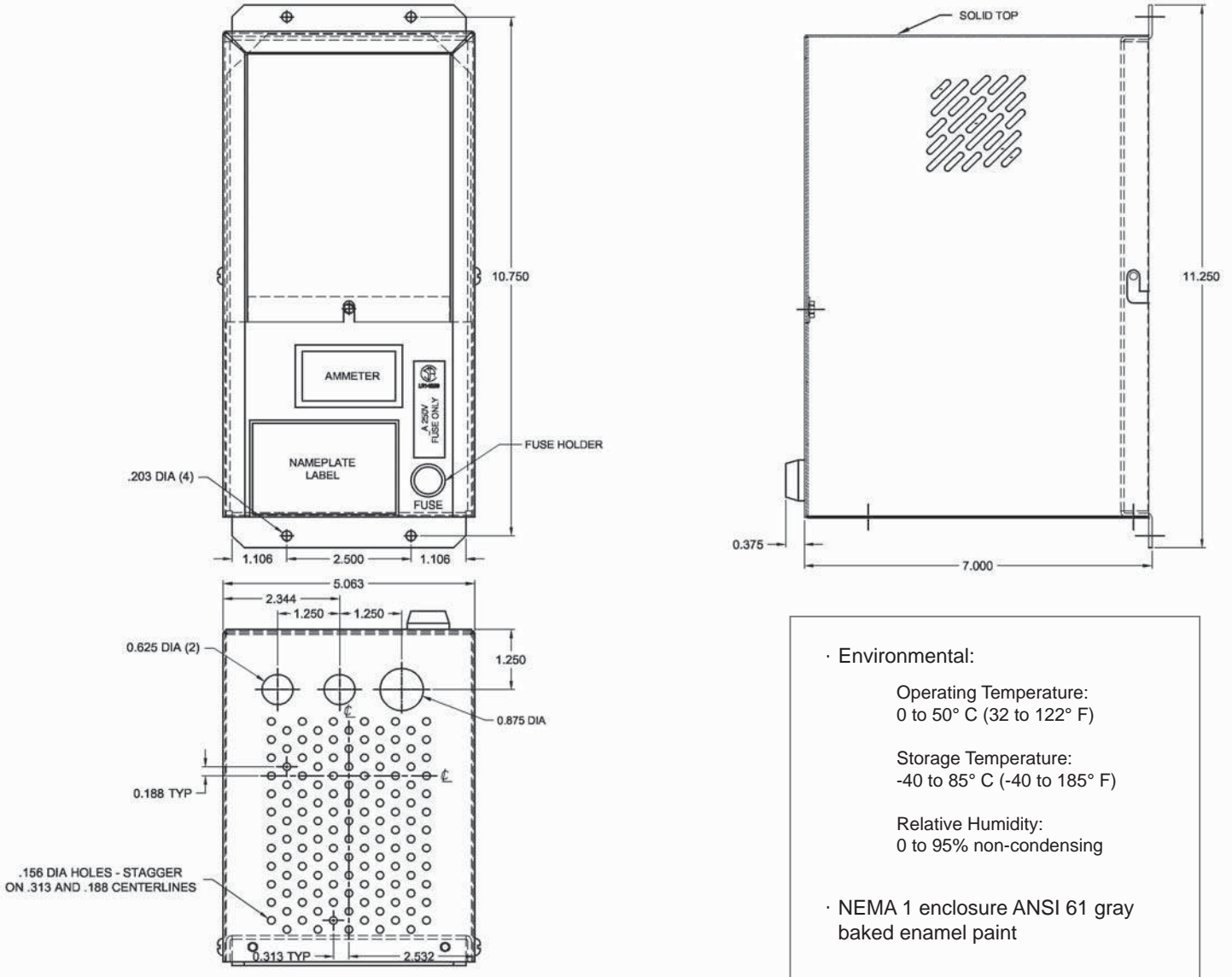

- Environmental:
 - Operating Temperature: 0 to 50° C (32 to 122° F)
 - Storage Temperature: -40 to 85° C (-40 to 185° F)
 - Relative Humidity: 0 to 95% non-condensing
- NEMA 1 enclosure ANSI 61 gray baked enamel paint

Model Number Nomenclature

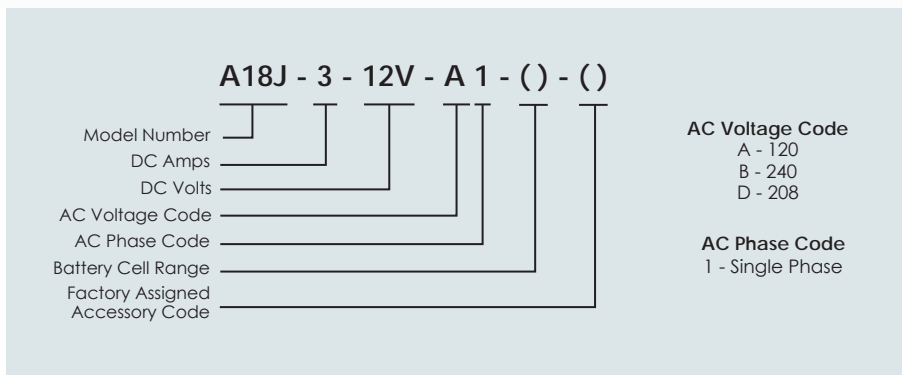

Ordering Information

When ordering, please specify:

- La Marche Model Number A18J or A20R
- Input Voltage
- Number of Battery Cells
- A.H. Capacity of Battery
- Allowable Recharge Time from Full Discharge (where applicable)
- Optional Accessory (Option #03A Cranking Disconnect Relay if desired)



The Industry's Most Reliable Filtered Battery Charger / Power Supply



Standard



16 Series CAP
W/Breakers



46 Series CAP
W/Breakers



The La Marche model A12B Series Filtered Battery Chargers / Power Supplies are engineered for the demanding requirements of SwitchGear applications, Process Controls and Communications. The magnetic amplifier circuitry is designed to carry continuous and intermittent loads up to the maximum rated output. Its robust design and unmatched reliability has made this workhorse the standard in the industry and with its customizing features.

Refer to Digital C.A.P. System Data Sheet for complete details.

Standard Features

- Magnetic Amplifier Circuitry
- Separate Float and Equalize Potentiometers provide simple and precise DC Voltage calibration
- Float/Equalize Mode Switching
- Float and Equalize Lights
- Automatic AC Voltage Compensation
- +/- 0.5% DC Voltage Regulation
- Fused AC input and DC output protects Battery and Charger/Power Supply
- Analog DC Ammeter and DC Voltmeter
- Current Limiting Circuitry prevents overload and provides current control from 50 to 120% of rated output (factory set at 115%)
- Output Filtered (With or Without a Battery) - 30mV RMS for Single Phase Models and 100mV RMS for Three Phase Models
- AC Power Failure Relay with Form "C" Contacts
- AC Surge Suppression (MOV)
- NEMA Type 1 Enclosure / IP20
- UL 1012 & C-UL Listed (UL 1481 Listing available)
- 10-year Limited Warranty



Specifications

ELECTRICAL

- **AC Input Voltages**
Single Phase 60Hz: 120, 208, 220, 240, 480 or 600
Single Phase 50Hz: 220/240, 380 or 415
Three Phase 60Hz: 208, 240, 480 or 600
Three Phase 50Hz: 220/240, 380 or 415
Voltage range: +/- 10% from nominal
Frequency range: +/- 5%
- **Power Protection**
AC Fuse, DC Fuse and Current Limit Protection
- **DC Output Amps and Voltages**
DC Amps: 3 to 400 amperes
DC Volts: 12, 24, 48, 130VDC (Others available such as 32, 36 & 260VDC)
- **Output Filtering (With or without a battery)**
30mV RMS for single phase models and
100mV RMS for three phase models
- **DC Voltage Regulation**
Plus or minus 0.5% of setting from no load to full load over the specified input voltage, frequency and ambient temperature ranges.

ENVIRONMENTAL

- **Operating Temperature**
0° to 50°C (32° to 122°F)
- **Storage Temperature**
-40° to 85°C (-40° to 185°F)
- **Relative Humidity**
0 to 95% (non-condensing)
- **MTBF**
Exceeds 250,000 Hours
- **Dimensions**
Overall dimensions and weights are listed on the last page of this Data Sheet. Case specifications are subject to change due to innovative product development and design. When space requirements are critical, please consult the factory.
- **Mounting**
Floor or wall units are available. Mounting flanges are supplied as integral part of cabinet back plate on wall mounted models.
- **Finish**
Pretreated with a seven stage iron phosphate wash, sealer and deionized rinse. Then coated with an environmentally safe and durable ANSI 61 gray Polyester TGIC Minitel powder finish.

AGENCY APPROVALS

- **UL Battery Charger**
File E 319318, Guide BBML
UL Std. No. 1012
- **C-UL Battery Charger**
CAN/CSA
Std. C22.2 No. 107-2
- **UL Fire Alarm System Power Supply**
File S2768, Guide UTRZ
UL Std. No. 1481
Must Specify Accessory Code 09A
24V output, 240V or less, 60Hz single phase input only.

Notes:
All models where appropriate will carry the U.L. and C-U.L. Battery Charger listing. When U.L. Fire Alarm System Power Supply Listings are required, you must specify this requirement at the time of order. Not all models can be U.L. approved. Accessories, type of charger and rating will determine U.L. approval. Consult our factory if U.L. approvals are required.

Optional Accessories

ALARM & CONTROL

- **16 Series** (Refer to Digital C.A.P. Systems Data Sheet for complete details)
LED C.A.P. Systems common features:
Selectable Display, Multi-Mode Equalize Timer
Equalize Light
AC Power Failure Relay w/ (2) sets Form "C"
Low DC Current Alarm w/ (2) sets Form "C"
Low DC Voltage 1 Alarm w/ (2)sets Form "C" & Adjustable Time Delay (0-255 sec) (Except Ground Detection Alarms).
Multi-Mode Equalize Timer with Light adjustable from 1-144 hrs with five selectable modes and various failure alarm & lights.
- **46 Series** (Refer to Digital C.A.P. Systems Data Sheet for complete details)
2 Line LCD C.A.P. Systems common features:
Selectable Display, Multi-Mode Equalize Timer
Equalize Light
Float Light
AC Power Failure Relay w/ (2) sets Form "C" (Except 46Q)
Low DC Current Alarm w/ (2) sets Form "C"
Low DC Voltage 1 Alarm w/ (2)sets Form "C" & Adjustable Time Delay (0-255 sec) (Except Ground Detection Alarms).
Multi-Mode Equalize Timer with Light adjustable from 1-144 hrs with five selectable modes and various failure alarm & lights.
Discrete Alarm LEDs (46A & 46B) Available
- **46A** Discrete Alarm LEDs (with Ground Detection)
For use with CAP systems 46J, 46U, 46Q, 46T
- **46B** Discrete Alarm LEDs (w/o Ground Detection)
For use with CAP systems 46E, 46P, 46G, 46L
- **03N** Low DC Current Alarm & Light w/ (1) set Form "C" contacts
- **04J** Electronic Equalize Timer Multi-Mode adjustable from 2-144hrs with five selectable modes; Standard, 7-day, 14-day, 30-day and Equalize after Low DC Voltage.
- **050** Ground Detection Switch 3-position with DC Voltmeter indication (130VDC models utilizes two switches)
- **051** Ground Detection Alarm with Reset Pushbutton and (1) set form "C" Positive and (1) set form "C" Negative contacts
- **052** Ground Detection Lights (Positive and Negative)
- **053** Ground Detection Switch & Lights (130VDC models utilizes two switches)
- **054** AC Power Failure Light
- **16C** Hi/Lo-2 Combination Alarm High/Low DC Voltage, Field Calibrations & Adjustments, Individual Lights and (2) Form "C" contacts for each alarm
- **10G** Forced Load Sharing (with same model number only)
- **103** Remote Sensing
- **20Q** Equalize Fan Control Relay

METERING & PROTECTION

- **011** AC Breaker Single Pole (120VAC only)
- **012** DC Breaker Single Pole
- **016** AC Breaker Two Pole

METERING & PROTECTION CONTINUED

- **017** DC Breaker Two Pole
- **01B** AC Breaker Three Pole (3-phase input only)
- **01M** DC Breaker two Pole High Interrupting - 22KAIC (up to 250VDC)
- **01C** AC Breaker two Pole High Interrupting - 65/35/18KAIC (240/480/600VAC)
- **01D** AC Breaker two Pole High Interrupting - 100/65/25KAIC (240/480/600VAC)
- **01F** AC Breaker three Pole High Interrupting - 65/35/18 KAIC (240/480/600VAC)
- **01G** AC Breaker three Pole High Interrupting - 100/65/25KAIC (240/480/600VAC)
- **06G** Zero Center Ammeter w/Battery & Load Terminals (under 250A units)
- **06L** AC Ammeter +/-2% accuracy (single phase)
- **06M** AC Voltmeter +/-2% accuracy (single phase)
- **14V** AC Voltmeter with switch (three phase)
- **14W** AC Ammeter with switch (three phase)
- **102** DC Blocking Diode
- **107** DC Surge Protectors (MOV's)
- **11L** Lightning Arrestor
- **217** Reverse polarity Protection & LED

MISCELLANEOUS

- **09A** UL1481 (24V output, 240V or less, 60Hz single phase)
- **092** Tropicalization (magnetics only) Single Phase
- **093** Tropicalization (magnetics only) Three Phase
- **10B** USCG (U.S. Coast Guard) Accessories
- **10L** Battery & Load Terminals (under 250A units)
- **11F** 30mV Filtering for 3-phase units
- **38G** ABS (American Bureau of Shipping) Modifications
- **38J** ABS (38G) & USGC (10B) Single Phase
- **38K** ABS (38G) & USGC (10B) Three Phase
- **11V** Temperature Compensation (Internal Probe)
- **11W** External Temperature Probe 22 ft
- **38D** Copper Ground Bus Bar
- **095** Heat Shrinkable Wire Markers with Point to Point Wiring Diagram
- **09W** Heat Shrinkable Wire Markers with Electrical Schematic
- **09L** Physical Parts Location Drawing
- **097** SIS Wire (#16 AWG and larger) Markers
- **080** Drip Shield (must order separately)
- --- Floor Stand (must order separately)
- --- Special NEMA (3R, 4, 4X and 12) and IP Rated Enclosures

COMMUNICATION PROTOCOLS (Offered only with 46 series C.A.P.)

- **21J** IEC 61850 Ethernet
- **21P** DNP 3.0 Communications RS232/RS485/Ethernet
- **21Q** MODBUS Communications RS232/RS485/Ethernet
- **21S** MODBUS RTU Serial Data Port
- **21X** SNMP

Notes: Discrete Alarms are not available in conjunction with Digital C.A.P. (Combined Accessory Package) systems. Typically, when ordering two or more discrete components, the Digital C.A.P. system listed above provides a more economical approach.
Case sizes may differ depending on optional accessories and/or 50Hz input. Please consult factory when dimensions are critical.

TABLE OF CONTENTS

Please consult factory for other available cell ranges if desired range not shown.

Must specify only one battery type and number of cells from range shown above.

	Model Number	DC Amps	DC Fuse Size (Amps) ⁽¹⁾	AC Input Phase	AC Input Current Draw @ 100% Load (Amps) ⁽²⁾									Std. Case Size ⁽⁴⁾	Shipping Weight (Approximate)	
					60Hz Units					50Hz Units					lbs	kgs
					A 120	D 208	L 220	B 240	C 480	ZD 600	B 240 / L 220	G 380	J 415			
12 volt systems (6L, 9 or 10NC)	A12B-3-12V	3	10	1	0.8	0.4	0.4	0.4	---	---	0.4 / 0.4	---	---	7	60	28
	A12B-6-12V	6	15	1	1.5	0.9	0.8	0.8	---	---	0.8 / 0.8	---	---	7	70	32
	A12B-10-12V	10	20	1	2.5	1.4	1.4	1.3	---	---	1.3 / 1.4	---	---	7	80	37
	A12B-15-12V	15	25	1	3.8	2.2	2.1	1.9	---	---	1.9 / 2.1	---	---	3	90	41
	A12B-20-12V	20	30	1	5	2.9	2.7	2.5	---	---	2.5 / 2.7	---	---	3	95	44
	A12B-30-12V	30	40	1	7.5	4.3	4.1	3.8	1.9*	1.6*	3.8 / 4.1	2.4*	2.2*	3	105	48
	A12B-40-12V	40	60	1	10	5.8	5.5	5	2.5*	2.1*	5 / 5.5	3.2*	2.9*	6	155	71
	A12B-50-12V	50	80	1	13	7.2	6.8	6.3	3.1*	2.6*	6.3 / 6.8	4.0*	3.6*	6	170	78
	A12B-60-12V	60	80	1	15	8.7	8.2	7.5	3.8*	3.1*	7.5 / 8.2	4.7*	4.3*	6	180	82
	A12B-75-12V	75	100	1	19	11	11	9.4	4.7*	3.9*	9.4 / 11	5.9*	5.4*	6	225	103
A12B-100-12V	100	150	1	25	14	14	13	6.3*	5.2*	13 / 14	7.9	7.2	8A	315	143	
	100	150	3	---	7.5	7.1	6.5	3.3*	2.7*	6.5 / 7.1	4.1*	3.8*	8A	325	148	
24 volt systems (12L, 18, 19 or 20NC)	A12B-3-24V	3	10	1	1.5	0.9	0.8	0.8	---	---	0.8 / 0.8	---	---	7	70	32
	A12B-6-24V	6	15	1	3	1.7	1.6	1.5	---	---	1.5 / 1.6	---	---	3	85	39
	A12B-10-24V	10	20	1	5	2.9	2.7	2.5	---	---	2.5 / 2.7	---	---	3	95	44
	A12B-15-24V	15	25	1	7.5	4.3	4.1	3.8	1.9*	1.6*	3.8 / 4.1	2.4*	2.2*	3	100	46
	A12B-20-24V	20	30	1	10	5.8	5.5	5	2.5*	2.1*	5 / 5.1	3.2*	2.9*	3	120	55
	A12B-25-24V	25	35	1	13	7.2	6.8	6.3	3.1*	2.6*	6.3 / 6.8	4.0*	3.6*	3	135	62
	A12B-30-24V	30	40	1	15	8.7	8.2	7.5	3.8*	3.1*	7.5 / 8.2	4.7*	4.3*	3	145	66
	A12B-35-24V	35	50	1	18	11	9.6	8.8	4.4*	3.7*	8.8 / 9.6	5.5*	5.1*	6	190	87
	A12B-40-24V	40	60	1	21	12	11	10	5*	3.2*	10 / 11	6.3*	5.8*	6	205	93
	A12B-50-24V	50	80	1	26	15	14	13	6.3*	5.2*	13 / 14	7.9	7.2	6	240	109
	A12B-60-24V	60	80	1	31	18	17	15	7.5	6.3*	15 / 17	9.5	8.7	6	265	121
	A12B-75-24V	75	100	1	38	22	21	19	9.4	7.8	19 / 21	12	11	70	400	182
	A12B-100-24V	100	150	1	51	29	28	26	13	11	26 / 28	16	15	70	450	205
		100	150	3	---	16	15	13	7	6	13 / 15	8.5	8	70	500	227
	A12B-125-24V	125	200	3	---	19	18	17	8.1	6.8*	17 / 18	11	9.4	70	525	239
A12B-150-24V	150	200	3	---	23	22	20	9.8	8.2	20 / 22	13	12	72	630	286	
A12B-200-24V	200	250	3	---	30	29	26	13	11	26 / 29	17	16	27	825	375	
A12B-250-24V	250	300	3	---	38	36	33	17	14	33 / 36	21	19	27	880	400	
A12B-300-24V	300	400	3	---	46	43	40	20	17	40 / 43	25	23	27	940	427	
A12B-400-24V	400	600	3	---	61	57	53	26	22	53 / 57	33	31	47	1350	613	
48 volt systems (24L, 36, 37 or 38NC)	A12B-3-48V	3	10	1	3	1.7	1.6	1.5	---	---	1.5 / 1.6	---	---	7	85	39
	A12B-6-48V	6	15	1	6	3.5	3.3	3	---	---	3 / 3.3	---	---	3	90	41
	A12B-10-48V	10	20	1	10	5.8	5.5	5	2.5*	2.1*	5 / 5.5	3.2*	2.9*	3	140	64
	A12B-15-48V	15	25	1	15	8.7	8.2	7.5	3.8*	3.1*	7.5 / 8.2	4.7*	4.3*	3	180	82
	A12B-20-48V	20	30	1	21	12	11	10	5*	4.2*	10 / 11	6.3*	5.8*	6	205	93
	A12B-25-48V	25	35	1	26	15	14	13	6.3*	5.2*	13 / 14	7.9	7.2	6	240	109
	A12B-30-48V	30	40	1	31	18	17	15	7.5	6.3*	15 / 17	9.5	8.7	6	265	121
	A12B-40-48V	40	60	1	41	24	22	21	10	8.4	21 / 22	13	12	6	275	125
	A12B-50-48V	50	80	1	51	29	28	26	13	11	26 / 28	16	15	8A	355	161
	A12B-60-48V	60	80	3	---	18	17	16	7.8	6.5*	16 / 17	9.9	9	8A	400	182
	A12B-75-48V	75	100	3	---	23	22	20	9.8	8.2	20 / 22	13	12	72	525	239
	A12B-100-48V	100	150	3	---	30	29	26	13	11	26 / 29	17	16	72	625	284
	A12B-125-48V	125	200	3	---	38	36	33	17	14	33 / 36	21	19	72	700	318
	A12B-150-48V	150	200	3	---	46	43	40	20	17	40 / 43	25	23	27	850	386
	A12B-175-48V	175	250	3	---	53	50	46	23	19	46 / 50	29	27	27	1000	454
A12B-200-48V	200	250	3	---	61	57	53	26	22	53 / 57	33	31	27	1150	522	
A12B-250-48V	250	300	3	---	76	71	66	33	28	66 / 71	42	38	47	1400	635	
A12B-300-48V	300	400	3	---	91	86	79	40	33	79 / 86	50	46	47	1700	772	
A12B-400-48V	400	600	3	---	121	114	105	53	44	105 / 114	66	61	47	1800	817	
130 volt systems (54 through 60L, 92 through 97NC)	A12B-3-130V	3	10	1	7.5	4.3	4.1	3.8	---	---	3.8 / 4.1	---	---	3	140	64
	A12B-6-130V	6	15	1	15	8.7	8.2	7.5	---	---	7.5 / 8.2	4.7*	---	3	140	64
	A12B-10-130V	10	20	1	26	15	14	13	6.3*	5.2*	13 / 14	7.9	7.2	6	225	103
	A12B-15-130V	15	25	1	38	22	21	19	9.4	7.8	19 / 21	12	11	6	250	114
	A12B-20-130V	20	30	1	51	29	28	26	13	11	26 / 28	16	15	6	270	123
		20	30	3	---	15	14	13	6.5	10	13 / 14	8.2	7.5	8A	360	164
	A12B-25-130V	25	35	1	63	37	35	32	16	14	32 / 35	20	19	8A	355	161
		25	35	3	---	19	18	16	8.1	13	16 / 18	10	9.4	8A	390	177
	A12B-30-130V	30	40	1	75	44	41	38	19	16	38 / 41	24	22	8A	390	177
		30	40	3	---	23	21	20	9.8	16	20 / 21	12	11	8A	430	196
	A12B-35-130V	35	50	1	88	51	48	44	22	19	44 / 48	28	26	72	505	230
		35	50	3	---	27	25	23	12	9.5	23 / 25	15	14	72	580	264
	A12B-40-130V	40	60	1	101	58	55	51	26	21	51 / 55	32	29	72	550	250
		40	60	3	---	30	29	26	13	11	26 / 29	17	16	72	625	284
	A12B-50-130V	50	80	3	---	38	36	33	17	14	33 / 36	21	19	72	645	293
	A12B-60-130V	60	80	3	---	46	43	40	20	17	40 / 43	25	23	27	865	393
	A12B-75-130V	75	100	3	---	57	54	49	25	21	49 / 54	31	29	27	930	422
	A12B-100-130V	100	150	3	---	76	71	66	33	28	66 / 71	42	38	27	1040	472
	A12B-125-130V	125	200	3	---	94	89	82	41	34	82 / 89	52	48	47	1500	681
	A12B-150-130V	150	200	3	---	113	107	98	49	41	98 / 107	62	57	47	1800	817
A12B-175-130V	175	250	3	---	132	125	114	57	48	114 / 125	72	66	47	1950	885	
A12B-200-130V	200	250	3	---	151	142	131	66	55	131 / 142	83	76	47	2100	953	
A12B-250-130V	250	300	3	---	188	178	163	82	68	163 / 178	103	95	47	2300	1044	
A12B-300-130V ⁽³⁾	300	400	3	---	226	214	196	98	82	196 / 214	124	113	47B	2400	1089	
A12B-400-130V ⁽³⁾	400	600	3	---	301	285	261	131	109	261 / 285	165	151	57	2550	1157	

⁽¹⁾ Optional DC Breaker when ordered in lieu of standard fuse(s) may slightly differ in ratings. AC Draws shown with asterisk * when equipped with AC Breaker, a series fuse is included.

⁽²⁾ AC Current Draws based @ 100% load and standard battery cells of 6L (12V), 12L (24V), 24L (48V) and 60L (130V). Maximum Current Draw is 120% of ratings shown. AC Current draws shown in Italics have high current draws for their specific input voltages - verification of input power requirement should be done prior to ordering. ⁽³⁾ Denotes units not UL Listed

⁽⁴⁾ Case sizes shown are for standard 60Hz units and may differ depending on optional accessories and/or 50Hz input. Please consult factory when dimensions are critical.

TABLE OF CONTENTS

Case Specifications

Case No.	Overall Dimensions						Cable Entry (when facing unit)		
	Width		Depth		Height		AC input	DC output	Mounting
	in	mm	in	mm	in	mm			
3	15.375	391	11.000	279	23.750	603	RIGHT	LEFT	WALL / FLOOR
6	25.580	650	13.935	354	28.000	711	RIGHT / TOP / BOTTOM	LEFT / TOP / BOTTOM	WALL / FLOOR
7	14.250	362	10.625	270	19.875	505	RIGHT	LEFT	WALL / FLOOR
8A	27.200	691	15.250	387	32.500	826	RIGHT	LEFT	FLOOR
27	27.312	694	25.875	657	56.125	1426	TOP	TOP	FLOOR
47	38.000	965	39.375	1000	70.000	1778	TOP / BOTTOM	TOP / BOTTOM	FLOOR
47B	38.00	965	46.750	1188	71.125	1807	TOP / BOTTOM	TOP / BOTTOM	FLOOR
57	60.000	1524	36.000	914	80.000	2032	BOTTOM	BOTTOM	FLOOR
70	27.000	686	19.000	483	41.000	1041	RIGHT / BOTTOM	LEFT / BOTTOM	FLOOR
72	27.000	686	23.500	597	44.500	1130	RIGHT / BOTTOM	BOTTOM	FLOOR

Case sizes may differ depending on optional accessories and / or 50Hz input. Please consult factory when dimensions are critical. Dimensions shown above are overall footprint. Detailed dimensions drawings are available for mounting purposes.



46 Series (LCD)



16 Series (LED)

Refer to Digital C.A.P. System Data Sheet for complete details. Discrete alarm LEDs available.

Model Number Nomenclature

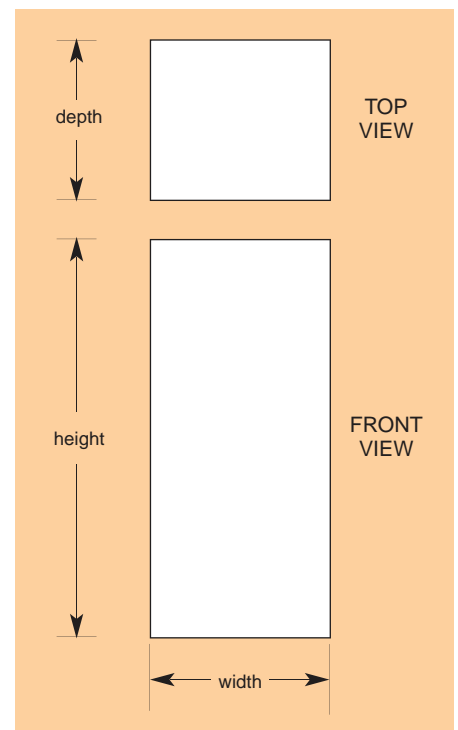
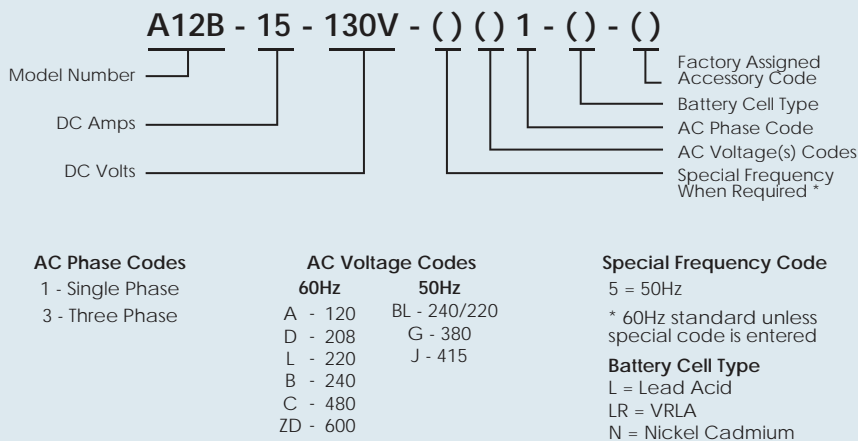

Ordering Information

When ordering, please specify:

- La Marche Model Number A12B
- Input Voltage, Frequency, Phase
- Number and Type of Battery Cells
- Amp Hour Capacity of Battery
- Intermittent DC Loads and Duration
- Continuous DC Load
- Allowable Recharge Time from Full Discharge (where applicable)
- Optional Accessories
- Verify AC Input Current Draw

DC Power Distribution Center



Unit Shown: LMDC-600-48V-1T-2-2

The LMDC (La Marche Distribution Center) is designed to work with LMHF rectifiers. It combines the load distribution breakers, current shunts, LVLD (Low Voltage Load Disconnect) ground and charge bus bars into one compact unit. The LMDC is offered in two configurations; a single breaker tier (row) configuration or two breaker tier configuration. The distribution breaker bus is rated at 600A per tier. Each breaker is equipped with 20 plug-in distribution breaker positions and contactor (LVLD) that is controlled by the LMHF controller. One tier of breakers may be setup with most the critical loads and the other with the less critical loads. This allows you to shed the load by eliminating the less critical and keeping the most critical loads running, thus conserving and extending your battery energy usage. To simplify the installation, this distribution center utilizes plug in type breakers.

Another advantage of this versatile product is that the main charge and ground bus are rated so that it can support up to three LMHF (48V) rectifier shelves or two (24V) rectifier shelves. This allows for easy expansion in case the rectifier capacity needs to be increased. All you need to do is add a second or third shelf without needing to resize the system main bus work.

Standard Features

- Front Customer Access
- Plug-In Breakers
- 23" Rack Mounting (Center)
- Two Controller Configurations (Built-In or External)
- Customer Alarm Interface (LMHF I/O For use with Shelf Mounted Controller)
- Available in 24V or 48V
- Top Cable Access
- LVLD Contactor (One Per Tier)
- LVLD Bypass Switch
- 6 RU for One Tier, 9 RU for Two Tier

TABLE OF CONTENTS

Model Number	Tiers	Breaker Positions	Overall Dimensions W x D x H	Mounting	RU's	Unpackaged
LMDC-600-48V-1T-1- 1	One	20	20.81" x 17.5" x 10.5" 219 x 689 x 413 mm	23"	6	56 lbs
LMDC-600-48V-1T-2- 2	One	20	20.81" x 17.5" x 10.5" 219 x 689 x 413 mm	23"	6	63 lbs
LMDC-1200-48V-2T-1- 3	Two	40	20.81" x 17.5" x 15.75" 219 x 689 x 597 mm	23"	9	95 lbs
LMDC-1200-48V-2T-2- 4	Two	40	20.81" x 17.5" x 15.75" 219 x 689 x 597 mm	23"	9	102 lbs
LMDC-600-24VN-1T-1- 5	One	20	20.81" x 17.5" x 10.5" 219 x 689 x 413 mm	23"	6	56 lbs
LMDC-600-24VN-1T-2- 6	One	20	20.81" x 17.5" x 10.5" 219 x 689 x 413 mm	23"	6	63 lbs
LMDC-1200-24VN-2T-1- 7	Two	40	20.81" x 17.5" x 15.75" 219 x 689 x 597 mm	23"	9	95 lbs
LMDC-1200-24VN-2T-2- 8	Two	40	20.81" x 17.5" x 15.75" 219 x 689 x 597 mm	23"	9	102 lbs

Breaker Kits:

Breaker Current Rating SP4K - LMDC - () B1

Available Breaker Current Ratings:
1A, 2A, 3A, 5A, 10A, 15A, 20A, 25A, 30A, 35A, 40A
50A, 60A, 70A, 80A, 100A, 125A, 150A, 200A

Breaker Positions Request:

1A - 100A = 1 Position
125A - 150A = 2 Positions
200A = 3 Positions



LMDC / LMHF Union Bus Kit

- LMDC-SB1-KIT use with One LMHF Shelf
- LMDC-SB2-KIT use with Two LMHF Shelves
- LMDC-SB3-KIT use with Three LMHF Shelves



Single tier LMDC with built in LMHF Controller



Two tier LMDC for use with shelf mounted LMHF Controller

Model Number Nomenclature

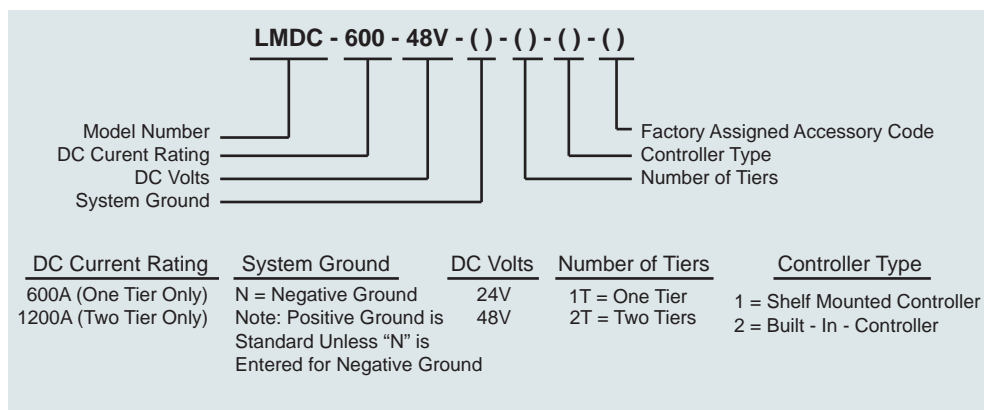

Ordering Information

When Ordering, Please Specify:

- La Marche Model Number LMDC
- DC Amps
- DC Volts
- System Ground
- Number of Tiers
- Controller Type
- Optional Breaker Kits



TELECOM POWER SYSTEM

LTP

DC POWER SYSTEM



Shown Above: LTP-30-48V w/communication option



The La Marche LTP system offers a complete DC power solution in a compact package configuration . LTP system can be installed in standard 19 inch or optional 23 inch rack or cabinet.

The LCD controller allows easy adjustments of output voltage, alarms and communication settings. This advanced controller supports distribution, alarm contacts, battery test, load current and battery charge current limit. The parallel operation nature of the rectifiers is ideal for N+1 redundant installation.

The compact design of the system uses high efficiency rectifiers to reduce space requirements and installation cost. The DC distribution can be comprised of either GMT fuses or output terminals.

Standard Features

High Frequency Switchmode Circuitry

Universal Input Range (102-264 VAC)

Power Factor > 0.99

Efficiency > 90%

Forced Load Sharing

Modular, Hot Pluggable Design

Four Module Positions

DC Distribution (GMT)

Battery Charge Control

Load and Battery Current Monitoring

Form "C" Dry Alarm Contacts

LED Status Indicators

LCD Display

19" Rack or Wall Mount

AC Cord

2 Year Warranty

Optional Accessories

21X SNMP Ethernet Module (VLAN Ready with Battery Testing)

20X 7 ft Twist Lock AC Cord (20Amp)

08X 23" Rack or Wall Mount Mounting Kit

57V DC Output Terminals (Bulk)

57W Battery Terminals



Rectifier



Controller



		Model Number	LTR-10-12V-U1	LTR-10-24V-U1	LTR-7.5-48V-U1
RECTIFIER		Input Voltage	102 - 264 VAC	102 - 264 VAC	102 - 264 VAC
		Input Current	1.5 / 0.7A	2.8 / 1.5A	3.8 / 2.3A
		Input Frequency	45 - 65 Hz	45 - 65 Hz	45 - 65 Hz
		Input Connections	Hot Pluggable	Hot Pluggable	Hot Pluggable
		Output Voltage	12V	24V	48V
		Output Current	10A	10A	7.5A
		Indicators	DC LED AC LED Alarm LED	DC LED AC LED Alarm LED	DC LED AC LED Alarm LED
		Power Factor	> .99	> .99	> .99
		THD	< 5%	< 5%	< 5%
		Efficiency	≥ 90%	≥ 90%	> 93%
		Load Regulation	< ±0.5%	< ±0.5%	< ±0.5%
		Line Regulation	< ±0.1%	< ±0.1%	< ±0.1%
		Noise	< 32 dBBrnC	< 32 dBBrnC	< 32 dBBrnC
		Protection	Fuse and blocking diode	Fuse and blocking diode	Fuse and blocking diode
		Temperature	Operating: 0° to 50°C (32° to 122° F) Storage: -40° to 85°C (-40° to 185° F)	Operating: 0° to 50°C (32° to 122° F) Storage: -40° to 85°C (-40° to 185° F)	Operating: 0° to 50°C (32° to 122° F) Storage: -40° to 85°C (-40° to 185° F)
		Relative Humidity	0 to 95% non-condensing	0 to 95% non-condensing	0 to 95% non-condensing
		Cooling	Fan Assisted	Fan Assisted	Fan Assisted
	Dimensions (H x W x D)	5.6" x 3.2" x 9.0" 142.2 x 81.3 x 228.6mm	5.6" x 3.2" x 9.0" 142.2 x 81.3 x 228.6mm	5.6" x 3.2" x 9.0" 142.2 x 81.3 x 228.6mm	
	Weight	4 lb (1.8kg)	4 lb (1.8kg)	4 lb (1.8kg)	
	Mounting	Shelf	Shelf	Shelf	
POWER SHELF	GENERAL	Capacity	Four slots to hold rectifiers		
		Dimension (H x W x D)	5.6" x 19" x 9.5" 442.24 x 482.6 x 241.3mm		
		Weight	7.5 lbs		
		Mounting	19" Rack Mount or Wall Optional 23" Rack Mounting Kit (Option 08X)		
		Connections	AC cable included (7ft locking type IEC 60320 C19EL) DC - Load and Battery connections are made via controller/distribution assembly RJ-45 - optional communications (web interface)		
	CONTROLLER/DISTRIBUTION	Display	2 x 16 Character LCD		
		Metering	DC Volts, Load Current, Battery Charging Current		
		Features	Separate Current Limits for Load and Battery Charge Battery Test (automatic and manual mode, accessible via settings menu) Adjustments via Settings Menu Alarms Integrated Load Distribution		
		Alarms	LCD Notifications & Form "C" Contacts for: AC Mains Failure, Distribution Fuse Open, Rectifier Failure, Low DC Volts Latching Audible Alarm for Automatic Battery Test with Enable/Disable Feature Battery Breaker Trip Alarm (shares relay with Low Voltage alarm with Enable/Disable feature)		
		Adjustments (via settings menu)	Output Voltage, Battery Charging Current, Alarms Enable/Disable		
		Distribution	Refer to page 3		
		OPTIONAL WEB INTERFACE	Supported Network Type	WAN, LAN, VLAN	
	Protocol		TCP/IP, SNMP		
	Server Based Monitoring Features		Monitoring of System Parameters and Alarms Remote Battery Test Device Naming Convention Compatible with Server Based Monitoring Provided by La Marche Mfg.		
	Server Based Monitoring Features (Optional service provided by La Marche)		Multiple System Management/Monitoring Email Notifications Configurable with SQL Data Base		

Controller/Distribution Options

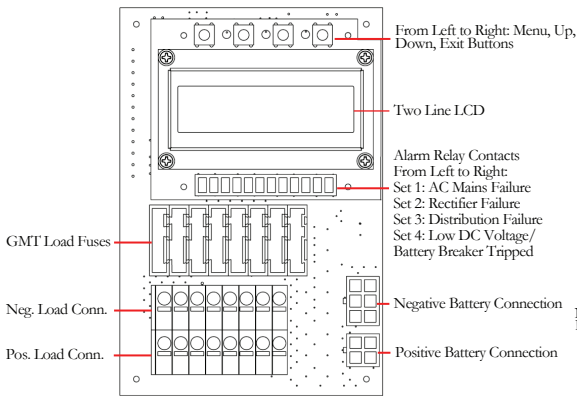

Standard
Controller with GMT Fuses
& Battery Box Connection

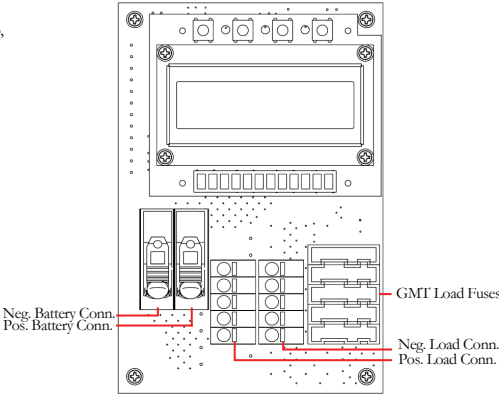

Option 57W
Controller with GMT Fuse
& Battery Connections

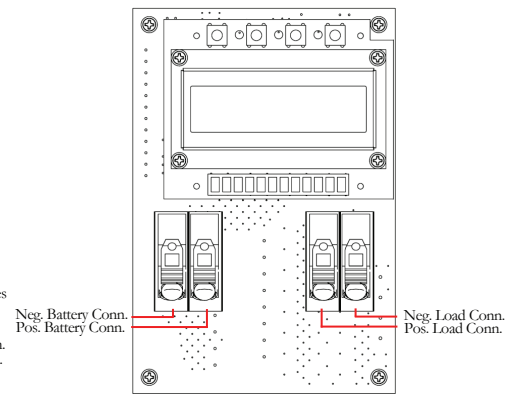

Option 57W & 57V
Controller with Load
& Battery Connections

LTP Block Diagram

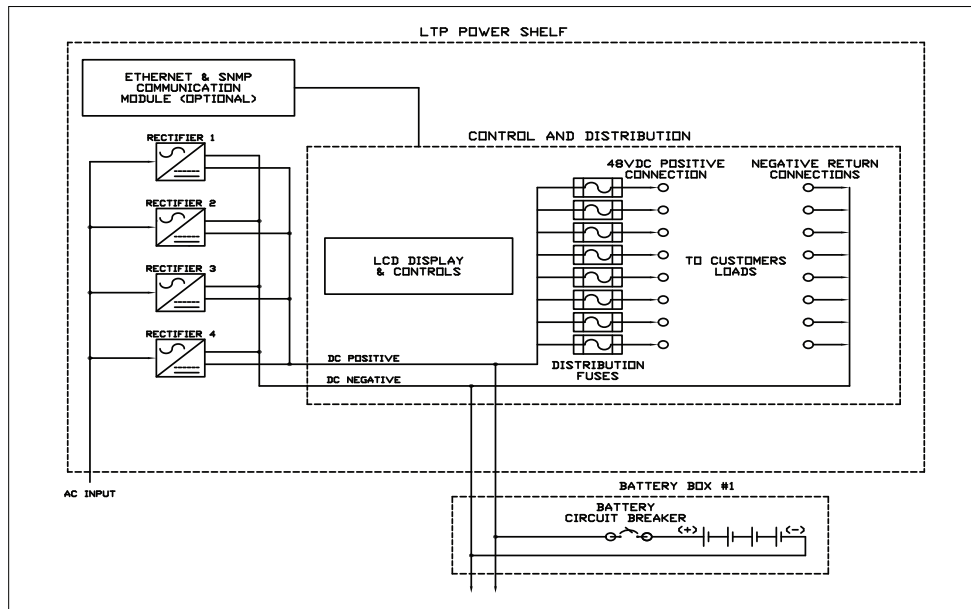

Fuse Information

When ordering, please specify

- Fuse Part Number: P8-K1-A (X)
X = Fuse Rating
- Available sizes:
0.25, 0.5, 1, 2, 3, 5, 10

Ordering Information

When ordering, please specify

- La Marche Model number
- DC Voltage
- Battery Amp Hour Rating
- Number & Type of Battery cells



Shown Above: LTPB-1-48V

Battery Box Standard Features

- Battery Breaker
- 19" Rack or Wall Mount
- Slots for up to four batteries
- NEMA 1
- Wiring for series or parallel configuration

	Model Number	Volts	AH Rating	Overall Dimensions	Battery Enclosure	Weight	
						lbs	kgs
Battery	P24B-12-12V	12 VDC	12 AH	3.9" x 3.9" x 6.0" 99.0 x 99.0 x 152.4 mm	LTPB-1	9.2	4.2
	P24B-18-12V	12 VDC	18 AH	6.6" x 3.0" x 7.13" 167.6 x 76.2 x 181.1 mm	LTPB-2	12.6	5.7
	P24B-26-12V	12 VDC	26 AH	4.9" x 6.9" x 6.5" 124.5 x 175.3 x 165.1 mm	LTPB-2	17.1	7.8
	P24B-35-12V	12 VDC	35 AH	6.2" x 5.2" x 7.8" 157.5 x 132.0 x 198.1 mm	LTPB-2	26	11.8

	Model Number	Output Nominal Voltage	Overall Dimensions H x W x D	Mounting	Shipping Weight	
					lbs	kgs
Battery Enclosure	LTPB-1-48V	48 VDC	5.6" x 19.0" x 8.8" 142.2 x 482.6 x 223.5 mm	4 RU	10	4.5
	LTPB-2-48V	48 VDC	8.7" x 19.0" x 19.0" 221.0 x 482.6 x 482.6 mm	5 RU*	22	10
	LTPB-1-24V	24 VDC	5.6" x 19.0" x 8.8" 142.2 x 482.6 x 223.5 mm	4 RU	10	4.5
	LTPB-2-24V	24 VDC	8.7" x 19.0" x 19.0" 221.0 x 482.6 x 482.6 mm	5 RU*	22	10
	LTPB-1-12V	12 VDC	5.6" x 19.0" x 8.8" 142.2 x 482.6 x 223.5 mm	4 RU	10	4.5
	LTPB-2-12V	12 VDC	8.7" x 19.0" x 19.0" 221.0 x 482.6 x 482.6 mm	5 RU*	22	10

* 5 RU - Horizontal rack-mount arrangement requires an additional bracket kit (SP3K-LTPB2-1)
Vertical rack-mount or wall-mount arrangement is 11 RU

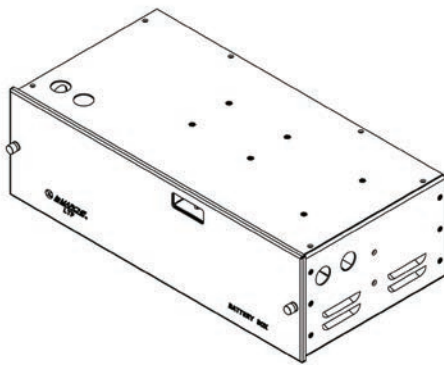

LTP Battery Box 1

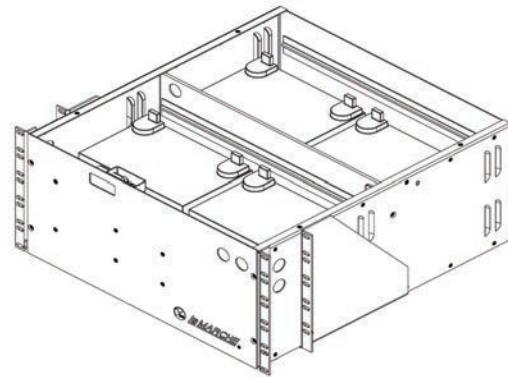

LTP Battery Box 2



800VA / 1kVA 2RU INVERTER



LTI2 front view



LTI2 back view

The La Marche LTI 2 inverter is the ideal choice when the AC power requirements are critical. This inverter is equipped with standard features such as sine wave output, voltage regulation, under/over-voltage conditions, and overload protection. The LTI 2 Inverter Series is designed to operate at 48VDC input and produce 120 VAC nominal output. The 60Hz output sine wave is produced using an advanced DSP controlled architecture which achieves 90% efficiency.

The La Marche LTI 2 inverter is compact, 19" rack mount in a 2RU configuration, designed for data centers, and telecommunications applications.

DC INPUT SPECIFICATIONS	800 VA	1 kVA
Nominal DC Voltage	48V (44-56V)	
Nominal Current	19A	24A
Efficiency	Up to 90%	
Connections	Terminal Block	
AC OUTPUT SPECIFICATIONS		
Nominal Output Power	800 VA	1,000 VA
Output Waveform	Pure Sine Wave	
Nominal Voltage	120 Vac	
Frequency	60 Hz	
Voltage Regulation	±1%	
Load Power Factor	0.8 to 1	
Connections	2 x NEMA - 5-15R Receptacle (rear) Terminal Block (rear)	
GENERAL SPECIFICATIONS		
Optional Accessories	21X -SNMP/Ethernet Communications	
DC to AC Isolation	Yes	
Status LEDs	Inv. On Battery Low Summary Alarm Fan Failure	
Alarm Contacts (Dry Contacts)	Inverter Fail Summary Alarm	
Protection	DC Input Breaker Low Input Voltage Shutdown w/ Auto Recovery High Input Voltage Shutdown Overload Shutdown Over Temperature Protection	
Operating Temperature	0° to 50°C (32° to 122°F)	
Storage Temperature	-40° to 85°C (-40° to 185°F)	
Dimensions (H x W x D)	3.5 x 17.1 x 14.6" (88.9 x 434.3 x 370.8 mm)	
Weight	15lb (6.8kg)	
Mounting	Rack 19"- 23"/ Wall Mounting	



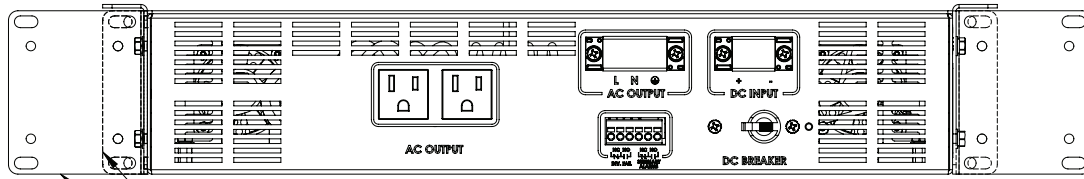

BRACKETS' ORIENTATION FOR 19" MOUNTING CONFIGURATION
 BRACKETS' ORIENTATION FOR 23" MOUNTING CONFIGURATION
 BACK VIEW

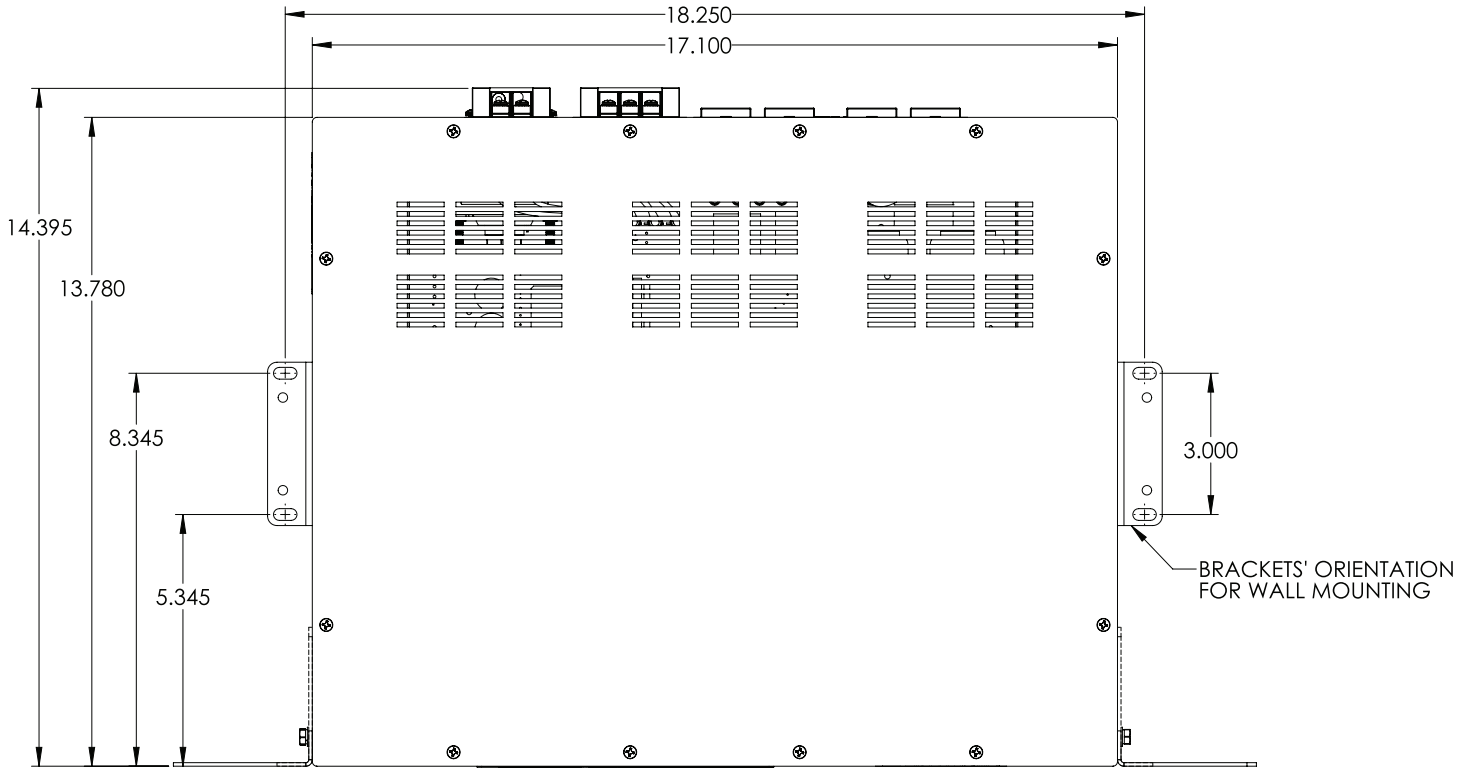

TOP VIEW

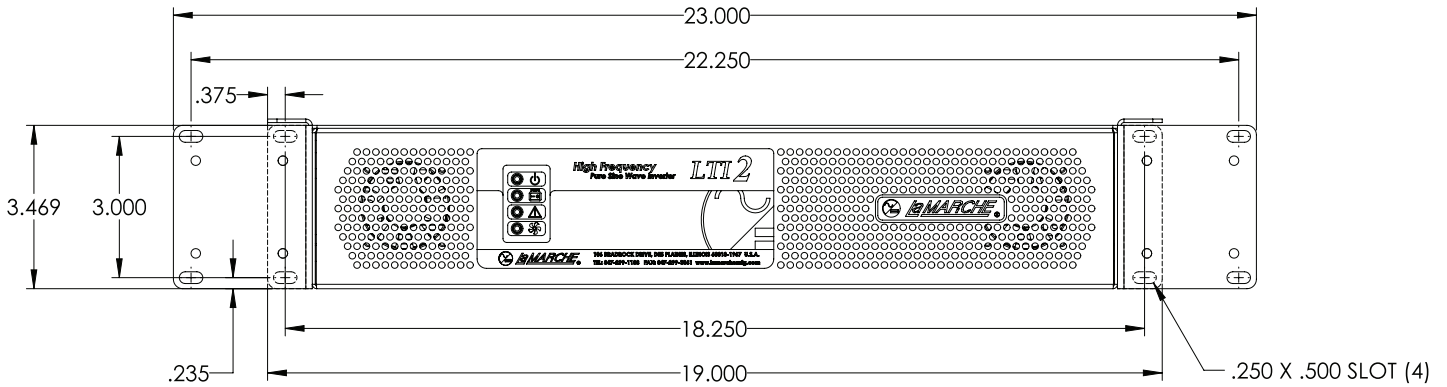

FRONT VIEW



Modular Switchmode Rectifier System



Unit Shown: LMHF-75-48V with Modules & Shelf



The La Marche model LMHF (La Marche High Frequency) is a 4 RU modular design rectifier for telecommunication applications. It is a highly compact self-contained power system. The current limiting circuitry, voltage regulation, high efficiency and high power factor makes the LMHF an ideal choice where power requirements are critical.

These rectifiers are available with nominal output voltages of 24 VDC or 48 VDC and can deliver 115 amps and 75 amps respectively. The nominal universal input range of 208 VAC to 277 VAC and the frequency range of 45 to 66 Hz provides the flexibility for worldwide power requirements.

The temperature controlled variable fan speed rectifier in a six across 23" rack configuration (five across in 19" configuration) offers high power density and efficiency. These parallel operating rectifiers are ideal for N+1 redundancy.

The system controller features data-logging, advanced alarm notification and full graphic LCD touch-screen. This user-friendly graphical (Menu Driven) display allows simple control and monitoring of LMHF rectifiers. Complete configurations and monitoring is possible through the Ethernet port and web browser. The communication ports provide reliable communication between LMHF power system and management system.

LMHF controller easily allows adjustments such as float voltage, equalize voltage, high voltage alarm, low voltage alarm and high voltage shutdown.

Standard Features

Rectifier

- High Frequency Switchmode Circuitry
- Power Factor Correction Circuitry
- Hot Swappable 4 RU Design
- Output Power
 - 4 KW per 48 Volt Rectifier
 - 3.1KW per 24 Volt Rectifier
- 95% Efficiency
- Parallel Operation
- Over Temperature and Over Voltage Protection
- Operating Temperature
 - 40° to 65°C (-40°to149°F)
- Indicators
 - AC ON - Green LED
 - DC ON - Green LED
 - Alarm - Red LED
- Backwards Compatible With LMHF 65-48V

Shelf

- 23" Rack Mounting - up to 6 Modules
(19" up to 5 Modules)
- Easy Installation and Maintenance

Controller

- Rack Mount
- LCD Touch-Screen Graphical Display for Local Set-Up, Adjustment and Control
- Digital and Analog User-Configurable Inputs
- Temperature Compensation (With Optional Probe)
- User-defined Major/Minor Alarms
- Web server and SNMP Support Via Ethernet
- Connectivity: Ethernet, RS232, RS485
- 2-Year Warranty

TABLE OF CONTENTS

	Model Number	AC Input			DC Output			Overall Dimensions H x W x D (inches)	Mounting	Shipping Weight	
		Nominal	Operating	Frequency	Amps	Volts (Nominal)	Range			lbs	kgs
Rectifier	LMHF-110-24V-D-F1	208-277 VAC	176-312 VAC	45-70 Hz	115	24	21-29 VDC	6.3" x 3.4" x 11.8"	4RU	10	4.6
	LMHF-75-48V-ZE1*	208-277 VAC	187-320 VAC	45-66 Hz	75	48	42-60 VDC	6.3" x 3.4" x 11.8"	4RU	10	4.6
Shelf	LMHF-PC660-24V-23*	208-277 VAC	176-312 VAC	45-70 Hz	660	24	21-29 VDC	6.9" x 20.8" x 15.3"	4RU	21	9.5
	LMHF-PC390-48V-23*	208-277 VAC	187-320 VAC	45-66 Hz	450	48	42-60 VDC	6.9" x 20.8" x 15.3"	4RU	21	9.5



Rectifier Specifications

INPUT VOLTAGE

- **Nominal:** 208 to 277 VAC
- **Operating:** 187 to 320 VAC @ 48V
176-312 @ 24V
- **Extended:** 90 to 187 VAC (derated power)

INPUT CURRENT

- 48 VDC 17.5A @ 240 VAC
21.5A @ 208 VAC
23.5A @ 176 VAC (Max)
- 24 VDC 14.6A @ 240 VAC
16.9A @ 208 VAC
20.2A @ 176 VAC (Max)

INPUT FREQUENCY

- 45 to 66Hz (48 VDC Models)
- 45 to 70Hz (24 VDC Models)

POWER

- 4000W @ 48 VDC
- 3100W @ 24 VDC

OUTPUT CURRENT

- 115A @ 27 VDC (130A max. 24V)
- 74A @ 54 VDC (83 max. 48V)

POWER FACTOR

- > 0.99 (50 to 100% load)

THD

- < 5%

EFFICIENCY

- 24V >90%
- 48V > 95%

LOAD REGULATION

- < ±0.5%

LINE REGULATION

- < ±0.1%

NOISE

- < 38dBmC

RIPPLE

- < 30mV RMS

PROTECTION

- Current Limit, High Voltage, Shutdown, Start Delay, Input/Output Fuses

WEIGHT

- 9lb (4kg)

ENVIRONMENTAL

TEMPERATURE

- **Standard:** -40° to 55°C (-40° to 149°F)
- **Storage:** -40° to 85°C (-40° to 185°F)

HUMIDITY

- 0 to 95% RH non-condensing

ELEVATION

- -500 to 4000m (-1640 to 13120ft)

HEAT DISSIPATION

- < 1150 BTU per hour

	Model Number	Input		Overall Dimensions H x W x D (inches)	Mounting		Shipping Weight (approx.)	
		Amps	Voltage		Shelf	Rack	lbs	kgs
Controller	LMHF-SSC-0-1	<200mA	20-60 VDC	6.9 x 2.9 x 10	4RU	-	3.9	1.8

* Backwards compatible with LMHF 65-48V

** 19" configuration available upon request, please contact factory for specifications.

Controllers are factory set @ 48V, to change the settings to 24V refer to the instruction manual.



Shelf Specifications

23" SHELF DIMENSIONS

- 6.9H x 20.8W x 15.3D (inches)
- 177H x 530W x 389D (mm)

WEIGHT

- 21lb (9.5kg)

MOUNTING

- Flush mount up to 6 modules

OPTIONAL REAR COVER

- LMHF-SRC-1

CONNECTIONS

INPUT (per rectifier)

- Box type terminal block 10 to 6AWG (6 to 16mm²)

OUTPUT

- Bus adapters with 3/8 studs

CHASSIS GROUND

- Compression lug (10 to 6AWG)

CAN COMMUNICATION

- RJ12 offset



Controller Specifications

DISPLAY

- LCD touch screen, 160 x 160 pixels

LED INDICATORS

- System OK, Minor and Major

PORTS

- RS232, RS485, Ethernet

MODEM

- Optional (consult factory)

INPUT VOLTAGE

- 20 to 60 VDC

CURRENT

- < 100mA @ 48V
- < 200mA @ 24V

TEMPERATURE

- -40° to 65°C

WEIGHT

- 3.9lb (1.8kg)
- 13.8 Shelf and Rack

ADJUSTMENTS

- Float Voltage, Equalize Voltage, High Voltage Alarm, Low Voltage Alarm, High Voltage Shutdown, Current Limit, Slope, Start Delay Timers

Agency Approvals

Safety: CSA C22.2 No 60950-1-03
UL 60950-1 1st Edition
CE marked
IEC/EN 60950-1
ANSI / IEEE C62.41 Cat B3

Ordering Information

When ordering, please specify:
- La Marche Model Number



Modular Power System -48V or +24V up to 1200A



The LMPS is specifically designed as an all in one solution that integrates our High Frequency rectifiers with our distribution center. It combines the load distribution breakers, LVLD, interface, ground/charge bars and High Frequency modular rectifiers into a 23" rack mount unit.

The LMPS is offered in two load configurations; a 600A single breaker tier configuration or 1200A two breaker tier configuration. The distribution breaker bus is rated at 600A per tier. Each breaker tier is equipped with 20 Plug-In distribution breaker positions and a contactor (LVLD) that is controlled by the systems' controller. The main bus bars are rated to support up to two 48V or two 24V rectifier shelves. Operating the hot-swappable rectifiers in parallel provides ideal N+1 redundancy, which allows for easy rectifier replacement without system interruption.

Standard Features

CONTROLLER

- LCD Touch-Screen Display
- Digital and Analog User-Configurable Alarms
- Temperature Compensation (With Optional Probe)
- User-defined Major/Minor Alarms
- Protocols: SNMP, Modbus

DISTRIBUTION AND TERMINATION

- Front access
- Single Pole Plug-In breakers (20 positions)
- 23" Rack mounting
- -48V or +24V
- Top cable access
- LVLD with bypass switch
- Customer alarm connections

SHELF

- 23" Rack Mounting - up to 6 Modules
- Easy Installation and Maintenance

RECTIFIER

- High Frequency Switchmode
- Power Factor Correction
- Hot Swappable
- Output Power
 - 4 KW per 48 Volt Rectifier
 - 3.1KW per 24 Volt Rectifier
- 95% Efficiency
- Parallel Operation
- Over Temperature/Voltage Protection
- Operating Temperature
 - 40°C to 55°C (-40°F to 149°F)
- Indicators
 - AC ON - Green LED
 - DC ON - Green LED
 - Alarm - Red LED
- 2 Year Warranty for the complete system



Specifications

ELECTRICAL

- **Input Voltage**
Nominal: 208 to 277 VAC
Operating: 187 to 320 VAC
- **Output Voltage DC**
-48 VDC or +24 VDC
- **Max Bus Capacity**
1200A (2 Tier), 600A (1 Tier)

DISTRIBUTION AND TERMINATION

- **Tier 1**
Up to 20 Plug in Load Breaker Positions
One LVLDC Contactor
Maximum Number of Rectifiers: 6
- **Tier 2**
Up to 40 Plug in Load Breaker Positions
Two LVLDC Contactor
Maximum Number of Rectifiers: 12

CONTROLS AND COMMUNICATIONS

- **Display**
Touch Screen LCD Display
- **LED Indicators**
System OK, Minor & Major
- **Analog user Configurable Inputs**
- **Digital Input Channels**
Four Channels
- **8 Form "C" Contacts**
- **Event Log and Statistics**
- **Connectivity via Ethernet, RS232, RS485**
- **Adjustments**
Float Voltage High Voltage Shutdown
Equalize Voltage Current Limit
High Voltage Alarm Temp. Compensation Slope
Low Voltage Alarm Start Delay Timer

OPERATIONAL AND ENVIRONMENTAL

- **Efficiency**
95%
- **Power Factor**
> 0.99 (50 to 100% load)
- **Load Regulation**
± 0.5%
- **Line Regulation**
± 0.5%
- **Temperature Range**
Standard: -40°C to 55°C
Storage: -40°C to 85°C
- **Humidity**
0 to 95%
- **Elevation**
-500 m to 4,000 m (-1,640 ft to 13,123 ft)
- **Heat Dissipation**
< 1150 BTU per Rectifier

Model Number	AC Input		DC Output		Distribution Tiers (T)	Power Shelf (S)	Breaker Positions	RUs	Overall Dimensions H x W x D	Overall Weight*	
	Nominal	Frequency	Amps	Volts (Nominal)						lbs	kgs
LMPS-600-24VN-1T1S-XR	208-277 VAC	45-70 Hz	690	24 VDC	1	1	20	10	17.5 x 20.8 x 17.5 in 444.5 x 528.3 x 444.5 mm	84	38
LMPS-600-48V-1T1S-XR	208-277 VAC	45-66 Hz	450	48 VDC	1	1	20	10	17.5 x 20.8 x 17.5 in 444.5 x 528.3 x 444.5 mm	84	38
LMPS-1200-24VN-2T2S-XR	208-277 VAC	45-70 Hz	1380	24 VDC	2	2	40	17	29.55 x 20.8 x 17.5 in 750.6 x 528.3 x 444.5 mm	144	65
LMPS-1200-48V-2T2S-XR	208-277 VAC	45-66 Hz	900	48 VDC	2	2	40	17	29.55 x 20.8 x 17.5 in 750.6 x 528.3 x 444.5 mm	144	65

* Rectifier Weight Not Included (one Rectifier = 10 lbs)

Breaker Kits (ship separately):

SP4K - LMDC - () B1

Breaker Current Rating

Available Breaker Current Ratings:

1A, 2A, 3A, 5A, 10A, 15A, 20A, 25A, 30A, 35A, 40A, 50A, 60A, 70A, 80A, 100A, 125A, 150A, 200A

Breaker Positions Required:

1A - 100A = 1 Position
125A - 150A = 2 Positions
200A = 3 Positions



Rectifier



Single tier Distribution with built in Controller



Two tier Distribution

Model Number Nomenclature

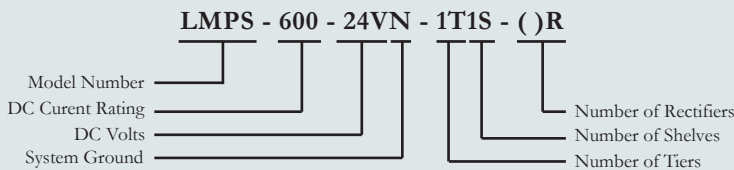

DC Current Rating	System Ground	DC Volts	Number of Tiers	Number of Shelf
600A (One Tier Only)	N = Negative Ground	24V	1T = One Tier	1S = One Shelf
1200A (Two Tier Only)	Note: Positive Ground is Standard Unless "N" is Entered for Negative Ground	48V	2T = Two Tiers	2S = Two Shelves

Ordering Information

When Ordering, Please Specify:

- La Marche Model Number
- DC Amps
- DC Volts
- System Ground
- Number of Tiers
- Number of Shelves
- Number of Rectifiers



LaMARCHE®

ISO 9001 CERTIFIED



19" and/or 23" TPM Cage shown above with (4) TPM Rectifiers

TOTAL POWER MODULE SWITCHMODE RECTIFIER SYSTEMS

The LaMarche TPM (Total Power Module) Switchmode Rectifier Systems are compact self contained Power Systems that provide the Modular Power that today's Telecommunications, Process Control and Utility Substation applications require. The TPM Switchmode Rectifier is the building block of these reliable systems utilizing advanced switching technology. Its filtered output provides the clean power required for sensitive loads.

The TPM is rated at 750 watts and available in 24V (30 amps) and 48V (15 amps) versions. A 12V TPM module is also offered and rated at 375 watts (30 amps). The Rectifier modules are hot-swappable plug-in type. Replacement is swift and simple, and achieved without affecting the integrity of the system.

The universal input voltage range of 102-264VAC and frequency of 47-63Hz is ideal for power demands throughout the world. The AC input and DC output wiring of the Rectifiers can be done either in pairs from the same side of the cage or as a complete system. A convenient AC input cord (6 ft long, 20A rated) is supplied to power each pair of TPMs Rectifiers per cage. The DC output wiring is done by hardwiring to the provided busbar.

Flexibility is given to hardwire a single connection for all Rectifiers or for each pair of Rectifiers per cage. This allows for custom field installations and gives greater system flexibility to suit the customer needs and preferences.

TPM Systems are factory configured with one to four Modules in a single Cage. Distribution Modules consisting of either GMT Fuses or Breakers can share a Cage with the Rectifiers to form a complete Power System.

A wall mounting configuration is offered for smaller load requirements or when rack mounting is not available. One or two TPM's can be fitted in our TPW cage. A separate Distribution Module can also be provided.

Rely on LaMarche quality, reliability and performance to power your present and future system needs.

TPM SYSTEMS SWITCHMODE RECTIFIER SYSTEMS

Standard Features

- High Frequency Switchmode Circuitry provides High Power Density
- Hot Plug-In feature provides easy replacement without disturbing System operation
- 24 and 48VDC Versions—750 Watts Output Power
- 12VDC Version—375 Watts Output Power
- 19" and 23" Rack Mounting (using TPC cages)
- Wall Mounting Configurations (using TPW cages)
- Universal Input Voltage Range from 102-264VAC and Frequency Range of 47-63Hz
- AC Input Breaker Mounted on Cage for each TPM
- Output Voltage Adjustment Potentiometer
- Test Points for Measuring Output Current and Voltage using a Precision Multi-Meter
- Current Limiting Circuitry of 105% maximum (factory adjusted)
- Power Factor Correction better than 0.95 within 20-100% of rated load
- Filtered/Battery Eliminator Design—less than 150mVp-p, 32dB RN "C" message weighted with or without Batteries
- 82% Efficiency within 50 to 100% of rated load
- Forced Load Sharing Circuitry (10% of rated load)
- Soft Walk-in Circuit
- Over Temperature and Voltage Protection
- Rectifier Failure Alarm with (1) set of Form "C" contacts with Light (Alarm will initiate for either Low Voltage, High Voltage Shutdown, Low DC Current, Rectifier Failure or AC Power Failure/AC Breaker Tripped)
- 6ft (1.83m) 20Amp Power Cord supplied with Cage for every (2) TPM modules
- 2-year Warranty

SPECIFICATIONS

ELECTRICAL

AC INPUT

Voltage Range

102-264VAC, single phase

Frequency Range

47-63Hz

Power Factor Correction

Better than 0.95 within 20 to 100% of rated load

Protection

AC Breaker provided on Cage for each unit

DC OUTPUT

Adjustable Output Voltage Range

12 to 14.5VDC on 12V models

24 to 29VDC on 24V models

48 to 58VDC on 48V models

Power

375W per 12VDC module, 1500 Watts per Cage

750W per 24 & 48VDC module, 3000 Watts per Cage

Voltage Regulation

± 0.6% Total DC Voltage Regulation (Measured at Rectifier side of blocking diode)

Current Limit

105% of rated output maximum (factory adjusted)

Load Sharing

Forced Load Sharing Circuitry

(10% of rated load)

Protection

Over Voltage, Over Temperature

Efficiency

82% within 50-100% of rated load

Ripple and Noise

Less than 150mV peak to peak, 32dB_{RNC} "C" message weighted, with or without batteries

Test Points

For output current and output voltage using a precision digital voltmeter

ENVIRONMENTAL

FCC Approved Part 15, Subpart B, Class A

IEC-555-2 Compliant

Operating Temperature: 0 to 50° C (32 to 122° F)

Storage Temperature: -40 to 85° C (-40 to 185° F)

Relative Humidity: 0 to 95% (non-condensing)

Altitude: 0 to 3,000 meters (10,000 ft)

ENCLOSURES

TPM Rectifiers

Dimensions

3.25"W x 11.0"D x 5.25"H (83 x 279 x 133 mm)

Weight

4 lbs each (1.8 kgs)

Mounting

19"/23" Rack Mount TPC Cages or TPW Wall Mount Cages

TPC Cages

Dimensions for 19" Rack

18.25"W x 15.29"D x 7"H (464 x 388 x 178 mm)

Dimensions for 23" Rack

18.25"W x 15.00"D x 5.25"H (464 x 381 x 133 mm)

Weight

23lbs to 26 lbs (10.5kgs to 11.8 kgs)

TPC23: 36 lbs (16.4kgs)

Mounting

TPC = 3 RU's

TPC23 = 4 RU's

AGENCY APPROVALS

U.L. Recognized Component

TPM Modules

Model Number	DC Amps	DC Volts	AC Input Voltage Range	Typical AC Input Current Draw @100% Load* (Amps)
TPM-30-12V-U1	30	12	102-264	5
TPM-30-24V-U1	30	24	102-264	9
TPM-15-48V-U1	15	48	102-264	8.5

TPC Cages

Model Number	Description	No of Available Bays	DC Amps	DC Volts	No of Input Cords	Rack Mounting
TPC-120-12V-U1	1-4 modules	4	120	12	2	19"/23"
TPC-120-24V-U1			120	24	2	19"/23"
TPC-60-48V-U1			60	48	2	19"/23"
TPC-60-12V-U1	1-2 modules with TPCD or TPCDB1	2 + 1	60	12	1	19"/23"
TPC-60-24V-U1			60	24	1	19"/23"
TPC-30-48V-U1			30	48	1	19"/23"
TPC23-60-48V-U1	1-4 modules with TPCD or TPCDB1	4 + 1	60	48	2	23"

Units can be mounted flush with the rack or moved forward 5 inches (127mm). Allow an additional .75 inches (19mm) for handles.



TPC cage 19.0" or 23.0" mounting reversible flange provided

TPC Rectifier Cage with (2) TPM Rectifiers and TPCD Fuse Distribution Module



TPC23 cage 23.0" mounting only

TPC23 Rectifier Cage with (4) TPM Rectifiers and TPCDB1 Breaker Distribution Module

TPCD (GMT Fuses) / TPCDB1 (Breakers) Distribution Modules

Model Number	DC Volts	DC Amps Rating	Battery Disconnect Breaker	GMT Fuses Qty (12) 0-10A	1-Pole Breakers Qty (7) 10A	LVLD Low Voltage Load Disconnect	Digital Meter & Alarm	Shipping Weight (Approximate)	
								lbs	kgs
TPCD-30-12V	12	30	40A	✓	---	✓	---	7	3.2
TPCD-30-24VN	24	30	40A	✓	---	✓	---	7	3.2
TPCD-30-48V	48	30	40A	✓	---	✓	---	7	3.2
TPCDB1-60-12V	12	60	70A	---	✓	✓	✓	9	4.1
TPCDB1-60-24VN	24	60	70A	---	✓	✓	✓	9	4.1
TPCDB1-60-48V	48	60	70A	---	✓	✓	✓	9	4.1

Above 12V & 48V Distribution Modules are configured for Positive Ground System as standard. For Negative Ground System order part number with "N" following voltage. Above 24V Distribution Modules are configured for Negative Ground System - delete "N" in part number to order Positive Ground. Please consult factory for other available Distribution Module configurations should above not meet your requirement.

TPCD Distribution Module - GMT Fuses

Features

- 12, 24 & 48VDC versions
- Maximum system current rating of 30A
- Low Voltage Disconnect w/field adjustable calibration mode and Alarm with (1) set of Form "C" contacts
- 40 Amp battery Disconnect Breaker
- (12) 0-10 GMT type Fuses
- Fuse open Alarm with (1) set of Form "C" contacts & LED indicator
- Low Voltage Alarm with (1) set of Form "C" contacts
- Front panel adjustments for all Alarm set points

TPCDB1 Distribution Module - Breakers

Features

- 12, 24 & 48VDC
- Maximum system current rating of 60Amp
- Switch selectable 1% Load Digital Ammeter/Voltmeter
- Low Voltage Disconnect w/field adjustable calibration mode
- 70 Amp Battery Disconnect Breaker
- (7) 10 Amp single pole Breakers
- Summary Alarm with (2) sets of Form "C" contacts indicating Low DC Current, Low DC Voltage, Low Voltage Disconnect, High Voltage, Rectifier Failure, Breaker Tripped
- Low DC Current, Low DC Voltage, Critical (2nd) Low DC Voltage, High DC Voltage and Summary Alarm LED's

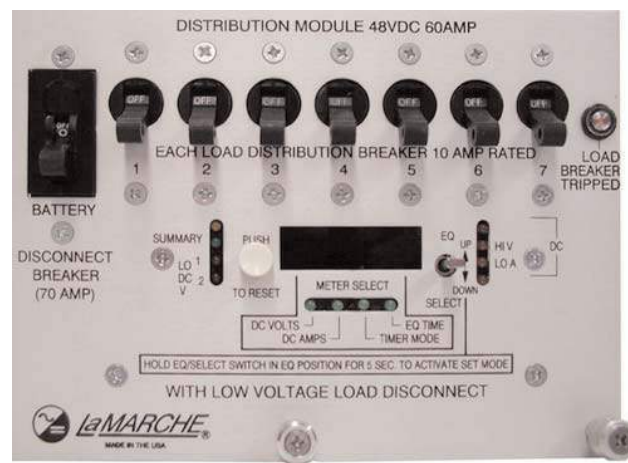
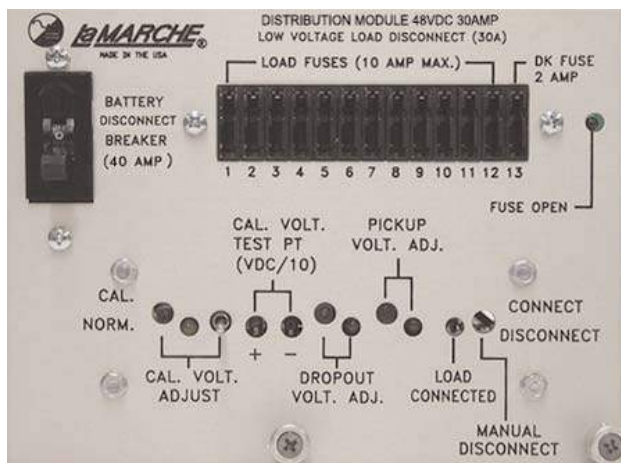

The TPCD GMT Fuse Distribution Modules are rated at 30A of maximum capacity and occupy (2) bay positions within our TPC cages. The TPCD Modules incorporate the most common features required to distribute your loads without having to resort to a larger chassis. The TPCD's are equipped with (12) GMT type Fuses for distribution of supervisory equipment. A 40 Amp Battery Disconnect allows the user to manually disconnect the battery bank for servicing or for replacement purposes. A Fuse Open Alarm consisting of a set of Form "C" contacts is provided to remotely report this Alarm condition along with an LED on the front panel for local supervision. An LVLD (Low Voltage Load Disconnect) is included to automatically disconnect the load from the system to prevent the battery from being overly discharged. A Bus return and terminal strip connector for the load side connection (#12 AWG wire) and a 70A Battery terminal strip to accommodate #6 AWG wire is provided for the battery connection.

The TPCDB1 Breaker Distribution Modules are rated at 60A of maximum capacity. Like the TPCD Fuse version, (2) bay positions are required within our TPC Cages. The TPCDB1's feature a digital switch selectable 1% accuracy Ammeter/Voltmeter. The TPCDB1's are equipped with (7) single pole 10 Amp Breakers for distribution of loads. A 70 Amp Battery Disconnect allows the user to manually disconnect the Battery Bank for servicing or for replacement purposes. A Breaker Tripped Alarm consisting of a set of Form "C" contacts is provided to remotely report this Alarm condition along with an LED on the front panel for local supervision. An LVLD (Low Voltage Load Disconnect) is included to automatically disconnect the load from the system to prevent the Battery from being overly discharged. A Bus return and terminal strip connector for the load side connection (#12AWG wire) and a 70A Battery terminal strip to accommodate #6 AWG wire is provided for the battery connection.

TPM SYSTEMS

SWITCHMODE RECTIFIER SYSTEMS

TPW Wall Mounted Systems

Model Number	Mounting Type	No of Available Bays	DC Volts	DC Amps Rating	Overall Dimensions Width x Depth x Height		Shipping Weight (Approximate)	
					in	mm	lbs	kgs
TPWH1-30-12V-U1	Hinge	1	12	30	15.08x6.38x7.00	383x162x133	16	7.3
TPWH1-30-24V-U1	Hinge	1	24	30			16	7.3
TPWH1-15-48V-U1	Hinge	1	48	15			16	7.3
TPWH2-60-12V-U1	Hinge	2	12	60	15.08x9.30x5.22	383x236x133	17	7.7
TPWH2-60-24V-U1	Hinge	2	24	60			17	7.7
TPWH2-30-48V-U1	Hinge	2	48	30			17	7.7
TPW2-60-12V-U1	Standard	2	12	60	17.78x9.30x7.72	451x236x196	10	4.5
TPW2-60-24V-U1	Standard	2	24	60			10	4.5
TPW2-30-48V-U1	Standard	2	48	30			10	4.5
TPWD-60-12V	Standard	Distribution	12	60	13.70x6.50x7.00	348x165x178	12	5.5
TPWD-60-24V-N	Standard	Distribution	24	60			12	5.5
TPWD-60-48V	Standard	Distribution	48	60			12	5.5

Above TPWD 12V & 48V Distribution Modules are configured for Positive Ground System as standard. For Negative Ground System order part number with "N" following voltage. Above TPWD 24V Distribution Module is configured for Negative Ground System—delete "N" in part number to order Positive Ground.

The LaMarche TPW (Wall Mounted Systems) offers an alternative solution to relay rack mounting for applications requiring a small and highly compact DC Power System. Designed to contain LaMarche TPM Rectifiers, the TPW enclosure's versatility can be used in a wide variety of applications, including Process Control, Utility Substation, and Telecommunications.

The TPWH1 (single TPM) and TPWH2 (dual TPM capability) features a hinged wall mounted bracket for either right or left swing out. This allows for front accessibility and simplifies the installation and removal of TPM units in tight quarters.

The TPW2 version is a fixed wall mounted enclosure for use where space is not restrictive. With dual Rectifier capability—(2) TPM Rectifiers can be installed to provide redundancy or to simply increase the system's capacity.

The TPWD is a wall mounted Distribution system offered in conjunction with a TPW enclosure to form a complete DC Power System. Standard features include (9) 10A GMT Load Fuses, Battery and Rectifier Terminal Connections, Single Form "C" Blown Load Fuse Alarm Contacts and LED, and Load and Common Return Terminal Strip Connections. The front panel of the TPWD enclosure has a hinged front door which allows easy access for wiring connections in the field.

A Low Voltage Load Disconnect Relay with factory settings and LED's indicating Connect/Disconnect and Single Form "C" Low Voltage Alarm Contacts is offered as an option. The maximum rating of the TPWD Distribution system is 60 Amps.

TPW Enclosures



TPWH1 Hinged Single Rectifier Bay shown above with hinge on left hand side



TPW2 Standard (non-hinged) Dual Rectifier Bay shown above

TPWD Distribution Module



Specifications subject to change without notice

P25-DSTPM-1
ECN 15551
09-02



106 Bradrock Drive, Des Plaines, IL 60018-1967
Tel: 847-299-1188 Toll Free Fax: 888-232-9562
sales@lamarchemfg.com www.lamarchemfg.com



Unit Shown with LED Display



Unit Shown with VFD Display



Controlled Ferroresonant Rectifier / Power Supply

The La Marche Model A36D Controlled Ferroresonant Rectifier / Power Supply has many inherent advantages such as voltage regulation, high efficiency, high power factor and short circuit protection. These chargers provide adjustable voltage levels for floating or equalizing lead or nickel-cadmium cells, which can be done digitally with the LCD/VFD display options. The equalize cycle is activated either manually through a switch on the front panel, or automatically scheduled (adjustable through the menu).

Steady state output voltage remains within $\pm 0.5\%$ of the setting from no load to full load and for AC input voltages within $\pm 10\%$ of the nominal input voltage. The model A36D is internally filtered to be no greater than 32dBm (“C” message weighting) and 30 millivolts RMS for all conditions on input voltage and output load with or without batteries connected. This allows the A36D to be used as a battery eliminator.

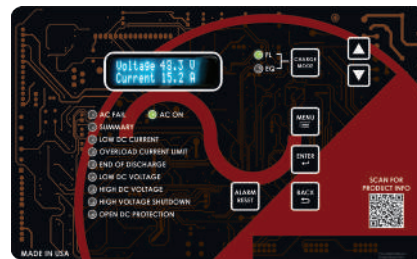

LCD Display
(Option 550)



VFD Display
(Option 551)

Standard Features

- Digital Metering
- Load Sharing / Paralleling
- Current Walk In
- Equalize Timer - adjustable from 1-144 hours with five selectable modes of operation (manual, automatic every 7, 14 or 30 days and equalize after sensing a low DC voltage)
- LED Status Indicators:
 - Float & Equalize Voltage, AC “ON”, Low DC Current, Low & High DC Voltage, Blown DC Protection, Summary
- AC Input Breaker
- One Pole DC Output Breaker / Single Phase Units
- Output Fusing / Three Phase Units
- AC Power Failure Alarm, One form “C” Contact
- 2 Form “C” Contacts for each of the following:
 - Low DC Current
 - Low DC Voltage
 - High DC Voltage
 - High Voltage Shutdown
 - Summary Alarm
 - Load Sharing
- Temperature Compensation
- UL 1012, CSA Listed
- 5 Year Warranty

A36D with LCD/VFD Display (Option 550/551)

A36D units equipped with an LCD or VFD display support the same features as standard units plus the following additions:

- 2 Line LCD or VFD Display
- Digital adjustments for the Charger Output (No Potentiometers), Alarms and Communication Settings
- User-Friendly Menu structure with push-button switches for ease of navigation
- Completely Configurable Alarm System
 - Alarm Thresholds
 - Delays
 - Contact Operations (Latching/Non-latching)
- Alarm Contacts testing capability to confirm functionality (Via front panel or remotely with optional communication card)
- Additional LED Indicators
 - AC Power Fail
 - Overload Alarm
 - End of Battery Discharge
 - High Voltage Shutdown
- Quick Start Instructions on the Front Panel with QR Code Link to the Charger’s Instruction Manual



Specifications

ELECTRICAL

- **AC Voltage**
Voltage range: $\pm 10\%$ from nominal
Frequency range: 60 Hz or 50 Hz $\pm 5\%$
Single Phase models:
120VAC, 208VAC, 220VAC, and 240VAC
Three Phase models:
208VAC, 240VAC, 380VAC, and 480VAC
- **DC Output**
DC Amps: 15 to 400 Amps
DC Volts: 12V, 24V and 48V
Output Filtering: 30m Vrms
- **Efficiency**
Up to 90%
- **Power Factor**
Up to 0.95
- **DC Voltage Regulation Steady-State**
 $\pm 0.5\%$ of the setting from no load to full load over the specified input voltage, frequency and ambient temperature ranges.
- **Dynamic Response (On Battery)**
Voltage transient $< \pm 5\%$ over a step change in the load from 20% to 100%
Recovery Time $< 200\text{mS}$
- **Audible Noise**
Less than 65dBA at any point 5 feet from any vertical surface of the charger / power supply.
- **Voice Band Noise Filtering**
Less than 22dB when tested according to REA Form 524. All A36D units are filtered to 32 dBrn "C" with or without batteries connected.
- **Load Sharing**
Identical La Marche A36D units, when connected in parallel, are capable of sharing the DC load within $\pm 5\%$ for individual unit outputs greater than 5% of the rated output. Two sets of form "C" contacts are provided to indicate when connected rectifiers are capable of loadsharing.
- **Temperature Compensation**
5 step curve with an average slope of $-0.001\text{v}/\text{cell}/\text{C}^\circ$
Consult factory for other compensation rates.
- **Remote Equalize**
When Remote Equalize feature is enabled, switching one A36D charger into Equalize mode would switch all other parallel A36D chargers, in the system, into Equalize mode.

PROTECTION

- **Current Limit**
Electronic Current Limit circuit with an adjustable range from 90% to 115%. A36D has an inherent magnetic current limiting feature to protect against short circuits.

PROTECTION

- **Current Walk In**
Output current will gradually increase after the charger is turned on eliminating surges and overshoot.
- **AC Breaker**
A two pole breaker, on single phase units opens both legs of the AC service to 208 and 240. Breaker opens phase side of 120 VAC service. A three pole breaker is supplied on three phase units.
- **DC Breaker / DC Fuse**
A single pole output breaker is supplied as standard on single phase units. A DC Fuse is standard on three phase units.
- **Alarm Relay Contact**
Form "C" Alarm Contacts for:
 - AC Power Failure
 - High Voltage Shutdown
 - High DC Voltage
 - Low DC Voltage
 - Low Current
 - Summary Alarm

MEAN TIME BETWEEN FAILURE

The mean time between failure (MTBF) as tested per the Bell Communications Standard TR-TSY-000332 is 225,000 hours at 50°C.

REMOTE MONITORING

- Form "C" Alarm Contacts
- With optional Communications Card:
 - Connect to SCADA System
 - Web Monitoring
 - Alarm / Notification E-mails

ENCLOSURES

Pretreated with a seven stage iron phosphate wash, sealer and deionized rinse. Then coated with an environmentally safe and durable ANSI 61 gray Polyester TGIC Minite powder finish.

ENVIRONMENTAL

- **Operating Temperature**
0 to 50°C
- **Storage Temperature**
-40 to 85°C
- **Humidity**
0 to 95% Relative Humidity (Non-Condensing)
- **Cooling**
Convection cooled

Optional Accessories

- 550** Digital Controller with LCD Display
- 551** Digital Controller with VFD Display
- 11W** 15 Foot External Temperature Probe
- 09A** UL 1481 Label (Fire Alarm). Available For 48V 60 Hz Single Phase Models Only
- 09C** I.D. Tags (Black / White / Black)
- 09V** I.D. Tags (White / Black / White)
- 09U** Seismic Bracing
- 012** DC BKR 1P

Communication Protocols

- 21J** IEC 61850
- 21P** DNP 3.0 Communications RS232/RS485/Ethernet
- 21Q** Modbus Communications RS232/RS485/Ethernet
- 21S** Modbus RTU - Serial Data Port
- 21X** SNMP



Standard LED Display

TABLE OF CONTENTS

1-Phase																
Model Number	DC Amps	DC Protection	60Hz							50Hz ⁽³⁾					Heat Loss BTU's/ Hour ⁽⁴⁾	
			AC Current Draw ⁽¹⁾ Recommended Feeder AC Supply Breaker				Case No.	Shipping Weight		AC Current Draw ⁽¹⁾ Feeder AC Supply Breaker		Case No.	Shipping Weight			
			A1 120	ABD1 120/240/208	BLD1 240/220/208	Feeder** Breaker Size		lbs	kgs	5BL1 240/220	Feeder** Breaker Size		lbs	kgs		
12 Volt ⁽²⁾	A36D-15-12V	15A	25	2.4	---	---	5.0	39	45	20.4	---	---	---	---	---	429
	A36D-20-12V	20A	30	3.2	---	---	7.5	39	50	22.7	---	---	---	---	---	388
	A36D-25-12V	25A	40	4.0	---	---	7.5	39	54	24.5	---	---	---	---	---	347
	A36D-30-12V	30A	40	5.0	---	---	10.0	33	78	35.4	---	---	---	---	---	674
	A36D-50-12V	50A	80	---	8.4/4.2/4.8	---	20.0/10.0/10.0	33	99	45	4.2/4.6	10	33	109	49.5	695
	A36D-75-12V	75A	100	---	12.6/6.3/7.3	---	30.0/15.0/15.0	33E	110	50	6.3/6.9	15	33	121	55	1043
	A36D-100-12V	100A	130	---	16.8/8.4/9.7	---	30.0/15.0/15.0	33E	130	59	8.4/9.2	15	4D	143	64.9	1227
	A36D-150-12V	150A	200	---	25.2/12.6/14.5	---	30.0/15.0/15.0	9D	145	65.8	12.6/13.8	15	9D	160	72.6	3068
A36D-200-12V	200A	250	---	33.6/16.8/19.4	---	40.0/20.0/20.0	9D	180	81.6	16.8/18.3	20	9D	198	90	3272	
24 Volt ⁽²⁾	A36D-10-24V	10A	15	3.3	---	---	5.0	39	50	22.7	---	---	---	---	---	150
	A36D-12-24V	12A	15	4.0	---	---	7.5	39	54	24.5	---	---	---	---	---	191
	A36D-15-24V	15A	25	5.0	---	---	7.5	39	58	26.3	---	---	---	---	---	241
	A36D-20-24V	20A	30	6.7	---	---	10.0	39	64	29	---	---	---	---	---	321
	A36D-25-24V	25A	40	---	8.4/4.2/4.8	---	15.0/7.5/7.5	33	99	44.9	4.2/4.6	7.5	33	109	49.5	402
	A36D-30-24V	30A	40	---	10.0/5.0/5.8	---	15.0/7.5/7.5	33	115	52.2	5.0/5.5	7.5	33	127	57.6	482
	A36D-50-24V	50A	80	---	16.8/8.4/9.7	---	30.0/15.0/15.0	33	130	59	8.4/9.2	15.0	33	143	64.9	803
	A36D-75-24V	75A	100	---	25.2/12.6/14.5	---	40.0/20.0/20.0	33E	145	65.8	12.6/13.8	20.0	33E	160	72.6	1205
A36D-100-24V	100A	130	---	33.6/16.8/19.4	---	40.0/20.0/20.0	33E	180	81.6	16.8/18.3	20.0	33E	198	89.8	1606	
A36D-150-24V	150A	200	---	50.5/25.2/29.1	---	70.0/35.0/35.0	9D	280	127	25.2/27.5	35.0	9D	309	140.1	2410	
A36D-200-24V	200A	250	---	67.0/33.6/38.8	---	80.0/40.0/40.0	9D	310	140.6	33.6/36.7	40.0	9E	342	155.1	3213	
48 Volt ⁽²⁾	A36D-10-48V	10A	15	6.7	---	---	10.0	39	64	29	---	---	---	---	---	312
	A36D-12-48V	12A	15	8.0	---	---	15.0	39	70	31.7	---	---	---	---	---	383
	A36D-15-48V	15A	25	10.0	---	---	15.0	33	110	49.9	---	---	---	---	---	386
	A36D-20-48V	20A	30	---	13.4/6.7/7.7	---	15.0/7.5/7.5	33	118	53.5	6.7/7.3	7.5	33	130	59	643
	A36D-25-48V	25A	40	---	16.8/8.4/9.7	---	30.0/15.0/15.0	33	125	56.7	8.4/9.2	15.0	33	138	62.6	803
	A36D-30-48V	30A	40	---	20.0/10.0/11.6	---	30.0/15.0/15.0	33	133	60.3	10.1/11.0	15.0	33	147	66.7	964
	A36D-50-48V	50A	80	---	33.6/16.8/19.4	---	50.0/25.0/25.0	33	180	81.6	16.8/18.3	25.0	33	198	89.8	1606
	A36D-75-48V	75A	100	---	50.4/25.2/29.1	---	70.0/35.0/35.0	9D	260	118	25.2/27.5	35.0	9D	287	130.2	2410
	A36D-100-48V	100A	130	---	67.2/33.6/38.8	---	80.0/40.0/40.0	9D	286	129.7	33.6/36.7	40.0	9E	315	142.9	3213
	A36D-150-48V	150A	200	---	---	50.4/55.0/58.2	70.0	72	528	239.5	---	---	---	---	---	4819
A36D-200-48V	200A	250	---	---	67.3/73.3/77.6	80.0	72	572	259.5	---	---	---	---	---	6426	

3-Phase																
Model Number	DC Amps	DC Protection	60Hz							50Hz ⁽³⁾					Heat Loss BTU's/ Hour ⁽⁴⁾	
			AC Current Draw ⁽¹⁾ Recommended Feeder AC Supply Breaker				Case No.	Shipping Weight		AC Current Draw ⁽¹⁾ Feeder AC Supply Breaker		Case No.	Shipping Weight			
			BD3 240/208V	Feeder** Breaker Size	C3 480V	Feeder** Breaker Size		lbs	kgs	5G3 380V	Feeder** Breaker Size		lbs	kgs		
24 Volt ⁽²⁾	A36D-200-24V	200A	250	16.9/19.5	25	---	---	43	600	272.1	10.7	15	43	661	299.8	2514
	A36D-300-24V	300A	400	25.4/29.3	35	---	---	43	700	317.5	16	20	43	771	349.7	3772
	A36D-400-24V	400A	500	33.9/39.1	50	---	---	43	800	362.9	21.4	25	44	881	399.6	5029
	A36D-200-24V	200A	250	---	---	8.5	15	43	600	272.1	10.7	15	43	661	299.8	2514
	A36D-300-24V	300A	400	---	---	12.7	20	43	700	317.5	16	20	43	771	349.7	3772
	A36D-400-24V	400A	500	---	---	16.9	25	43	800	362.9	21.4	25	44	881	399.6	5029
48 Volt ⁽²⁾	A36D-200-48V	200A	250	33.9/39.1	50	---	---	43	755	342.5	21.4	25	43	832	377.4	5029
	A36D-300-48V	300A	400	50.8/58.6	80	---	---	44	900	400.2	32.1	40	44	992	450	7543
	A36D-400-48V	400A	500	67.7/78.1	100	---	---	44	1193	541.1	42.8	50	44	1315	596.5	10057
	A36D-200-48V	200A	250	---	---	16.9	25	43	755	342.5	21.4	25	43	832	377.4	5029
	A36D-300-48V	300A	400	---	---	25.4	40	44	900	400.2	32.1	40	44	992	450	7543
	A36D-400-48V	400A	500	---	---	33.9	50	44	1193	541.1	42.8	50	44	1315	596.5	10057

- 1) AC Current Draws based @ 100% load and standard battery cells of 6L (12V), 12L (24V) and 24L (48V). Maximum Current Draw is 115% of ratings shown.
- 2) Must specify only one battery type and number of cells from range shown above. Please consult factory for other available cell ranges if desired range not shown.
- 3) 50Hz units are not UL listed. Please consult factory as enclosure size may change.
- 4) BTU's are based on 6L (12V), 12L (24V) and 24L (48V). Heat loss is stated for nominal float voltage, 100% output current and nominal AC line.

Output Voltage Chart

DC Voltage	12V	24V	48V
Number of Cells	6L*	12L*	24L*
Float	12.7 to 13.8	25.4 to 27.6	50.9 to 55.2
Equalize	13.6 to 14.4	27.1 to 28.8	54.2 to 57.6

* LR for VRLA Settings

NOTE: Consult Factory for Ni-Cad size availability

Single Phase 19" Rack Mount

	Model Number	DC Amps	AC Input (60Hz Single Phase)				Protection				Case No.	Approx. Weight		BTU's/ Hour
			Volts	Amperes			Input			Output		lbs	kg	
				120	208	240	120	208	240					
12 Volt	A36DA-30-12V-A1	30A	120	8.0	---	---	10.0	---	---	40A	4D	78	35.4	674
	A36DA-50-12V-ABD1	50A	120/208/240	8.0	5.0	4.0	20.0	10.0	10.0	80A	4D	99	44.9	695
	A36DA-75-12V-ABD1	75A	120/208/240	16.0	9.0	8.0	30.0	15.0	15.0	100A	4D	110	49.9	1043
24 Volt	A36DA-25-24V-ABD1	25A	120/208/240	8.0	5.0	4.0	15.0	7.5	7.5	40A	4D	99	44.9	402
	A36DA-30-24V-ABD1	30A	120/208/240	11.0	6.0	6.0	15.0	7.5	7.5	40A	4D	115	52.2	482
	A36DA-50-24V-ABD1	50A	120/208/240	16.0	9.0	8.0	30.0	15.0	15.0	80A	4D	130	59	803
48 Volt	A36DA-75-24V-ABD1	75A	120/208/240	24.0	15.0	12.0	40.0	20.0	20.0	100A	4D	145	65.8	1205
	A36DA-15-48V-A1	15A	120	10	---	---	15.0	---	---	25A	4D	110	49.9	482
	A36DA-20-48V-ABD1	20A	120/208/240	13.0	7.0	6.0	15.0	7.5	7.5	30A	4D	118	53.5	643
48 Volt	A36DA-25-48V-ABD1	25A	120/208/240	16.0	9.0	8.0	30.0	15.0	15.0	40A	4D	125	56.7	803
	A36DA-30-48V-ABD1	30A	120/208/240	18.0	11.0	9.0	30.0	15.0	15.0	40A	4D	133	60.3	964
	A36DA-50-48V-ABD1	50A	120/208/240	29.0	16.0	14.0	50.0	25.0	25.0	80A	4D	180	81.6	1606

Case Specifications

	Case No.	Overall Dimensions					
		Width		Depth		Height	
		in	mm	in	mm	in	mm
19" Rack	4D	16.75	425.45	15.0	381	14.0	355.6
	39	16.75	425.45	15.0	381	7.0	177.15
23" Rack	9E	21.0	533.4	23.0	584.2	17.25	438.15
	33	21.0	533.4	16.25	412.75	10.5	266.7
	33E	21.0	533.4	17.5	444.5	10.5	266.7
Floor Mounting	39	16.75	425.45	15.0	381	7.0	177.8
	43	13.0	330.2	19.0	482.6	84.0	2133.6
	44	24.0	609.6	19.0	483	72.1	1831.34
	72	27	685.8	23.5	596.9	44.5	1130.3

NOTE:

- 1) BTU's on single phase units based on 85% efficiency.
- 2) Input Amps are at Nominal AC input and at 100% of rated load.

Case No.	Cable Entry (when facing unit)		Standard Mounting	Optional Mounting Kits
	AC Input	DC Output		
4D	LEFT TOP / BACK	RIGHT TOP / BACK	19/23" RACK	WALL*, FLOOR**
39	LEFT TOP / BACK	RIGHT TOP / BACK	19/23" RACK	WALL*, FLOOR**
9E**	LEFT TOP / BACK	RIGHT TOP / BACK	23" RACK	WALL* / FLOOR**
33***	LEFT TOP / BACK	RIGHT TOP / BACK	23" RACK	WALL* / FLOOR**
33E	LEFT TOP / BACK	RIGHT TOP / BACK	23" RACK	WALL* / FLOOR**
43	TOP LEFT	TOP BACK	FLOOR	---
44	TOP LEFT	TOP BACK	FLOOR	---
72	RIGHT / BOTTOM / SIDE	BOTTOM	FLOOR	---

* Wall mounting brackets required and overall height would change. Case size may differ depending on optional accessories.
 ** Floor mounting brackets required and overall height would change. Case size may differ depending on optional accessories.
 Consult factory when dimensions are critical. Detailed dimensional drawings are available for mounting purposes.

Model Number Nomenclature

A36D(A) () - 50 - 24V - () ABD 1 - () - ()

Model Number: A36D(A) ()
 19" Rack: 50
 * Grounding: -
 DC Amps: 24V
 DC Volts: ()
 Factory Assigned Accessory Code: ABD
 Battery Cell Range: 1
 AC Phase: ()
 AC Voltage: ()
 **AC Input Frequency: ()

System Ground	Special Input Frequency	AC Voltage	AC Phase
N= Negative Ground * positive ground is standard unless "N" is entered for Negative ground.	5 = 50Hz ** Leave Blank for 60Hz	A=120 B=240 C=480 D=208 L=220 G=380	1 = Single Phase 3 = Three Phase

Ordering Information

When ordering, please specify:

- La Marche Model Number A36D
- DC Amps
- DC Volts
- Special Frequency, When Required
- AC Voltage Code
- AC Phase Code
- Battery Cell Type Code
- Optional Accessories (Option Code)

Battery Charger Sizing Guidelines

- Required Battery Backup Time (Hours)
- DC Output Voltage
- Ampere Hour Capacity of Battery
- Allowable Recharge Time From Full Discharge (Hours), Where Applicable
- Continuous and Intermittent DC Loads and Duration (Amps)



The Industry's Most Reliable Filtered Battery Charger / Power Supply



Standard



16 Series CAP
W/Breakers



46 Series CAP
W/Breakers



The La Marche model A12B Series Filtered Battery Chargers / Power Supplies are engineered for the demanding requirements of SwitchGear applications, Process Controls and Communications. The magnetic amplifier circuitry is designed to carry continuous and intermittent loads up to the maximum rated output. Its robust design and unmatched reliability has made this workhorse the standard in the industry and with its customizing features.

Refer to Digital C.A.P. System Data Sheet for complete details.

Standard Features

- Magnetic Amplifier Circuitry
- Separate Float and Equalize Potentiometers provide simple and precise DC Voltage calibration
- Float/Equalize Mode Switching
- Float and Equalize Lights
- Automatic AC Voltage Compensation
- +/- 0.5% DC Voltage Regulation
- Fused AC input and DC output protects Battery and Charger/Power Supply
- Analog DC Ammeter and DC Voltmeter
- Current Limiting Circuitry prevents overload and provides current control from 50 to 120% of rated output (factory set at 115%)
- Output Filtered (With or Without a Battery) - 30mV RMS for Single Phase Models and 100mV RMS for Three Phase Models
- AC Power Failure Relay with Form "C" Contacts
- AC Surge Suppression (MOV)
- NEMA Type 1 Enclosure / IP20
- UL 1012 & C-UL Listed (UL 1481 Listing available)
- 10-year Limited Warranty



Specifications

ELECTRICAL

- **AC Input Voltages**
Single Phase 60Hz: 120, 208, 220, 240, 480 or 600
Single Phase 50Hz: 220/240, 380 or 415
Three Phase 60Hz: 208, 240, 480 or 600
Three Phase 50Hz: 220/240, 380 or 415
Voltage range: +/- 10% from nominal
Frequency range: +/- 5%
- **Power Protection**
AC Fuse, DC Fuse and Current Limit Protection
- **DC Output Amps and Voltages**
DC Amps: 3 to 400 amperes
DC Volts: 12, 24, 48, 130VDC (Others available such as 32, 36 & 260VDC)
- **Output Filtering (With or without a battery)**
30mV RMS for single phase models and
100mV RMS for three phase models
- **DC Voltage Regulation**
Plus or minus 0.5% of setting from no load to full load over the specified input voltage, frequency and ambient temperature ranges.

ENVIRONMENTAL

- **Operating Temperature**
0° to 50°C (32° to 122°F)
- **Storage Temperature**
-40° to 85°C (-40° to 185°F)
- **Relative Humidity**
0 to 95% (non-condensing)
- **MTBF**
Exceeds 250,000 Hours
- **Dimensions**
Overall dimensions and weights are listed on the last page of this Data Sheet. Case specifications are subject to change due to innovative product development and design. When space requirements are critical, please consult the factory.
- **Mounting**
Floor or wall units are available. Mounting flanges are supplied as integral part of cabinet back plate on wall mounted models.
- **Finish**
Pretreated with a seven stage iron phosphate wash, sealer and deionized rinse. Then coated with an environmentally safe and durable ANSI 61 gray Polyester TGIC Minitel powder finish.

AGENCY APPROVALS

- **UL Battery Charger**
File E 319318, Guide BBML
UL Std. No. 1012
- **C-UL Battery Charger**
CAN/CSA
Std. C22.2 No. 107-2
- **UL Fire Alarm System Power Supply**
File S2768, Guide UTRZ
UL Std. No. 1481
Must Specify Accessory Code 09A
24V output, 240V or less, 60Hz single phase input only.

Notes:
All models where appropriate will carry the U.L. and C-U.L. Battery Charger listing. When U.L. Fire Alarm System Power Supply Listings are required, you must specify this requirement at the time of order. Not all models can be U.L. approved. Accessories, type of charger and rating will determine U.L. approval. Consult our factory if U.L. approvals are required.

Optional Accessories

ALARM & CONTROL

- **16 Series** (Refer to Digital C.A.P. Systems Data Sheet for complete details)
LED C.A.P. Systems common features:
Selectable Display, Multi-Mode Equalize Timer
Equalize Light
AC Power Failure Relay w/ (2) sets Form "C"
Low DC Current Alarm w/ (2) sets Form "C"
Low DC Voltage 1 Alarm w/ (2)sets Form "C" & Adjustable Time Delay (0-255 sec) (Except Ground Detection Alarms).
Multi-Mode Equalize Timer with Light adjustable from 1-144 hrs with five selectable modes and various failure alarm & lights.
- **46 Series** (Refer to Digital C.A.P. Systems Data Sheet for complete details)
2 Line LCD C.A.P. Systems common features:
Selectable Display, Multi-Mode Equalize Timer
Equalize Light
Float Light
AC Power Failure Relay w/ (2) sets Form "C" (Except 46Q)
Low DC Current Alarm w/ (2) sets Form "C"
Low DC Voltage 1 Alarm w/ (2)sets Form "C" & Adjustable Time Delay (0-255 sec) (Except Ground Detection Alarms).
Multi-Mode Equalize Timer with Light adjustable from 1-144 hrs with five selectable modes and various failure alarm & lights.
Discrete Alarm LEDs (46A & 46B) Available
- **46A** Discrete Alarm LEDs (with Ground Detection)
For use with CAP systems 46J, 46U, 46Q, 46T
- **46B** Discrete Alarm LEDs (w/o Ground Detection)
For use with CAP systems 46E, 46P, 46G, 46L
- **03N** Low DC Current Alarm & Light w/ (1) set Form "C" contacts
- **04J** Electronic Equalize Timer Multi-Mode adjustable from 2-144hrs with five selectable modes; Standard, 7-day, 14-day, 30-day and Equalize after Low DC Voltage.
- **050** Ground Detection Switch 3-position with DC Voltmeter indication (130VDC models utilizes two switches)
- **051** Ground Detection Alarm with Reset Pushbutton and (1) set form "C" Positive and (1) set form "C" Negative contacts
- **052** Ground Detection Lights (Positive and Negative)
- **053** Ground Detection Switch & Lights (130VDC models utilizes two switches)
- **054** AC Power Failure Light
- **16C** Hi/Lo-2 Combination Alarm High/Low DC Voltage, Field Calibrations & Adjustments, Individual Lights and (2) Form "C" contacts for each alarm
- **10G** Forced Load Sharing (with same model number only)
- **103** Remote Sensing
- **20Q** Equalize Fan Control Relay

METERING & PROTECTION

- **011** AC Breaker Single Pole (120VAC only)
- **012** DC Breaker Single Pole
- **016** AC Breaker Two Pole

METERING & PROTECTION CONTINUED

- **017** DC Breaker Two Pole
- **01B** AC Breaker Three Pole (3-phase input only)
- **01M** DC Breaker two Pole High Interrupting - 22KAIC (up to 250VDC)
- **01C** AC Breaker two Pole High Interrupting - 65/35/18KAIC (240/480/600VAC)
- **01D** AC Breaker two Pole High Interrupting - 100/65/25KAIC (240/480/600VAC)
- **01F** AC Breaker three Pole High Interrupting - 65/35/18 KAIC (240/480/600VAC)
- **01G** AC Breaker three Pole High Interrupting - 100/65/25KAIC (240/480/600VAC)
- **06G** Zero Center Ammeter w/Battery & Load Terminals (under 250A units)
- **06L** AC Ammeter +/-2% accuracy (single phase)
- **06M** AC Voltmeter +/-2% accuracy (single phase)
- **14V** AC Voltmeter with switch (three phase)
- **14W** AC Ammeter with switch (three phase)
- **102** DC Blocking Diode
- **107** DC Surge Protectors (MOV's)
- **11L** Lightning Arrestor
- **217** Reverse polarity Protection & LED

MISCELLANEOUS

- **09A** UL1481 (24V output, 240V or less, 60Hz single phase)
- **092** Tropicalization (magnetics only) Single Phase
- **093** Tropicalization (magnetics only) Three Phase
- **10B** USCG (U.S. Coast Guard) Accessories
- **10L** Battery & Load Terminals (under 250A units)
- **11F** 30mV Filtering for 3-phase units
- **38G** ABS (American Bureau of Shipping) Modifications
- **38J** ABS (38G) & USGC (10B) Single Phase
- **38K** ABS (38G) & USGC (10B) Three Phase
- **11V** Temperature Compensation (Internal Probe)
- **11W** External Temperature Probe 22 ft
- **38D** Copper Ground Bus Bar
- **095** Heat Shrinkable Wire Markers with Point to Point Wiring Diagram
- **09W** Heat Shrinkable Wire Markers with Electrical Schematic
- **09L** Physical Parts Location Drawing
- **097** SIS Wire (#16 AWG and larger) Markers
- **080** Drip Shield (must order separately)
- --- Floor Stand (must order separately)
- --- Special NEMA (3R, 4, 4X and 12) and IP Rated Enclosures

COMMUNICATION PROTOCOLS (Offered only with 46 series C.A.P.)

- **21J** IEC 61850 Ethernet
- **21P** DNP 3.0 Communications RS232/RS485/Ethernet
- **21Q** MODBUS Communications RS232/RS485/Ethernet
- **21S** MODBUS RTU Serial Data Port
- **21X** SNMP

Notes: Discrete Alarms are not available in conjunction with Digital C.A.P. (Combined Accessory Package) systems. Typically, when ordering two or more discrete components, the Digital C.A.P. system listed above provides a more economical approach.
Case sizes may differ depending on optional accessories and/or 50Hz input. Please consult factory when dimensions are critical.

TABLE OF CONTENTS

Please consult factory for other available cell ranges if desired range not shown.

Must specify only one battery type and number of cells from range shown above.

	Model Number	DC Amps	DC Fuse Size (Amps) ⁽¹⁾	AC Input Phase	AC Input Current Draw @ 100% Load (Amps) ⁽²⁾										Std. Case Size ⁽⁴⁾	Shipping Weight (Approximate)	
					60Hz Units					50Hz Units						lbs	kgs
					A 120	D 208	L 220	B 240	C 480	ZD 600	B 240 / L 220	G 380	J 415				
12 volt systems (6L, 9 or 10NC)	A12B-3-12V	3	10	1	0.8	0.4	0.4	0.4	---	---	---	0.4 / 0.4	---	---	7	60	28
	A12B-6-12V	6	15	1	1.5	0.9	0.8	0.8	---	---	---	0.8 / 0.8	---	---	7	70	32
	A12B-10-12V	10	20	1	2.5	1.4	1.4	1.3	---	---	---	1.3 / 1.4	---	---	7	80	37
	A12B-15-12V	15	25	1	3.8	2.2	2.1	1.9	---	---	---	1.9 / 2.1	---	---	3	90	41
	A12B-20-12V	20	30	1	5	2.9	2.7	2.5	---	---	---	2.5 / 2.7	---	---	3	95	44
	A12B-30-12V	30	40	1	7.5	4.3	4.1	3.8	1.9*	1.6*	---	3.8 / 4.1	2.4*	2.2*	3	105	48
	A12B-40-12V	40	60	1	10	5.8	5.5	5	2.5*	2.1*	---	5 / 5.5	3.2*	2.9*	6	155	71
	A12B-50-12V	50	80	1	13	7.2	6.8	6.3	3.1*	2.6*	---	6.3 / 6.8	4.0*	3.6*	6	170	78
	A12B-60-12V	60	80	1	15	8.7	8.2	7.5	3.8*	3.1*	---	7.5 / 8.2	4.7*	4.3*	6	180	82
	A12B-75-12V	75	100	1	19	11	11	9.4	4.7*	3.9*	---	9.4 / 11	5.9*	5.4*	6	225	103
A12B-100-12V	100	150	1	25	14	14	13	6.3*	5.2*	---	13 / 14	7.9	7.2	8A	315	143	
	100	150	3	---	7.5	7.1	6.5	3.3*	2.7*	---	6.5 / 7.1	4.1*	3.8*	8A	325	148	
24 volt systems (12L, 18, 19 or 20NC)	A12B-3-24V	3	10	1	1.5	0.9	0.8	0.8	---	---	---	0.8 / 0.8	---	---	7	70	32
	A12B-6-24V	6	15	1	3	1.7	1.6	1.5	---	---	---	1.5 / 1.6	---	---	3	85	39
	A12B-10-24V	10	20	1	5	2.9	2.7	2.5	---	---	---	2.5 / 2.7	---	---	3	95	44
	A12B-15-24V	15	25	1	7.5	4.3	4.1	3.8	1.9*	1.6*	---	3.8 / 4.1	2.4*	2.2*	3	100	46
	A12B-20-24V	20	30	1	10	5.8	5.5	5	2.5*	2.1*	---	5 / 5.1	3.2*	2.9*	3	120	55
	A12B-25-24V	25	35	1	13	7.2	6.8	6.3	3.1*	2.6*	---	6.3 / 6.8	4.0*	3.6*	3	135	62
	A12B-30-24V	30	40	1	15	8.7	8.2	7.5	3.8*	3.1*	---	7.5 / 8.2	4.7*	4.3*	3	145	66
	A12B-35-24V	35	50	1	18	11	9.6	8.8	4.4*	3.7*	---	8.8 / 9.6	5.5*	5.1*	6	190	87
	A12B-40-24V	40	60	1	21	12	11	10	5*	3.2*	---	10 / 11	6.3*	5.8*	6	205	93
	A12B-50-24V	50	80	1	26	15	14	13	6.3*	5.2*	---	13 / 14	7.9	7.2	6	240	109
	A12B-60-24V	60	80	1	31	18	17	15	7.5	6.3*	---	15 / 17	9.5	8.7	6	265	121
	A12B-75-24V	75	100	1	38	22	21	19	9.4	7.8	---	19 / 21	12	11	70	400	182
	A12B-100-24V	100	150	1	51	29	28	26	13	11	---	26 / 28	16	15	70	450	205
		100	150	3	---	16	15	13	7	6	---	13 / 15	8.5	8	70	500	227
	A12B-125-24V	125	200	3	---	19	18	17	8.1	6.8*	---	17 / 18	11	9.4	70	525	239
A12B-150-24V	150	200	3	---	23	22	20	9.8	8.2	---	20 / 22	13	12	72	630	286	
A12B-200-24V	200	250	3	---	30	29	26	13	11	---	26 / 29	17	16	27	825	375	
A12B-250-24V	250	300	3	---	38	36	33	17	14	---	33 / 36	21	19	27	880	400	
A12B-300-24V	300	400	3	---	46	43	40	20	17	---	40 / 43	25	23	27	940	427	
A12B-400-24V	400	600	3	---	61	57	53	26	22	---	53 / 57	33	31	47	1350	613	
48 volt systems (24L, 36, 37 or 38NC)	A12B-3-48V	3	10	1	3	1.7	1.6	1.5	---	---	---	1.5 / 1.6	---	---	7	85	39
	A12B-6-48V	6	15	1	6	3.5	3.3	3	---	---	---	3 / 3.3	---	---	3	90	41
	A12B-10-48V	10	20	1	10	5.8	5.5	5	2.5*	2.1*	---	5 / 5.5	3.2*	2.9*	3	140	64
	A12B-15-48V	15	25	1	15	8.7	8.2	7.5	3.8*	3.1*	---	7.5 / 8.2	4.7*	4.3*	3	180	82
	A12B-20-48V	20	30	1	21	12	11	10	5*	4.2*	---	10 / 11	6.3*	5.8*	6	205	93
	A12B-25-48V	25	35	1	26	15	14	13	6.3*	5.2*	---	13 / 14	7.9	7.2	6	240	109
	A12B-30-48V	30	40	1	31	18	17	15	7.5	6.3*	---	15 / 17	9.5	8.7	6	265	121
	A12B-40-48V	40	60	1	41	24	22	21	10	8.4	---	21 / 22	13	12	6	275	125
	A12B-50-48V	50	80	1	51	29	28	26	13	11	---	26 / 28	16	15	8A	355	161
	A12B-60-48V	60	80	3	---	18	17	16	7.8	6.5*	---	16 / 17	9.9	9	8A	400	182
	A12B-75-48V	75	100	3	---	23	22	20	9.8	8.2	---	20 / 22	13	12	72	525	239
	A12B-100-48V	100	150	3	---	30	29	26	13	11	---	26 / 29	17	16	72	625	284
	A12B-125-48V	125	200	3	---	38	36	33	17	14	---	33 / 36	21	19	72	700	318
	A12B-150-48V	150	200	3	---	46	43	40	20	17	---	40 / 43	25	23	27	850	386
	A12B-175-48V	175	250	3	---	53	50	46	23	19	---	46 / 50	29	27	27	1000	454
A12B-200-48V	200	250	3	---	61	57	53	26	22	---	53 / 57	33	31	27	1150	522	
A12B-250-48V	250	300	3	---	76	71	66	33	28	---	66 / 71	42	38	47	1400	635	
A12B-300-48V	300	400	3	---	91	86	79	40	33	---	79 / 86	50	46	47	1700	772	
A12B-400-48V	400	600	3	---	121	114	105	53	44	---	105 / 114	66	61	47	1800	817	
130 volt systems (54 through 60L, 92 through 97NC)	A12B-3-130V	3	10	1	7.5	4.3	4.1	3.8	---	---	---	3.8 / 4.1	---	---	3	140	64
	A12B-6-130V	6	15	1	15	8.7	8.2	7.5	---	---	---	7.5 / 8.2	4.7*	---	3	140	64
	A12B-10-130V	10	20	1	26	15	14	13	6.3*	5.2*	---	13 / 14	7.9	7.2	6	225	103
	A12B-15-130V	15	25	1	38	22	21	19	9.4	7.8	---	19 / 21	12	11	6	250	114
	A12B-20-130V	20	30	1	51	29	28	26	13	11	---	26 / 28	16	15	6	270	123
		20	30	3	---	15	14	13	6.5	10	---	13 / 14	8.2	7.5	8A	360	164
	A12B-25-130V	25	35	1	63	37	35	32	16	14	---	32 / 35	20	19	8A	355	161
		25	35	3	---	19	18	16	8.1	13	---	16 / 18	10	9.4	8A	390	177
	A12B-30-130V	30	40	1	75	44	41	38	19	16	---	38 / 41	24	22	8A	390	177
		30	40	3	---	23	21	20	9.8	16	---	20 / 21	12	11	8A	430	196
	A12B-35-130V	35	50	1	88	51	48	44	22	19	---	44 / 48	28	26	72	505	230
		35	50	3	---	27	25	23	12	9.5	---	23 / 25	15	14	72	580	264
	A12B-40-130V	40	60	1	101	58	55	51	26	21	---	51 / 55	32	29	72	550	250
		40	60	3	---	30	29	26	13	11	---	26 / 29	17	16	72	625	284
	A12B-50-130V	50	80	3	---	38	36	33	17	14	---	33 / 36	21	19	72	645	293
	A12B-60-130V	60	80	3	---	46	43	40	20	17	---	40 / 43	25	23	27	865	393
	A12B-75-130V	75	100	3	---	57	54	49	25	21	---	49 / 54	31	29	27	930	422
	A12B-100-130V	100	150	3	---	76	71	66	33	28	---	66 / 71	42	38	27	1040	472
	A12B-125-130V	125	200	3	---	94	89	82	41	34	---	82 / 89	52	48	47	1500	681
	A12B-150-130V	150	200	3	---	113	107	98	49	41	---	98 / 107	62	57	47	1800	817
A12B-175-130V	175	250	3	---	132	125	114	57	48	---	114 / 125	72	66	47	1950	885	
A12B-200-130V	200	250	3	---	151	142	131	66	55	---	131 / 142	83	76	47	2100	953	
A12B-250-130V	250	300	3	---	188	178	163	82	68	---	163 / 178	103	95	47	2300	1044	
A12B-300-130V ⁽³⁾	300	400	3	---	226	214	196	98	82	---	196 / 214	124	113	47B	2400	1089	
A12B-400-130V ⁽³⁾	400	600	3	---	301	285	261	131	109	---	261 / 285	165	151	57	2550	1157	

⁽¹⁾ Optional DC Breaker when ordered in lieu of standard fuse(s) may slightly differ in ratings. AC Draws shown with asterisk * when equipped with AC Breaker, a series fuse is included.
⁽²⁾ AC Current Draws based @ 100% load and standard battery cells of 6L (12V), 12L (24V), 24L (48V) and 60L (130V). Maximum Current Draw is 120% of ratings shown. AC Current draws shown in Italics have high current draws for their specific input voltages - verification of input power requirement should be done prior to ordering. ⁽³⁾ Denotes units not UL Listed
⁽⁴⁾ Case sizes shown are for standard 60Hz units and may differ depending on optional accessories and/or 50Hz input. Please consult factory when dimensions are critical.

Case Specifications

Case No.	Overall Dimensions						Cable Entry (when facing unit)		
	Width		Depth		Height		AC input	DC output	Mounting
	in	mm	in	mm	in	mm			
3	15.375	391	11.000	279	23.750	603	RIGHT	LEFT	WALL / FLOOR
6	25.580	650	13.935	354	28.000	711	RIGHT / TOP / BOTTOM	LEFT / TOP / BOTTOM	WALL / FLOOR
7	14.250	362	10.625	270	19.875	505	RIGHT	LEFT	WALL / FLOOR
8A	27.200	691	15.250	387	32.500	826	RIGHT	LEFT	FLOOR
27	27.312	694	25.875	657	56.125	1426	TOP	TOP	FLOOR
47	38.000	965	39.375	1000	70.000	1778	TOP / BOTTOM	TOP / BOTTOM	FLOOR
47B	38.00	965	46.750	1188	71.125	1807	TOP / BOTTOM	TOP / BOTTOM	FLOOR
57	60.000	1524	36.000	914	80.000	2032	BOTTOM	BOTTOM	FLOOR
70	27.000	686	19.000	483	41.000	1041	RIGHT / BOTTOM	LEFT / BOTTOM	FLOOR
72	27.000	686	23.500	597	44.500	1130	RIGHT / BOTTOM	BOTTOM	FLOOR

Case sizes may differ depending on optional accessories and / or 50Hz input. Please consult factory when dimensions are critical. Dimensions shown above are overall footprint. Detailed dimensions drawings are available for mounting purposes.



46 Series (LCD)



16 Series (LED)

Refer to Digital C.A.P. System Data Sheet for complete details. Discrete alarm LEDs available.

Model Number Nomenclature

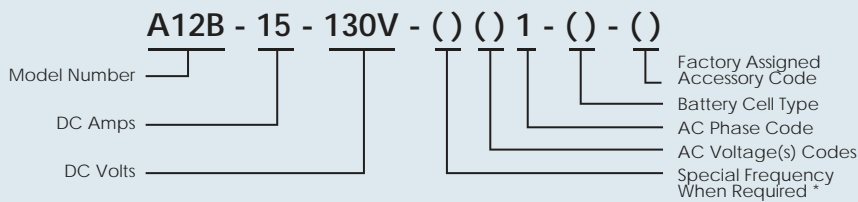

AC Phase Codes

- 1 - Single Phase
- 3 - Three Phase

AC Voltage Codes

- | | |
|-------------|--------------|
| 60Hz | 50Hz |
| A - 120 | BL - 240/220 |
| D - 208 | G - 380 |
| L - 220 | J - 415 |
| B - 240 | |
| C - 480 | |
| ZD - 600 | |

Special Frequency Code

- 5 = 50Hz
- * 60Hz standard unless special code is entered

Battery Cell Type

- L = Lead Acid
- LR = VRLA
- N = Nickel Cadmium

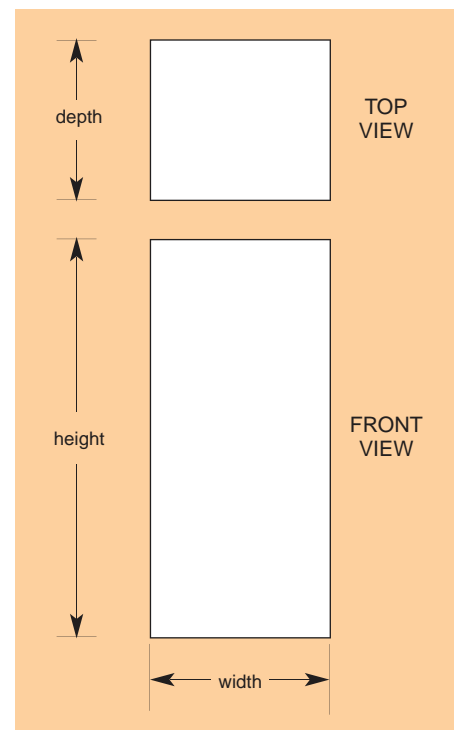

Ordering Information

When ordering, please specify:

- La Marche Model Number A12B
- Input Voltage, Frequency, Phase
- Number and Type of Battery Cells
- Amp Hour Capacity of Battery
- Intermittent DC Loads and Duration
- Continuous DC Load
- Allowable Recharge Time from Full Discharge (where applicable)
- Optional Accessories
- Verify AC Input Current Draw



Standard TPSD with LED Display



TPSD with LCD/VFD Display
(Option 550 / Option 551)



Standard Features

- LED Display
- Automatic DC Voltage Regulation
- Automatic AC Voltage Compensation
- Float/Equalize Mode Switching & LED Indicators (Adjustable FL / EQ voltage levels)
- Equalize Timer - adjustable from 1-144 hours with five selectable modes of operation (manual, automatic every 7, 14 or 30 days and equalize after sensing a low DC voltage)
- Positive and Negative Ground Detection
- AC & DC Surge Protection (MOV's)
- AC Input Circuit Breaker
- AC "ON" LED Indicator
- DC Output Circuit Breaker or Fuse
- Local & Remote Equalize Capability
- Local & Remote Output Voltage Sensing
- Output Load Current Sharing
- Internal Temperature Compensation
- Form "C" Relay Contacts with Adjustable Parameters:
 - Summary Alarm
 - AC Power Failure
 - Low DC Voltage
 - High DC Voltage
 - High DC Voltage Shutdown (HVSD)
 - Low Current
 - Positive and Negative Ground (not adjustable)
- Alarm Indicators:
 - Summary Alarm, Low DC Current, Low DC Voltage, High DC Voltage / HVSD, Ground Detection Fault
- U.L. 1012, C-UL Listed (for all 60Hz Units)
- 5-Year Limited Warranty

**TruPowerSource
Battery Charger / Power Supply**

The La Marche TPSD Battery Charger Series is designed to perform as a Power Supply / Battery Eliminator. This model incorporates Controlled Ferroresonant technology to provide the DC system with a dependable battery charger.

TPSD Battery Charger Series is engineered for the demanding requirements of Switchgear, Process Control, Oil and other DC power applications.

The design of the TPSD utilizes special magnetics that optimizes the performance of the charger. It's known for its High Efficiency, High Power Factor, Low Harmonic Distortion and inherent Current Limiting. The MTBF (Mean Time Between Failure) for this design is conservatively rated at 225,000 hours at 50 C°, assuring longevity and a higher return for your dollar.



LCD Display
(Option 550)



VFD Display
(Option 551)

TPSD with LCD/VFD Display (Option 550/551)

TPSD units equipped with an LCD or VFD display support the same features as standard units plus the following additions:

- 2 Line LCD or VFD Display
- Digital adjustments for the Charger Output (No Potentiometers), Alarms and Communication Settings
- User-Friendly Menu structure with push-button switches for ease of navigation
- Completely Configurable Alarm System
 - Alarm Thresholds
 - Delays
 - Contact Operations (Latching/Non-latching)
- Alarm Contacts testing capability to confirm functionality (Via front panel or remotely with optional communication card)
- Additional LED Indicators
 - AC Power Fail
 - Overload Alarm
 - End of Battery Discharge
 - High Voltage Shutdown
- Quick Start Instructions on the Front Panel with QR Code Link to the Charger's Instruction Manual



Specifications

ELECTRICAL

- **AC Input**
Voltage range: +/- 10% from nominal
Frequency range: +/- 5%
- **Single Phase models:**
A1: 120VAC/1/60Hz
ABD1: 120/240/208VAC/1/60Hz
BLD1: 240/220/208VAC/1/60Hz
C1: 480VAC/1/60Hz
5BL1: 240/220VAC/1/50Hz
- **Three Phase models:**
BD3: 240/208VAC/3/60Hz
C3: 480VAC/3/60Hz
5G3: 380VAC/3/50Hz
- **DC Output**
DC Amps: 6 to 200 amperes
DC Volts: 24, 48 & 130VDC
DC Output Voltage Range - a chart is provided on the last page of this data sheet.
- **Output Filtering (With or without a battery)**
30mV RMS for single phase models and 100mV RMS for three phase models.
- **DC Voltage Regulation Steady-State**
± 0.5% of setting from no load to full load over the specified input voltage, frequency and ambient temperature ranges.
- **Dynamic Response (On Battery)**
Voltage transient < ± 5% over a step change in the load from 20% to 100%. Recovery Time 200 ms.
- **Audible Noise**
Less than 65dBA at any point 5 feet from any vertical surface of the enclosure.
- **Load Sharing**
Load sharing terminal located inside of unit. When connected, identical La Marche Units are forced to share the load within ± 5% for individual unit outputs greater than 15% of the rated output.
- **Temperature Compensation**
5 step curve @ -0.001V/cell/°C as shown below (consult factory for other compensation rates).

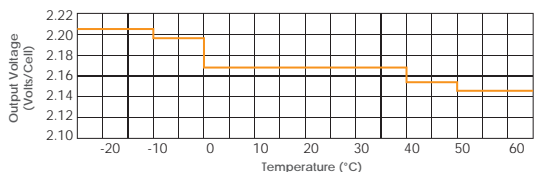

PROTECTION

- **Current Soft Start**
The output current will gradually increase after the charger is turned on, eliminating surges and overshoot.
- **Current Limit**
Electronic Current - Limiting Control Circuitry provides a digitally adjustable limit from 50 to 115% of the rated output current of the charger. Factory set at 115%.
- **DC Breaker & DC Fuse**
Standard units are equipped with a fuse or a 2-pole circuit breaker. For units equipped with a fuse, an optional breaker is available. Refer to the model chart on the next page for further details.
- **AC Breaker**
Single Phase Units:
A two-pole breaker opens both legs of the AC service to 208VAC and 240VAC. Breaker opens phase side of 120VAC service.
Three Phase Units:
A three-pole breaker opens all three legs of the AC service.

REMOTE MONITORING

- Form "C" Alarm Contacts
- With optional Communications Card:
 - Connect to SCADA System
 - Web Monitoring
 - Alarm / Notification E-mails

ENCLOSURES

- **Dimensions**
Overall dimensions and weights are subject to change due to innovative product development and design. When space requirements are critical, please consult the factory.
- **Mounting**
Our enclosures are very versatile. Some units can be wall, floor or rack mounted and others can be wall or floor mounted. See the Case Specifications Chart on the last page of this data sheet for further details.

ENCLOSURES

- **Finish**
Pretreated with a seven stage iron phosphate wash, sealer and deionized rinse. Then coated with an environmentally safe and durable ANSI 61 gray Polyester TGIC Minite powder finish.

ENVIRONMENTAL

- **Operating Temperature**
0 to 50°C
- **Storage Temperature**
-40 to 85°C
- **Humidity**
0 to 95% Relative Humidity (Non-Condensing)
- **Cooling**
Convection cooled

Optional Accessories

- 550 Digital Controller with LCD Display
- 551 Digital Controller with VFD Display
- 017 DC Breaker 2-Pole (Standard on some units) see chart on pg. 3 for further details.
- 01C 2-Pole High Interrupting Capacity AC Breaker 65KAIC 240 VAC. Only available for units with current draws above 8 amps.
- 01D 2-Pole High Interrupting Capacity AC Breaker 65KAIC 480 VAC. Only available for units with current draws above 8 amps.
- 01G 3-Pole High Interrupting Capacity AC Breaker 65KAIC 480 VAC. Only available for units with current draws above 8 amps.
- 05C DC Current Transducer
- 206 DC Voltage Transducer
- 102 Blocking Diode
- 11W External Temperature Probe 22ft
- 11Y External Temperature Probe 100ft
- 11L Lightning Arrestor
- 09C I.D. Tags - White text on black background
- 09V I.D. Tags - Black text on white background
- 09W Heat Shrink Wire Markers with Electrical Schematic
- 38G ABS Type Approval
- 07V 4C Case (Pending UL Listing)
- 537 OSHPD Certification Label (consult factory for Anchor Kits)
- 538 IBC Certification Label (consult factory for Anchor Kits)

Communication Protocols

- 21J IEC 61850
- 21P DNP 3.0 Communications RS232/RS485/Ethernet
- 21Q Modbus Communications RS232/RS485/Ethernet
- 21S Modbus RTU - Serial Data Port
- 21X SNMP



Standard LED Display

TABLE OF CONTENTS

TPSD Charger Chart

1-Phase																				
Model Number	DC Amps	DC Protection		60Hz									50Hz ⁽³⁾				Heat Loss ⁽⁴⁾ BTU's/ Hour	Case No.		
				AC Current Draw ⁽¹⁾ Recommended Feeder AC Supply Breaker						Shipping Weight		AC Current Draw ⁽¹⁾ Feeder AC Supply Breaker		Shipping Weight						
		DC Fuse	DC Breaker/ Rating	A1 120	ABD1 120/240/208	BLD1 240/220/208	Feeder** Breaker Size	Rating	C1 480V	Feeder** Breaker Size	Rating	lbs	kgs	5BL1 240/220	Feeder** Breaker Size	lbs			kgs	
24V ⁽²⁾ (12L or 20NC)	TPSD-6-24V	6	---	10 / 7.5KAIC	2	---	---	5	2KAIC	---	---	---	90	40.8	---	---	---	---	119	4B***
	TPSD-12-24V	12	---	15 / 7.5KAIC	4	---	---	10	2KAIC	---	---	---	90	40.8	---	---	---	---	238	4B***
	TPSD-20-24V	20	---	30 / 7.5KAIC	---	6.7 / 3.4 / 3.9	---	10 / 5 / 5	5KAIC	---	---	---	100	45.4	3.4 / 3.7	5 / 5	110	49.8	396	4
	TPSD-25-24V	25	---	40 / 7.5KAIC	---	8.4 / 4.2 / 4.9	---	15 / 10 / 10	5KAIC	---	---	---	125	56.7	4.2 / 4.6	10 / 10	138	62.6	495	4
	TPSD-30-24V	30	---	40 / 7.5KAIC	---	11 / 5 / 5.8	---	15 / 10 / 10	5KAIC	---	---	---	150	68.0	5.0 / 5.5	10 / 10	165	74.8	405	4
	TPSD-35-24V	35	---	50 / 7.5KAIC	---	12 / 5.9 / 6.8	---	20 / 10 / 10	5KAIC	---	---	---	154	69.9	5.9 / 6.4	10 / 10	170	77.1	472	4
	TPSD-50-24V	50	---	70 / 7.5KAIC	---	17 / 8.4 / 9.7	---	30 / 15 / 15	5KAIC	---	---	---	175	79.4	8.4 / 9.2	15 / 15	193	87.5	674	4
	TPSD-75-24V	75	---	100 / 7.5KAIC	---	26 / 13 / 15	---	40 / 20 / 20	5KAIC	6.3	10	5KAIC	211	95.7	13 / 14	20 / 20	233	105.7	1011	4
TPSD-100-24V	100	130	Optional*	---	34 / 17 / 20	---	40 / 20 / 20	5KAIC	8.4	15	5KAIC	225	102.1	17 / 19	25 / 25	248	112.5	1347	9	
48V ⁽²⁾ (24L or 37NC)	TPSD-6-48V	6	---	10 / 7.5KAIC	4	---	---	10	2KAIC	---	---	---	90	40.8	---	---	---	---	191	4B***
	TPSD-12-48V	12	---	15 / 7.5KAIC	8.1	---	---	15	2KAIC	---	---	---	110	49.9	---	---	---	---	382	4B***
	TPSD-20-48V	20	---	30 / 7.5KAIC	---	14 / 6.7 / 7.8	---	20 / 10 / 10	5KAIC	---	---	---	150	68.0	6.7 / 7.3	10 / 10	165	74.8	637	4
	TPSD-25-48V	25	---	40 / 7.5KAIC	---	17 / 8.4 / 9.7	---	30 / 15 / 15	5KAIC	---	---	---	150	68.0	8.4 / 9.2	15 / 15	165	74.8	796	4
	TPSD-30-48V	30	---	40 / 7.5KAIC	---	21 / 11 / 12	---	30 / 15 / 15	5KAIC	---	---	---	155	70.3	11 / 11	15 / 15	171	77.6	601	4
	TPSD-35-48V	35	---	50 / 7.5KAIC	---	24 / 12 / 14	---	40 / 20 / 20	5KAIC	5.9	10	5KAIC	180	81.7	12 / 13	20 / 20	198	89.8	702	4
	TPSD-50-48V	50	---	70 / 7.5KAIC	---	34 / 17 / 20	---	40 / 20 / 20	5KAIC	8.4	15	5KAIC	205	93.0	17 / 19	25 / 25	225	102.1	1002	4
	TPSD-75-48V	75	---	100 / 7.5KAIC	---	51 / 26 / 30	---	70 / 35 / 35	5KAIC	13	20	5KAIC	295	133.8	26 / 28	40 / 40	325	147.4	1503	9
TPSD-100-48V	100	130	Optional*	---	---	34 / 37 / 39	50 / 50 / 50	5KAIC	17	25	5KAIC	321	145.6	34 / 37	50 / 50	354	160.6	2004	9	
130V ⁽²⁾ (58L or 60L 92NC or 96NC)	TPSD-6-130V	6	---	10 / 5KAIC	---	11 / 5 / 5.8	---	20 / 10 / 10	5KAIC	---	---	---	140	63.5	5.0 / 5.5	10 / 10	154	69.9	478	4
	TPSD-12-130V	12	---	15 / 10KAIC	---	21 / 11 / 12	---	30 / 15 / 15	5KAIC	---	---	---	175	79.4	11 / 11	15 / 15	193	87.5	955	4
	TPSD-20-130V	20	---	30 / 10KAIC	---	34 / 17 / 20	---	50 / 25 / 25	5KAIC	8.4	15	5KAIC	225	102.1	17 / 19	25 / 25	233	105.7	1591	4
	TPSD-25-130V	25	---	40 / 10KAIC	---	42 / 21 / 25	---	60 / 30 / 30	5KAIC	11	15	5KAIC	250	113.4	21 / 23	30 / 30	275	124.7	1989	4
	TPSD-30-130V	30	---	40 / 10KAIC	---	51 / 26 / 30	---	60 / 30 / 30	5KAIC	13	15	5KAIC	319	144.7	26 / 28	40 / 40	352	159.7	1503	9
	TPSD-35-130V	35	---	50 / 10KAIC	---	59 / 30 / 34	---	80 / 40 / 40	5KAIC	15	20	5KAIC	372	168.7	30 / 33	45 / 45	410	186	1753	9
	TPSD-50-130V	50	---	70 / 10KAIC	---	---	---	42 / 46 / 49	60 / 60 / 70	5KAIC	21	25	5KAIC	532	241.3	42 / 46	60 / 60	586	265.8	2504

* Optional DC Breaker is rated at 10KAIC.
 ** Recommended Breaker Size
 *** Also available in 4C case

3-Phase																				
Model Number	DC Amps	DC Protection		60Hz									50Hz ⁽³⁾				Heat Loss ⁽⁴⁾ BTU's/ Hour	Case No.		
				AC Current Draw ⁽¹⁾ Recommended Feeder AC Supply Breaker						Shipping Weight		AC Current Draw ⁽¹⁾ Feeder AC Supply Breaker		Shipping Weight						
		DC Fuse	DC Breaker/ Rating	BD3 240/208V	Feeder** Breaker Size	Rating	C3 480	Feeder** Breaker Size	Rating	lbs	kgs	5G3 380V	Feeder** Breaker Size	lbs	kgs					
24V ⁽²⁾ (12L or 20NC)	TPSD-75-24V	75	---	100 / 7.5KAIC	6.3 / 7.3	10 / 10	5KAIC	---	---	---	400	181.4	---	---	---	---	752	72		
	TPSD-100-24V	100	130	Optional*	8.5 / 9.8	15 / 15	5KAIC	---	---	---	475	215.5	---	---	---	---	1002	72		
	TPSD-150-24V	150	200	Optional*	13 / 15	20 / 20	5KAIC	6.3	15	5KAIC	530	240.4	---	---	---	---	1503	72		
	TPSD-200-24V	200	250	Optional*	17 / 20	25 / 25	5KAIC	8.5	15	5KAIC	600	272.2	---	---	---	---	2004	72		
48V ⁽²⁾ (24L or 37NC)	TPSD-50-48V	50	---	70 / 7.5KAIC	8.5 / 9.8	15 / 15	5KAIC	---	---	---	400	181.4	---	---	---	---	1002	72		
	TPSD-75-48V	75	---	100 / 7.5KAIC	13 / 15	25 / 25	5KAIC	6.3	10	5KAIC	575	260.8	---	---	---	---	1503	72		
	TPSD-100-48V	100	130	Optional*	17 / 20	30 / 30	5KAIC	8.5	15	5KAIC	600	272.2	---	---	---	---	2004	72		
	TPSD-150-48V	150	200	Optional*	26 / 30	40 / 40	5KAIC	13	20	5KAIC	700	317.5	---	---	---	---	3005	72		
TPSD-200-48V	200	250	Optional*	34 / 40	60 / 60	5KAIC	17	25	5KAIC	755	342.5	---	---	---	---	4007	72			
130V ⁽²⁾ (58L or 60L 92NC or 96NC)	TPSD-25-130V	25	---	40 / 10KAIC	11 / 13	20 / 20	5KAIC	---	---	---	420	190.5	---	---	---	---	1252	72		
	TPSD-30-130V	30	---	40 / 10KAIC	13 / 15	20 / 20	5KAIC	6.3	10	5KAIC	490	222.3	---	---	---	---	1503	72		
	TPSD-35-130V	35	---	50 / 10KAIC	15 / 18	25 / 25	5KAIC	7.4	10	5KAIC	550	249.5	---	---	---	---	1753	72		
	TPSD-50-130V	50	---	70 / 10KAIC	22 / 25	35 / 35	5KAIC	11	20	5KAIC	600	272.2	---	---	---	---	2504	72		
	TPSD-75-130V	75	100	Optional*	32 / 37	50 / 50	5KAIC	16	25	5KAIC	660	299.4	20	30	727	329.8	3756	72		
	TPSD-100-130V	100	130	Optional*	43 / 49	70 / 70	5KAIC	22	30	5KAIC	800	362.9	27	35	882	400.1	5008	72		
	TPSD-125-130V ⁽³⁾	125	200	Optional*	53 ⁽³⁾ / 61 ⁽³⁾	80 / 80	5KAIC	27 ⁽³⁾	40	5KAIC	850	385.6	---	---	---	---	6260	44		
TPSD-150-130V ⁽³⁾	150	200	Optional*	64 ⁽³⁾ / 74 ⁽³⁾	100 / 100	5KAIC	32 ⁽³⁾	45	5KAIC	900	408.2	---	---	---	---	7512	44			

* Optional DC Breaker is rated at 10KAIC.
 ** Recommended Breaker Size

⁽¹⁾ AC Current Draws based @ 100% load and standard battery cells of 12L (24V), 24L (48V) and 60L (130V). Maximum Current Draw is 115% of ratings shown.
⁽²⁾ Must specify only one battery type and number of cells from range shown above. Please consult factory for other available cell ranges if desired range not shown.
⁽³⁾ Not UL Listed
⁽⁴⁾ BTU's are based on 12L (24V), 24L (48V) and 60L (130V). Heat loss is stated for nominal float voltage, 100% output current and nominal AC line.

TABLE OF CONTENTS

Case Specifications

Case No.	Overall Dimensions					
	Width		Depth		Height	
	in	mm	in	mm	in	mm
4B*	19.000	483	15.000	381	12.250*	311*
4C*	15.000	381	11.000	280	24.000*	610*
4*	19.000	483	15.000	381	24.000*	610*
9*	23.000	584	15.000	381	36.000*	914*
72	27.000	686	23.500	597	44.500	1130
44	24.000	610	19.000	483	72.100	1831

Case No.	Cable Entry (when facing unit)		Mounting
	AC input	DC output	
4B*	RIGHT TOP / BOTTOM / SIDE	LEFT TOP / BOTTOM	19/23" RACK, WALL/ FLOOR
4C*	RIGHT TOP / BOTTOM	LEFT TOP / BOTTOM / SIDE	WALL/ FLOOR
4*	RIGHT TOP/ BOTTOM	LEFT TOP / BOTTOM / SIDE	19/23" RACK, WALL / FLOOR
9*	RIGHT TOP / BOTTOM / SIDE	TOP / BOTTOM	23" RACK, WALL / FLOOR
72	RIGHT / BOTTOM / SIDE	BOTTOM	FLOOR
44	TOP LEFT	TOP RIGHT	FLOOR

*Floor mounting brackets add 2" (51mm) to overall height. Case sizes may differ depending on optional accessories. Consult factory when dimensions are critical. Detailed dimensional drawings are available for mounting purposes.

Adjustable DC Output Voltage Range

	Battery Cell Type Code	Float		Equalize	
		Min	Max	Min	Max
24V	12L	25.44	27.60	27.00	28.80
	20N	27.80	29.00	30.00	32.00
48V	24L	50.88	55.20	54.00	57.60
	37N	51.43	53.65	55.50	59.20
130V	58L	122.96	133.40	130.50	139.20
	60L	127.20	138.00	135.00	144.00
	92N	127.88	133.40	138.00	147.20
	96N	133.44	139.20	144.00	153.60

Battery Charger Sizing Guidelines

- Required Battery Backup Time (Hours)
- DC Output Voltage
- Ampere Hour Capacity of Battery
- Allowable Recharge Time From Full Discharge (Hours), Where Applicable
- Continuous and Intermittent DC Loads and Duration (Amps)

Model Number Nomenclature

TPSD - 25 - 130V - () () () - () - ()

Model Number ———

DC Amps ———

DC Volts ———

Factory Assigned Accessory Code

Battery Cell Range

AC Phase Code

AC Voltage(s) Code(s)

Special Frequency When Required **

**Special Frequency Code	AC Voltage Codes	AC Phase Codes	Battery Cell Type Code
5 - 50Hz	A - 120	1 - Single Phase	12L 20N 12LR
60Hz standard unless special code is entered	C - 480	3 - Three Phase	24L 37N 24LR
	G - 380		58L 92N 58LR
	BD - 240/208		60L 96N 60LR
	BL - 240/220		
	ABD - 120/240/208		L = Lead Acid
	BLD - 240/220/208		N = Nickel Cadmium
			LR = VRLA

Ordering Information

When ordering, please specify:

- La Marche Model Number TPSD
- DC Amps
- DC Volts
- Special Frequency, When Required
- AC Voltage Code
- AC Phase Code
- Battery Cell Type Code
- Optional Accessories (Option Code)



“Constavolt”

Marine Battery Charger

The La Marche model A41/A41F battery chargers are renowned throughout the industry like the Constavolt because of their reliability and their precise and constant output voltage to charge your batteries. These battery chargers can supply DC power for all ship board accessories while they simultaneously charge and keep your vessel batteries properly maintained. A wide range of A41/A41F Constavolt models are offered from 12 to 130 Volts DC to suit your needs. The Constavolt is a completely automatic, solid state, constant voltage battery charger built to carry continuous and intermittent loads up to 80% of its maximum rated output capacity.

Standard Features

- Magnetic Amplifier Circuitry
- Automatic DC Voltage Regulation
- Automatic AC Input Voltage Compensation +/- 10%
- Dual AC input and DC output fusing protects battery and charger
- Analog DC Ammeter
- DC Current Limiting Circuitry
- Charger design prevents battery from discharging if AC line fails
- AC to DC Isolation
- Model A41F is filtered for Valve-Regulated batteries
- USCG (United States Coast Guard) Accessories include a drip shield, On/Off switch & water tight connectors
- UL 1236 Listed
- 10-Year Limited Warranty

Environmental

- Operating Temperature: 0 to 50° C (32 to 122° F)
Storage Temperature: -40 to 85° C (-40 to 185° F)
Relative Humidity: 0 to 95% non-condensing

TABLE OF CONTENTS

A41 / A41F Models

	Model Number All Models Available As A41F	DC Output			AC Input Current Draw* at 100% Load (Amps)			A41 Case No.	A41 Shipping Weight (Approximate)		A41F Case No.	A41F Shipping Weight (Approximate)	
		Amps	Volts	Fuse Size	A 120	D 208	B 240		lbs	kgs		lbs	kgs
12VDC 6L, 9 or 10NC	A41-10-12V	10	12V	20A	2.5	1.4	1.3	05	33	15.0	2	49	22.3
	A41-20-12V	20	12V	35A	5	2.9	2.5	2	57	25.9	7	69	31.4
	A41-30-12V	30	12V	50A	7.5	4.3	3.8	2	68	30.9	3	93	42.3
	A41-40-12V	40	12V	70A	10	5.8	5	2	78	35.5	4	137	62.3
	A41-60-12V	60	12V	100A	15	8.7	7.5	7	104	47.3	6	174	79.1
	A41-75-12V ⁽¹⁾	75	12V	130A	19	11	9.4	3	130	59.1	6	194	88.2
	A41-100-12V ⁽¹⁾	100	12V	150A	26	15	13	6	180	81.8	8A	225	102.3
24VDC 12L, 19 or 20NC	A41-10-24V	10	24V	20A	5	2.9	2.5	2	64	29.1	7	76	34.5
	A41-20-24V	20	24V	35A	10	5.8	5	2	76	34.5	7	88	40.0
	A41-30-24V	30	24V	50A	15	8.7	7.5	7	104	47.3	3	123	55.9
	A41-40-24V	40	24V	70A	21	12	10	7	146	66.4	3	177	80.5
	A41-60-24V	60	24V	100A	31	18	15	3	200	90.9	4	263	119.5
	A41-75-24V ⁽¹⁾	75	24V	130A	38	22	19	3	278	126.4	6	319	145.0
32VDC 16L	A41-10-32V	10	32V	20A	6.7	3.9	3.3	2	70	31.8	7	82	37.3
	A41-20-32V	20	32V	35A	14	7.7	6.7	2	75	34.1	3	93	42.3
	A41-30-32V	30	32V	50A	21	12	10	7	102	46.4	3	121	55.0
	A41-40-32V	40	32V	70A	27	16	14	3	190	86.4	4	237	107.7
	A41-60-32V	60	32V	100A	41	24	21	3	225	102.3	6	289	131.4
130 VDC 60L / 92N	A41-10-130V	10	130V	20A	26	15	13	3	165	75.0	4	183	87.7
	A41-20-130V	20	130V	35A	51	29	26	6	185	84.1	6	191	86.8

All above models designed for optimal performance at 60Hz. They will operate at 50Hz with reduced performance. Consult factory for units designed specifically at 50Hz. Please consult factory for other available cell ranges if desired range not shown. *AC Current Draws based @ 100% load and standard battery cells of 6L(12V),12L(24V),16L(32V),60L(130V). Maximum Current Draw is typically 140% of ratings shown.

(1) Units Not UL Listed.

Case Specifications

Case No.	Overall Dimensions						Cable Entry (when facing unit)		Mounting
	Width		Depth		Height		AC input	DC output	
	in	mm	in	mm	in	mm			
05	8.000	203	7.000	178	13.000	330	BOTTOM RIGHT	BOTTOM RIGHT	WALL
1	10.375	264	7.875	200	16.250	413	RIGHT	LEFT	WALL
2	12.812	326	10.000	254	17.125	435	RIGHT	LEFT	WALL
3	15.375	391	11.000	279	23.750	603	RIGHT	LEFT	WALL/FLOOR
4	19.000	483	15.000	381	25.875	657	RIGHT/TOP/BOTTOM	LEFT/TOP/BOTTOM	WALL/FLOOR/RACK
6	25.580	650	13.935	354	28.000	711	RIGHT/TOP/BOTTOM	LEFT/TOP/BOTTOM	WALL/FLOOR
7	14.250	362	10.625	270	19.875	505	RIGHT	LEFT	WALL/FLOOR
8A	27.200	691	15.250	387	32.500	826	RIGHT	LEFT	FLOOR

Case sizes may differ depending on optional accessories. Please consult factory when dimensions are critical. Dimensions shown above are overall footprint. Detailed dimension drawings are available for mounting purposes.

Model Number Nomenclature

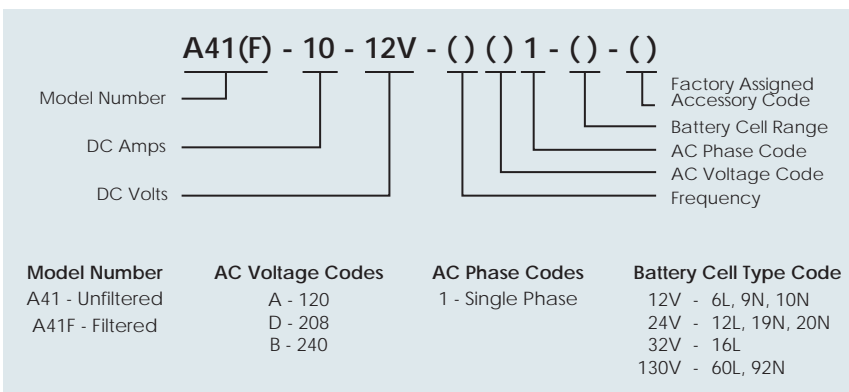

Optional External Charge Dividers

Model Number	Number of Batteries	DC Range		Case No.	Shipping Weight (Approximate)	
		Amps	Volts		lbs	kgs
CD40-20/30-12/32-N2	2	10-30	12-32	05	10	4.5
CD40-20/30-12/32-N3	3	10-30	12-32	05	11	5.0
CD40-40/60-12/32-N2	2	40-60	12-32	1	14	6.4
CD40-40/60-12/32-N3	3	40-60	12-32	1	15	6.8
CD40-75/100-12/32-N2	2	75-100	12-32	2	23	10.4
CD40-75/100-12/32-N3	3	75-100	12-32	2	25	11.3

Note: All above models are configured for Negative Common. For Positive Common, part number changes as follow: CD40-20/30-12/32-P2.

Optional Internal Charge Dividers

- 100 To charge 2 batteries with a negative common
- 10U To charge 2 batteries with a positive common
- 101 To charge 3 batteries with a negative common
- 10V To charge 3 batteries with a positive common

Note: Consult factory may increase case size.

Battery Charger Sizing Guidelines

- Required Battery Backup Time (Hours)
- DC Output Voltage
- Ampere Hour Capacity of Battery
- Allowable Recharge Time From Full Discharge (Hours), Where Applicable
- Continuous and Intermittent DC Loads (Amps) and Duration (Time)

Ordering Information When ordering, please specify:

- La Marche Model Number A41 or A41F
- DC Amps
- DC Volts
- Special Frequency, When Required
- AC Voltage Code
- AC Phase Code
- Battery Cell Type Code
- Optional Accessories (Option Code)



“Constavolt”

Engine Starting Battery Charger

The La Marche model A40/A40F battery chargers are renowned throughout the industry as the Constavolt because of their reliability and their precise and constant output voltage to charge your batteries. The Constavolt is a completely automatic, solid state, constant voltage battery charger built to carry continuous and intermittent loads up to 80% of its maximum rated output capacity. It is ideal for applications where it is advantageous to have the charger permanently connected across the battery, keeping it charged at all times and to simultaneously carry continuous and/or intermittent current loads such as onboard peripheral equipment.

Standard Features

- Magnetic Amplifier Circuitry
- Automatic DC Voltage Regulation
- Automatic AC Input Voltage Compensation +/- 10%
- Automatic Surge Suppression
- AC input and DC output fusing protects battery and charger
- Analog DC Ammeter
- DC Current Limiting Circuitry
- Charger design prevents battery from discharging if AC line fails
- AC to DC Isolation
- Model A40F is filtered for Valve-Regulated batteries
- A40/A40F models are UL 1564 Listed & C-UL Listed
- 10-Year Limited Warranty

Environmental

- Operating Temperature: 0 to 50° C (32 to 122° F)
- Storage Temperature: -40 to 85° C (-40 to 185° F)
- Relative Humidity: 0 to 95% non-condensing

TABLE OF CONTENTS

A40 / A40F Models

	Model Number All Models Available As A40F	DC Output			AC Input Current Draw* at 100% Load (Amps)			A40 Case No.	A40 Shipping Weight (Approximate)		A40F Case No.	A40F Shipping Weight (Approximate)	
		Amps	Volts	Fuse Size	A 120	D 208	B 240		lbs	kgs		lbs	kgs
12VDC 6L, 9 or 10NC	A40-10-12V	10	12V	20A	2.5	1.4	1.3	05	30	13.6	2	46	20.9
	A40-20-12V	20	12V	35A	5	2.9	2.5	2	54	24.5	7	66	30.0
	A40-30-12V	30	12V	50A	7.5	4.3	3.8	2	65	29.5	3	90	40.9
	A40-40-12V	40	12V	70A	10	5.8	5	2	74	33.6	4	133	60.5
	A40-60-12V	60	12V	100A	15	8.7	7.5	7	98	44.5	6	168	76.4
	A40-75-12V	75	12V	130A	19	11	9.4	3	123	55.9	6	187	85.0
	A40-100-12V	100	12V	150A	26	15	13	6	165	75.0	8A	260	118.2
24VDC 12L, 19 or 20NC	A40-10-24V	10	24V	20A	5	2.9	2.5	2	61	27.7	7	73	33.2
	A40-20-24V	20	24V	35A	10	5.8	5	2	72	32.7	7	84	38.2
	A40-30-24V	30	24V	50A	15	8.7	7.5	7	98	44.5	3	117	53.2
	A40-40-24V	40	24V	70A	21	12	10	7	105	47.7	3	136	61.8
	A40-60-24V	60	24V	100A	31	18	15	3	150	68.2	4	213	96.8
	A40-75-24V	75	24V	130A	38	22	19	3	210	95.5	6	274	124.5
	A40-100-24V	100	24V	150A	51	29	26	8A	300	136.4	8A	374	170.0
32VDC 16L	A40-10-32V	10	32V	20A	6.7	3.9	3.3	2	61	27.7	7	73	33.2
	A40-20-32V	20	32V	35A	14	7.7	6.7	2	72	32.7	3	90	40.9
	A40-30-32V	30	32V	50A	21	12	10	7	98	44.5	3	117	53.2
	A40-40-32V	40	32V	70A	27	16	14	3	140	63.6	4	187	85.0
	A40-60-32V	60	32V	100A	41	24	21	3	170	77.3	6	234	106.4
	A40-75-32V	75	32V	130A	51	29	26	8A	250	113.6	8A	291	132.3
130 VDC 60L / 92NC	A40-10-130V	10	130V	20A	26	15	13	3	155	70.5	4	183	83.2
	A40-20-130V	20	130V	35A	51	29	26	6	175	79.5	6	181	82.3
	A40-30-130V	30	130V	50A	76	44	38	8A	330	150.0	8A	343	155.9

All above models designed for optimal performance at 60Hz. They will operate at 50Hz with reduced performance. Consult factory for units designed specifically at 50Hz. Please consult factory for other available cell ranges if desired range not shown. *AC Current Draws based @100% load and standard battery cells of 6L(12V),12L(24V),16L(32V),60L(130V). Maximum Current Draw is typically 140% of ratings shown.

Case Specifications

Case No.	Overall Dimensions						Cable Entry (when facing unit)		Mounting
	Width		Depth		Height		AC input	DC output	
	in	mm	in	mm	in	mm			
05	8.000	203	7.000	178	13.000	330	BOTTOM RIGHT	BOTTOM RIGHT	WALL
1	10.375	264	7.875	200	16.250	413	RIGHT	LEFT	WALL
2	12.812	326	10.000	254	17.125	435	RIGHT	LEFT	WALL
3	15.375	391	11.000	279	23.750	603	RIGHT	LEFT	WALL/FLOOR
4	19.000	483	15.000	381	25.875	657	RIGHT/TOP/BOTTOM	LEFT/TOP/BOTTOM	WALL/FLOOR/RACK
6	25.580	650	13.935	354	28.000	711	RIGHT/TOP/BOTTOM	LEFT/TOP/BOTTOM	WALL/FLOOR
7	14.250	362	10.625	270	19.875	505	RIGHT	LEFT	WALL/FLOOR
8A	27.200	691	15.250	387	32.500	826	RIGHT	LEFT	FLOOR

Case sizes may differ depending on optional accessories. Please consult factory when dimensions are critical. Dimensions shown above are overall footprint. Detailed dimension drawings are available for mounting purposes.

Model Number Nomenclature

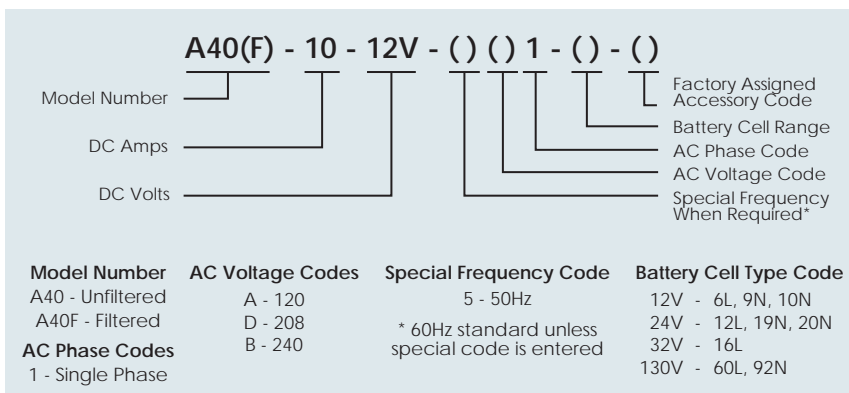

Optional External Charge Dividers

Model Number	Number of Batteries	DC Range		Case No.	Shipping Weight (Approximate)	
		Amps	Volts		lbs	kgs
CD40-20/30-12/32-N2	2	10-30	12-32	05	10	4.5
CD40-20/30-12/32-N3	3	10-30	12-32	05	11	5.0
CD40-40/60-12/32-N2	2	40-60	12-32	1	14	6.4
CD40-40/60-12/32-N3	3	40-60	12-32	1	15	6.8
CD40-75/100-12/32-N2	2	75-100	12-32	2	23	10.4
CD40-75/100-12/32-N3	3	75-100	12-32	2	25	11.3

Note: All above models are configured for Negative Common. For Positive Common, part number changes as follows: CD40-20/30-12/32-P2.

Optional Internal Charge Dividers

- 100 To charge 2 batteries with a negative common
- 10U To charge 2 batteries with a positive common
- 101 To charge 3 batteries with a negative common
- 10V To charge 3 batteries with a positive common

Note: Consult factory may increase case size.

Battery Charger Sizing Guidelines

- Required Battery Backup Time (Hours)
- DC Output Voltage
- Ampere Hour Capacity of Battery
- Allowable Recharge Time From Full Discharge (Hours), Where Applicable
- Continuous and Intermittent DC Loads (Amps) and Duration (Time)

Ordering Information When ordering, please specify:

- La Marche Model Number A40 or A40F
- DC Amps
- DC Volts
- Special Frequency, When Required
- AC Voltage Code
- AC Phase Code
- Battery Cell Type Code
- Optional Accessories (Option Code)

Engine Starting Battery Charger



Standard



16 Series CAP



46 Series CAP



The La Marche A46/A46F battery charger is specially designed for maintaining and recharging starting batteries of engine generator sets. The controlled magnetic amplifier technology provides the highest reliability that is necessary for the continued operation of the emergency standby equipment and eliminates most starting problems by maintaining batteries at a proper charge, ensuring optimum performance and maximum life.

These chargers can also be customized to meet the American Bureau of Shipping (ABS) and United States Coast Guard (USCG) standards for applications such as offshore and on board vessels.

Standard Features

- Magnetic Amplifier Circuitry
- Automatic DC Voltage Regulation
- Automatic AC Input Voltage Compensation +/- 10%
- Automatic Surge Suppression
- Analog DC Ammeter & DC Voltmeter
- DC Current Limiting Circuitry
- AC Input and DC Output Fusing
- AC Power Failure Relay with (1) set of Form "C" Contacts
- Float/Equalize Mode Switching
- Charger design prevents battery from discharging if AC line fails
- AC to DC Isolation
- Model A46F is filtered for Valve-Regulated batteries
- UL 1564 Listed and C-UL Listed
- 10-Year Limited Warranty



A46 & A46F Models

Model Number All Models Available As A46F	DC Output			AC Input Current Draw* at 100% Load (Amps)				A46 Case No.	A46 Shipping Weight (Approximate)		A46F Case No.	A46F Shipping Weight (Approximate)		
	Amps	Volts	Fuse Size	A 120	D 208	B 240	C 480		lbs	kgs		lbs	kgs	
12VDC 6L, 9 or 10NC	A46-6-12V	6	12V	15A	1.5	0.9	0.8	--	1	28	12.7	2	39	17.8
	A46-10-12V	10	12V	20A	2.5	1.4	1.3	--	1	30	13.6	2	41	18.7
	A46-20-12V	20	12V	35A	5	2.9	2.5	--	2	56	25.4	7	68	31.0
	A46-30-12V	30	12V	50A	7.5	4.3	3.8	--	2	66	29.9	3	91	41.4
24VDC 12L, 19 or 20NC	A46-6-24V	6	24V	15A	3	1.7	1.5	--	1	38	17.2	7	50	22.8
	A46-10-24V	10	24V	20A	5	2.9	2.5	--	2	62	28.1	7	74	33.7
	A46-20-24V	20	24V	35A	10	5.8	5	--	2	73	33.1	7	85	38.7
	A46-30-24V	30	24V	50A	15	8.7	7.5	--	7	108	49.0	3	127	57.8
	A46-40-24V	40	24V	70A	21	12	10	--	7	112	50.8	3	143	65.0
	A46-50-24V	50	24V	80A	26	14.6	13	6.5	3	140	63.5	4	148	67.1
32VDC 16L	A46-6-32V	6	32V	15A	4	2.3	2	--	2	58	26.3	7	70	31.9
	A46-10-32V	10	32V	20A	6.7	3.9	3.3	--	2	68	30.8	7	80	36.4
	A46-20-32V	20	32V	35A	14	7.7	6.7	--	2	74	33.6	3	92	41.9
	A46-30-32V	30	32V	50A	21	12	10	--	7	112	50.8	3	131	59.6
36VDC 18L	A46-6-36V	6	36V	15A	4.5	2.7	2.4	--	2	58	26.3	7	70	31.9
	A46-10-36V	10	36V	20A	7.5	4.2	3.9	--	2	68	30.9	7	80	36.4
	A46-20-36V	20	36V	35A	15	8.7	7.5	--	7	74	33.6	3	92	41.9
	A46-30-36V	30	36V	50A	22.5	12.9	11.4	--	7	112	50.8	3	131	59.6

Case Specifications

Case No.	Overall Dimensions Width x Depth x Height
1	10" x 8" x 16" 264 x 200 x 413mm
2	13" x 10" x 17" 326 x 254 x 435mm
3	15" x 11" x 24" 391 x 279 x 603mm
4	19" x 15" x 26" 483 x 381 x 658mm
7	14" x 11" x 20" 362 x 270 x 505mm

Note: All above models designed for optimal performance at 60Hz. They will operate at 50Hz with reduced performance. Consult factory for units designed specifically at 50Hz. Must specify only one battery type and number of cells. Please consult factory for other available cell ranges if desired range not shown.
*AC Current Draws based @ 100% load using standard battery cells of 6L(12V), 12L(24V), 18L(36V)
Maximum current Draw is typically 140% of ratings shown.

Options

Circuit Breakers

- **011** AC Breaker Single Pole (120VAC only)
- **012** DC Breaker Single Pole
- **016** AC Breaker Two Pole
- **017** DC Breaker Two Pole

Choose options from Discrete or Combination Accessory Packages (C.A.P.)

Discrete

(Choose one or more of the options in this category)

- **055** Float Light
- **056** Equalize Light
- **060** AC Pilot Light
- **04J** Multi-Mode Equalize Timer & Lights
Adjustable from 1-144hrs in (5) selectable modes; Standard, 7-day, 14-day, 30-day and Equalize after Low DC Voltage. Includes Float and Equalize Lights (055 and 056)

Combination Accessory Packages (C.A.P.)

- **16E** Digital C.A.P. system (Meets NFPA 110)
Features a selectable LED display along with the AC Pilot Light, Equalize Timer and many more features (Refer to the Digital C.A.P. System data sheet for complete details).
- **16J** Digital C.A.P. System (Meets NFPA 110)
Includes all the features of 16E package (above) plus Ground Detection Alarm (Refer to the Digital C.A.P. System data sheet for complete details).
- **46E** LCD C.A.P. system (Meets NFPA 110)
Features Selectable Display, Multi-Mode Equalize Timer, Equalize light, Float Light and many more features (Refer to the Digital LCD System data sheet for complete details).
- **46J** LCD C.A.P. system (Meets NFPA 110)
Includes all the features of 46E package (above) plus Ground Detection Alarm (Refer to the LCD C.A.P. System data sheet for complete details).

- **204** C.A.P.system (Meets NFPA 110)
Includes (1) set of form "C" contacts for AC Power Failure. Low DC Voltage, High DC Voltage, and Low DC Current.
- **03M** Low/High DC Voltage Alarm & Lights with (1) set of Form "C" contacts each for Low Voltage & High Voltage w/LED's

ABS/USCG (U.S. Coast Guard)

- **10B** U.S.C.G. Accessories, includes a drip shield, on/off switch & water tight connectors.
- **38G** ABS (American Bureau of Shipping) Type Approval with option 060, 16E or 16J.
- **38J** ABS & U.S.C.G. Accessories with option 060, 16E or 16J.

Internal Charge Dividers

(consult factory may increase case size)

- **100** To charge 2 batteries w/negative common.
- **10U** To charge 2 batteries w/positive common.
- **101** To charge 3 batteries w/negative common.
- **10V** To charge 3 batteries w/positive common.

Model Number Nomenclature

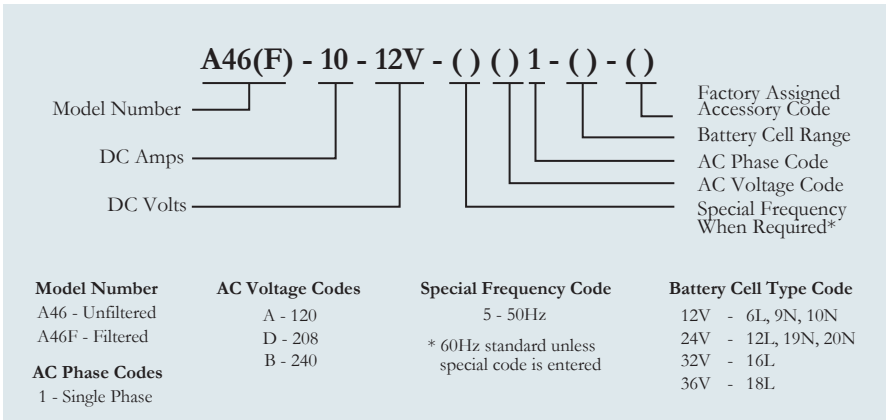

Environmental:

Operating Temperature:
0 to 50° C (32 to 122° F)

Storage Temperature:
-40 to 85° C (-40 to 185° F)

Relative Humidity:
0 to 95% non-condensing

- NEMA 1 enclosure ANSI 61 gray baked enamel paint



The Industry's Most Reliable Filtered Battery Charger / Power Supply



Standard



16 Series CAP
W/Breakers



46 Series CAP
W/Breakers



The La Marche model A12B Series Filtered Battery Chargers / Power Supplies are engineered for the demanding requirements of SwitchGear applications, Process Controls and Communications. The magnetic amplifier circuitry is designed to carry continuous and intermittent loads up to the maximum rated output. Its robust design and unmatched reliability has made this workhorse the standard in the industry and with its customizing features.

Refer to Digital C.A.P. System Data Sheet for complete details.

Standard Features

- Magnetic Amplifier Circuitry
- Separate Float and Equalize Potentiometers provide simple and precise DC Voltage calibration
- Float/Equalize Mode Switching
- Float and Equalize Lights
- Automatic AC Voltage Compensation
- +/- 0.5% DC Voltage Regulation
- Fused AC input and DC output protects Battery and Charger/Power Supply
- Analog DC Ammeter and DC Voltmeter
- Current Limiting Circuitry prevents overload and provides current control from 50 to 120% of rated output (factory set at 115%)
- Output Filtered (With or Without a Battery) - 30mV RMS for Single Phase Models and 100mV RMS for Three Phase Models
- AC Power Failure Relay with Form "C" Contacts
- AC Surge Suppression (MOV)
- NEMA Type 1 Enclosure / IP20
- UL 1012 & C-UL Listed (UL 1481 Listing available)
- 10-year Limited Warranty



Specifications

ELECTRICAL

- **AC Input Voltages**
Single Phase 60Hz: 120, 208, 220, 240, 480 or 600
Single Phase 50Hz: 220/240, 380 or 415
Three Phase 60Hz: 208, 240, 480 or 600
Three Phase 50Hz: 220/240, 380 or 415
Voltage range: +/- 10% from nominal
Frequency range: +/- 5%
- **Power Protection**
AC Fuse, DC Fuse and Current Limit Protection
- **DC Output Amps and Voltages**
DC Amps: 3 to 400 amperes
DC Volts: 12, 24, 48, 130VDC (Others available such as 32, 36 & 260VDC)
- **Output Filtering (With or without a battery)**
30mV RMS for single phase models and
100mV RMS for three phase models
- **DC Voltage Regulation**
Plus or minus 0.5% of setting from no load to full load over the specified input voltage, frequency and ambient temperature ranges.

ENVIRONMENTAL

- **Operating Temperature**
0° to 50°C (32° to 122°F)
- **Storage Temperature**
-40° to 85°C (-40° to 185°F)
- **Relative Humidity**
0 to 95% (non-condensing)
- **MTBF**
Exceeds 250,000 Hours
- **Dimensions**
Overall dimensions and weights are listed on the last page of this Data Sheet. Case specifications are subject to change due to innovative product development and design. When space requirements are critical, please consult the factory.
- **Mounting**
Floor or wall units are available. Mounting flanges are supplied as integral part of cabinet back plate on wall mounted models.
- **Finish**
Pretreated with a seven stage iron phosphate wash, sealer and deionized rinse. Then coated with an environmentally safe and durable ANSI 61 gray Polyester TGIC Minitel powder finish.

AGENCY APPROVALS

- **UL Battery Charger**
File E 319318, Guide BBML
UL Std. No. 1012
- **C-UL Battery Charger**
CAN/CSA
Std. C22.2 No. 107-2
- **UL Fire Alarm System Power Supply**
File S2768, Guide UTRZ
UL Std. No. 1481
Must Specify Accessory Code 09A
24V output, 240V or less, 60Hz single phase input only.

Notes:
All models where appropriate will carry the U.L. and C-U.L. Battery Charger listing. When U.L. Fire Alarm System Power Supply Listings are required, you must specify this requirement at the time of order. Not all models can be U.L. approved. Accessories, type of charger and rating will determine U.L. approval. Consult our factory if U.L. approvals are required.

Optional Accessories

ALARM & CONTROL

- **16 Series** (Refer to Digital C.A.P. Systems Data Sheet for complete details)
LED C.A.P. Systems common features:
Selectable Display, Multi-Mode Equalize Timer
Equalize Light
AC Power Failure Relay w/ (2) sets Form "C"
Low DC Current Alarm w/ (2) sets Form "C"
Low DC Voltage 1 Alarm w/ (2)sets Form "C" & Adjustable Time Delay (0-255 sec) (Except Ground Detection Alarms).
Multi-Mode Equalize Timer with Light adjustable from 1-144 hrs with five selectable modes and various failure alarm & lights.
- **46 Series** (Refer to Digital C.A.P. Systems Data Sheet for complete details)
2 Line LCD C.A.P. Systems common features:
Selectable Display, Multi-Mode Equalize Timer
Equalize Light
Float Light
AC Power Failure Relay w/ (2) sets Form "C" (Except 46Q)
Low DC Current Alarm w/ (2) sets Form "C"
Low DC Voltage 1 Alarm w/ (2)sets Form "C" & Adjustable Time Delay (0-255 sec) (Except Ground Detection Alarms).
Multi-Mode Equalize Timer with Light adjustable from 1-144 hrs with five selectable modes and various failure alarm & lights.
Discrete Alarm LEDs (46A & 46B) Available
- **46A** Discrete Alarm LEDs (with Ground Detection)
For use with CAP systems 46J, 46U, 46Q, 46T
- **46B** Discrete Alarm LEDs (w/o Ground Detection)
For use with CAP systems 46E, 46P, 46G, 46L
- **03N** Low DC Current Alarm & Light w/ (1) set Form "C" contacts
- **04J** Electronic Equalize Timer Multi-Mode adjustable from 2-144hrs with five selectable modes; Standard, 7-day, 14-day, 30-day and Equalize after Low DC Voltage.
- **050** Ground Detection Switch 3-position with DC Voltmeter indication (130VDC models utilizes two switches)
- **051** Ground Detection Alarm with Reset Pushbutton and (1) set form "C" Positive and (1) set form "C" Negative contacts
- **052** Ground Detection Lights (Positive and Negative)
- **053** Ground Detection Switch & Lights (130VDC models utilizes two switches)
- **054** AC Power Failure Light
- **16C** Hi/Lo-2 Combination Alarm High/Low DC Voltage, Field Calibrations & Adjustments, Individual Lights and (2) Form "C" contacts for each alarm
- **10G** Forced Load Sharing (with same model number only)
- **103** Remote Sensing
- **20Q** Equalize Fan Control Relay

METERING & PROTECTION

- **011** AC Breaker Single Pole (120VAC only)
- **012** DC Breaker Single Pole
- **016** AC Breaker Two Pole

METERING & PROTECTION CONTINUED

- **017** DC Breaker Two Pole
- **01B** AC Breaker Three Pole (3-phase input only)
- **01M** DC Breaker two Pole High Interrupting - 22KAIC (up to 250VDC)
- **01C** AC Breaker two Pole High Interrupting - 65/35/18KAIC (240/480/600VAC)
- **01D** AC Breaker two Pole High Interrupting - 100/65/25KAIC (240/480/600VAC)
- **01F** AC Breaker three Pole High Interrupting - 65/35/18 KAIC (240/480/600VAC)
- **01G** AC Breaker three Pole High Interrupting - 100/65/25KAIC (240/480/600VAC)
- **06G** Zero Center Ammeter w/Battery & Load Terminals (under 250A units)
- **06L** AC Ammeter +/-2% accuracy (single phase)
- **06M** AC Voltmeter +/-2% accuracy (single phase)
- **14V** AC Voltmeter with switch (three phase)
- **14W** AC Ammeter with switch (three phase)
- **102** DC Blocking Diode
- **107** DC Surge Protectors (MOV's)
- **11L** Lightning Arrestor
- **217** Reverse polarity Protection & LED

MISCELLANEOUS

- **09A** UL1481 (24V output, 240V or less, 60Hz single phase)
- **092** Tropicalization (magnetics only) Single Phase
- **093** Tropicalization (magnetics only) Three Phase
- **10B** USCG (U.S. Coast Guard) Accessories
- **10L** Battery & Load Terminals (under 250A units)
- **11F** 30mV Filtering for 3-phase units
- **38G** ABS (American Bureau of Shipping) Modifications
- **38J** ABS (38G) & USGC (10B) Single Phase
- **38K** ABS (38G) & USGC (10B) Three Phase
- **11V** Temperature Compensation (Internal Probe)
- **11W** External Temperature Probe 22 ft
- **38D** Copper Ground Bus Bar
- **095** Heat Shrinkable Wire Markers with Point to Point Wiring Diagram
- **09W** Heat Shrinkable Wire Markers with Electrical Schematic
- **09L** Physical Parts Location Drawing
- **097** SIS Wire (#16 AWG and larger) Markers
- **080** Drip Shield (must order separately)
- --- Floor Stand (must order separately)
- --- Special NEMA (3R, 4, 4X and 12) and IP Rated Enclosures

COMMUNICATION PROTOCOLS (Offered only with 46 series C.A.P.)

- **21J** IEC 61850 Ethernet
- **21P** DNP 3.0 Communications RS232/RS485/Ethernet
- **21Q** MODBUS Communications RS232/RS485/Ethernet
- **21S** MODBUS RTU Serial Data Port
- **21X** SNMP

Notes: Discrete Alarms are not available in conjunction with Digital C.A.P. (Combined Accessory Package) systems. Typically, when ordering two or more discrete components, the Digital C.A.P. system listed above provides a more economical approach.
Case sizes may differ depending on optional accessories and/or 50Hz input. Please consult factory when dimensions are critical.

TABLE OF CONTENTS

Please consult factory for other available cell ranges if desired range not shown.

Must specify only one battery type and number of cells from range shown above.

	Model Number	DC Amps	DC Fuse Size (Amps) ⁽¹⁾	AC Input Phase	AC Input Current Draw @ 100% Load (Amps) ⁽²⁾										Std. Case Size ⁽⁴⁾	Shipping Weight (Approximate)	
					60Hz Units					50Hz Units						lbs	kgs
					A 120	D 208	L 220	B 240	C 480	ZD 600	B 240 / L 220	G 380	J 415				
12 volt systems (6L, 9 or 10NC)	A12B-3-12V	3	10	1	0.8	0.4	0.4	0.4	---	---	---	0.4 / 0.4	---	---	7	60	28
	A12B-6-12V	6	15	1	1.5	0.9	0.8	0.8	---	---	---	0.8 / 0.8	---	---	7	70	32
	A12B-10-12V	10	20	1	2.5	1.4	1.4	1.3	---	---	---	1.3 / 1.4	---	---	7	80	37
	A12B-15-12V	15	25	1	3.8	2.2	2.1	1.9	---	---	---	1.9 / 2.1	---	---	3	90	41
	A12B-20-12V	20	30	1	5	2.9	2.7	2.5	---	---	---	2.5 / 2.7	---	---	3	95	44
	A12B-30-12V	30	40	1	7.5	4.3	4.1	3.8	1.9*	1.6*	---	3.8 / 4.1	2.4*	2.2*	3	105	48
	A12B-40-12V	40	60	1	10	5.8	5.5	5	2.5*	2.1*	---	5 / 5.5	3.2*	2.9*	6	155	71
	A12B-50-12V	50	80	1	13	7.2	6.8	6.3	3.1*	2.6*	---	6.3 / 6.8	4.0*	3.6*	6	170	78
	A12B-60-12V	60	80	1	15	8.7	8.2	7.5	3.8*	3.1*	---	7.5 / 8.2	4.7*	4.3*	6	180	82
	A12B-75-12V	75	100	1	19	11	11	9.4	4.7*	3.9*	---	9.4 / 11	5.9*	5.4*	6	225	103
A12B-100-12V	100	150	1	25	14	14	13	6.3*	5.2*	---	13 / 14	7.9	7.2	8A	315	143	
	100	150	3	---	7.5	7.1	6.5	3.3*	2.7*	---	6.5 / 7.1	4.1*	3.8*	8A	325	148	
24 volt systems (12L, 18, 19 or 20NC)	A12B-3-24V	3	10	1	1.5	0.9	0.8	0.8	---	---	---	0.8 / 0.8	---	---	7	70	32
	A12B-6-24V	6	15	1	3	1.7	1.6	1.5	---	---	---	1.5 / 1.6	---	---	3	85	39
	A12B-10-24V	10	20	1	5	2.9	2.7	2.5	---	---	---	2.5 / 2.7	---	---	3	95	44
	A12B-15-24V	15	25	1	7.5	4.3	4.1	3.8	1.9*	1.6*	---	3.8 / 4.1	2.4*	2.2*	3	100	46
	A12B-20-24V	20	30	1	10	5.8	5.5	5	2.5*	2.1*	---	5 / 5.1	3.2*	2.9*	3	120	55
	A12B-25-24V	25	35	1	13	7.2	6.8	6.3	3.1*	2.6*	---	6.3 / 6.8	4.0*	3.6*	3	135	62
	A12B-30-24V	30	40	1	15	8.7	8.2	7.5	3.8*	3.1*	---	7.5 / 8.2	4.7*	4.3*	3	145	66
	A12B-35-24V	35	50	1	18	11	9.6	8.8	4.4*	3.7*	---	8.8 / 9.6	5.5*	5.1*	6	190	87
	A12B-40-24V	40	60	1	21	12	11	10	5*	3.2*	---	10 / 11	6.3*	5.8*	6	205	93
	A12B-50-24V	50	80	1	26	15	14	13	6.3*	5.2*	---	13 / 14	7.9	7.2	6	240	109
	A12B-60-24V	60	80	1	31	18	17	15	7.5	6.3*	---	15 / 17	9.5	8.7	6	265	121
	A12B-75-24V	75	100	1	38	22	21	19	9.4	7.8	---	19 / 21	12	11	70	400	182
	A12B-100-24V	100	150	1	51	29	28	26	13	11	---	26 / 28	16	15	70	450	205
		100	150	3	---	16	15	13	7	6	---	13 / 15	8.5	8	70	500	227
	A12B-125-24V	125	200	3	---	19	18	17	8.1	6.8*	---	17 / 18	11	9.4	70	525	239
A12B-150-24V	150	200	3	---	23	22	20	9.8	8.2	---	20 / 22	13	12	72	630	286	
A12B-200-24V	200	250	3	---	30	29	26	13	11	---	26 / 29	17	16	27	825	375	
A12B-250-24V	250	300	3	---	38	36	33	17	14	---	33 / 36	21	19	27	880	400	
A12B-300-24V	300	400	3	---	46	43	40	20	17	---	40 / 43	25	23	27	940	427	
A12B-400-24V	400	600	3	---	61	57	53	26	22	---	53 / 57	33	31	47	1350	613	
48 volt systems (24L, 36, 37 or 38NC)	A12B-3-48V	3	10	1	3	1.7	1.6	1.5	---	---	---	1.5 / 1.6	---	---	7	85	39
	A12B-6-48V	6	15	1	6	3.5	3.3	3	---	---	---	3 / 3.3	---	---	3	90	41
	A12B-10-48V	10	20	1	10	5.8	5.5	5	2.5*	2.1*	---	5 / 5.5	3.2*	2.9*	3	140	64
	A12B-15-48V	15	25	1	15	8.7	8.2	7.5	3.8*	3.1*	---	7.5 / 8.2	4.7*	4.3*	3	180	82
	A12B-20-48V	20	30	1	21	12	11	10	5*	4.2*	---	10 / 11	6.3*	5.8*	6	205	93
	A12B-25-48V	25	35	1	26	15	14	13	6.3*	5.2*	---	13 / 14	7.9	7.2	6	240	109
	A12B-30-48V	30	40	1	31	18	17	15	7.5	6.3*	---	15 / 17	9.5	8.7	6	265	121
	A12B-40-48V	40	60	1	41	24	22	21	10	8.4	---	21 / 22	13	12	6	275	125
	A12B-50-48V	50	80	1	51	29	28	26	13	11	---	26 / 28	16	15	8A	355	161
	A12B-60-48V	60	80	3	---	18	17	16	7.8	6.5*	---	16 / 17	9.9	9	8A	400	182
	A12B-75-48V	75	100	3	---	23	22	20	9.8	8.2	---	20 / 22	13	12	72	525	239
	A12B-100-48V	100	150	3	---	30	29	26	13	11	---	26 / 29	17	16	72	625	284
	A12B-125-48V	125	200	3	---	38	36	33	17	14	---	33 / 36	21	19	72	700	318
	A12B-150-48V	150	200	3	---	46	43	40	20	17	---	40 / 43	25	23	27	850	386
	A12B-175-48V	175	250	3	---	53	50	46	23	19	---	46 / 50	29	27	27	1000	454
A12B-200-48V	200	250	3	---	61	57	53	26	22	---	53 / 57	33	31	27	1150	522	
A12B-250-48V	250	300	3	---	76	71	66	33	28	---	66 / 71	42	38	47	1400	635	
A12B-300-48V	300	400	3	---	91	86	79	40	33	---	79 / 86	50	46	47	1700	772	
A12B-400-48V	400	600	3	---	121	114	105	53	44	---	105 / 114	66	61	47	1800	817	
130 volt systems (54 through 60L, 92 through 97NC)	A12B-3-130V	3	10	1	7.5	4.3	4.1	3.8	---	---	---	3.8 / 4.1	---	---	3	140	64
	A12B-6-130V	6	15	1	15	8.7	8.2	7.5	---	---	---	7.5 / 8.2	4.7*	---	3	140	64
	A12B-10-130V	10	20	1	26	15	14	13	6.3*	5.2*	---	13 / 14	7.9	7.2	6	225	103
	A12B-15-130V	15	25	1	38	22	21	19	9.4	7.8	---	19 / 21	12	11	6	250	114
	A12B-20-130V	20	30	1	51	29	28	26	13	11	---	26 / 28	16	15	6	270	123
		20	30	3	---	15	14	13	6.5	10	---	13 / 14	8.2	7.5	8A	360	164
	A12B-25-130V	25	35	1	63	37	35	32	16	14	---	32 / 35	20	19	8A	355	161
		25	35	3	---	19	18	16	8.1	13	---	16 / 18	10	9.4	8A	390	177
	A12B-30-130V	30	40	1	75	44	41	38	19	16	---	38 / 41	24	22	8A	390	177
		30	40	3	---	23	21	20	9.8	16	---	20 / 21	12	11	8A	430	196
	A12B-35-130V	35	50	1	88	51	48	44	22	19	---	44 / 48	28	26	72	505	230
		35	50	3	---	27	25	23	12	9.5	---	23 / 25	15	14	72	580	264
	A12B-40-130V	40	60	1	101	58	55	51	26	21	---	51 / 55	32	29	72	550	250
		40	60	3	---	30	29	26	13	11	---	26 / 29	17	16	72	625	284
	A12B-50-130V	50	80	3	---	38	36	33	17	14	---	33 / 36	21	19	72	645	293
	A12B-60-130V	60	80	3	---	46	43	40	20	17	---	40 / 43	25	23	27	865	393
	A12B-75-130V	75	100	3	---	57	54	49	25	21	---	49 / 54	31	29	27	930	422
	A12B-100-130V	100	150	3	---	76	71	66	33	28	---	66 / 71	42	38	27	1040	472
	A12B-125-130V	125	200	3	---	94	89	82	41	34	---	82 / 89	52	48	47	1500	681
	A12B-150-130V	150	200	3	---	113	107	98	49	41	---	98 / 107	62	57	47	1800	817
A12B-175-130V	175	250	3	---	132	125	114	57	48	---	114 / 125	72	66	47	1950	885	
A12B-200-130V	200	250	3	---	151	142	131	66	55	---	131 / 142	83	76	47	2100	953	
A12B-250-130V	250	300	3	---	188	178	163	82	68	---	163 / 178	103	95	47	2300	1044	
A12B-300-130V ⁽³⁾	300	400	3	---	226	214	196	98	82	---	196 / 214	124	113	47B	2400	1089	
A12B-400-130V ⁽³⁾	400	600	3	---	301	285	261	131	109	---	261 / 285	165	151	57	2550	1157	

⁽¹⁾ Optional DC Breaker when ordered in lieu of standard fuse(s) may slightly differ in ratings. AC Draws shown with asterisk * when equipped with AC Breaker, a series fuse is included.
⁽²⁾ AC Current Draws based @ 100% load and standard battery cells of 6L (12V), 12L (24V), 24L (48V) and 60L (130V). Maximum Current Draw is 120% of ratings shown. AC Current draws shown in Italics have high current draws for their specific input voltages - verification of input power requirement should be done prior to ordering. ⁽³⁾ Denotes units not UL Listed
⁽⁴⁾ Case sizes shown are for standard 60Hz units and may differ depending on optional accessories and/or 50Hz input. Please consult factory when dimensions are critical.

Case Specifications

Case No.	Overall Dimensions						Cable Entry (when facing unit)		
	Width		Depth		Height		AC input	DC output	Mounting
	in	mm	in	mm	in	mm			
3	15.375	391	11.000	279	23.750	603	RIGHT	LEFT	WALL / FLOOR
6	25.580	650	13.935	354	28.000	711	RIGHT / TOP / BOTTOM	LEFT / TOP / BOTTOM	WALL / FLOOR
7	14.250	362	10.625	270	19.875	505	RIGHT	LEFT	WALL / FLOOR
8A	27.200	691	15.250	387	32.500	826	RIGHT	LEFT	FLOOR
27	27.312	694	25.875	657	56.125	1426	TOP	TOP	FLOOR
47	38.000	965	39.375	1000	70.000	1778	TOP / BOTTOM	TOP / BOTTOM	FLOOR
47B	38.00	965	46.750	1188	71.125	1807	TOP / BOTTOM	TOP / BOTTOM	FLOOR
57	60.000	1524	36.000	914	80.000	2032	BOTTOM	BOTTOM	FLOOR
70	27.000	686	19.000	483	41.000	1041	RIGHT / BOTTOM	LEFT / BOTTOM	FLOOR
72	27.000	686	23.500	597	44.500	1130	RIGHT / BOTTOM	BOTTOM	FLOOR

Case sizes may differ depending on optional accessories and / or 50Hz input. Please consult factory when dimensions are critical. Dimensions shown above are overall footprint. Detailed dimensions drawings are available for mounting purposes.



46 Series (LCD)



16 Series (LED)

Refer to Digital C.A.P. System Data Sheet for complete details. Discrete alarm LEDs available.

Model Number Nomenclature

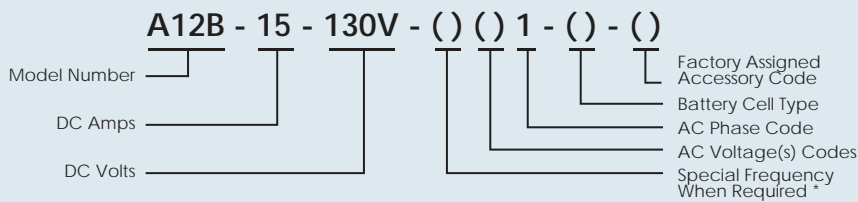

AC Phase Codes

- 1 - Single Phase
- 3 - Three Phase

AC Voltage Codes

- | | |
|-------------|--------------|
| 60Hz | 50Hz |
| A - 120 | BL - 240/220 |
| D - 208 | G - 380 |
| L - 220 | J - 415 |
| B - 240 | |
| C - 480 | |
| ZD - 600 | |

Special Frequency Code

- 5 = 50Hz
- * 60Hz standard unless special code is entered

Battery Cell Type

- L = Lead Acid
- LR = VRLA
- N = Nickel Cadmium

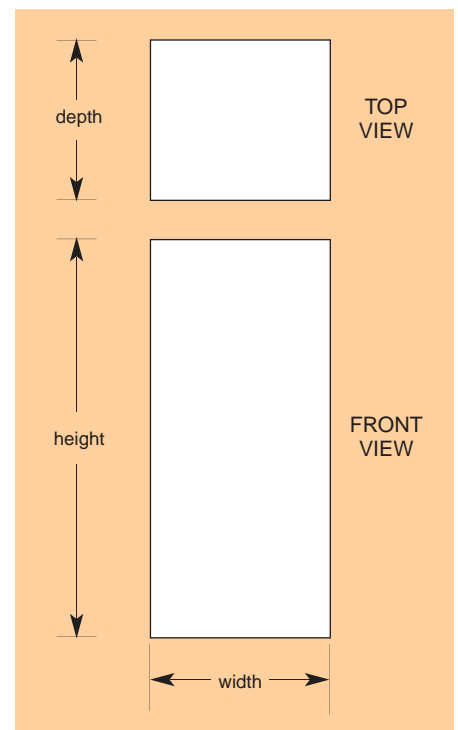

Ordering Information

When ordering, please specify:

- La Marche Model Number A12B
- Input Voltage, Frequency, Phase
- Number and Type of Battery Cells
- Amp Hour Capacity of Battery
- Intermittent DC Loads and Duration
- Continuous DC Load
- Allowable Recharge Time from Full Discharge (where applicable)
- Optional Accessories
- Verify AC Input Current Draw



Standard TPSD with LED Display



TPSD with LCD/VFD Display
(Option 550 / Option 551)



Standard Features

- LED Display
- Automatic DC Voltage Regulation
- Automatic AC Voltage Compensation
- Float/Equalize Mode Switching & LED Indicators (Adjustable FL / EQ voltage levels)
- Equalize Timer - adjustable from 1-144 hours with five selectable modes of operation (manual, automatic every 7, 14 or 30 days and equalize after sensing a low DC voltage)
- Positive and Negative Ground Detection
- AC & DC Surge Protection (MOV's)
- AC Input Circuit Breaker
- AC "ON" LED Indicator
- DC Output Circuit Breaker or Fuse
- Local & Remote Equalize Capability
- Local & Remote Output Voltage Sensing
- Output Load Current Sharing
- Internal Temperature Compensation
- Form "C" Relay Contacts with Adjustable Parameters:
 - Summary Alarm
 - AC Power Failure
 - Low DC Voltage
 - High DC Voltage
 - High DC Voltage Shutdown (HVSD)
 - Low Current
 - Positive and Negative Ground (not adjustable)
- Alarm Indicators:
 - Summary Alarm, Low DC Current, Low DC Voltage, High DC Voltage / HVSD, Ground Detection Fault
- U.L. 1012, C-UL Listed (for all 60Hz Units)
- 5-Year Limited Warranty

**TruPowerSource
Battery Charger / Power Supply**

The La Marche TPSD Battery Charger Series is designed to perform as a Power Supply / Battery Eliminator. This model incorporates Controlled Ferroresonant technology to provide the DC system with a dependable battery charger.

TPSD Battery Charger Series is engineered for the demanding requirements of Switchgear, Process Control, Oil and other DC power applications.

The design of the TPSD utilizes special magnetics that optimizes the performance of the charger. It's known for its High Efficiency, High Power Factor, Low Harmonic Distortion and inherent Current Limiting. The MTBF (Mean Time Between Failure) for this design is conservatively rated at 225,000 hours at 50 C°, assuring longevity and a higher return for your dollar.



LCD Display
(Option 550)



VFD Display
(Option 551)

TPSD with LCD/VFD Display (Option 550/551)

TPSD units equipped with an LCD or VFD display support the same features as standard units plus the following additions:

- 2 Line LCD or VFD Display
- Digital adjustments for the Charger Output (No Potentiometers), Alarms and Communication Settings
- User-Friendly Menu structure with push-button switches for ease of navigation
- Completely Configurable Alarm System
 - Alarm Thresholds
 - Delays
 - Contact Operations (Latching/Non-latching)
- Alarm Contacts testing capability to confirm functionality (Via front panel or remotely with optional communication card)
- Additional LED Indicators
 - AC Power Fail
 - Overload Alarm
 - End of Battery Discharge
 - High Voltage Shutdown
- Quick Start Instructions on the Front Panel with QR Code Link to the Charger's Instruction Manual



Specifications

ELECTRICAL

- **AC Input**
Voltage range: +/- 10% from nominal
Frequency range: +/- 5%
- **Single Phase models:**
A1: 120VAC/1/60Hz
ABD1: 120/240/208VAC/1/60Hz
BLD1: 240/220/208VAC/1/60Hz
C1: 480VAC/1/60Hz
5BL1: 240/220VAC/1/50Hz
- **Three Phase models:**
BD3: 240/208VAC/3/60Hz
C3: 480VAC/3/60Hz
5G3: 380VAC/3/50Hz
- **DC Output**
DC Amps: 6 to 200 amperes
DC Volts: 24, 48 & 130VDC
DC Output Voltage Range - a chart is provided on the last page of this data sheet.
- **Output Filtering (With or without a battery)**
30mV RMS for single phase models and 100mV RMS for three phase models.
- **DC Voltage Regulation Steady-State**
± 0.5% of setting from no load to full load over the specified input voltage, frequency and ambient temperature ranges.
- **Dynamic Response (On Battery)**
Voltage transient < ± 5% over a step change in the load from 20% to 100%. Recovery Time 200 ms.
- **Audible Noise**
Less than 65dBA at any point 5 feet from any vertical surface of the enclosure.
- **Load Sharing**
Load sharing terminal located inside of unit. When connected, identical La Marche Units are forced to share the load within ± 5% for individual unit outputs greater than 15% of the rated output.
- **Temperature Compensation**
5 step curve @ -0.001V/cell/°C as shown below (consult factory for other compensation rates).

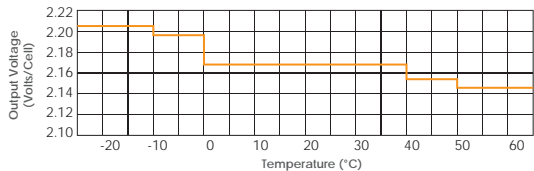

PROTECTION

- **Current Soft Start**
The output current will gradually increase after the charger is turned on, eliminating surges and overshoot.
- **Current Limit**
Electronic Current - Limiting Control Circuitry provides a digitally adjustable limit from 50 to 115% of the rated output current of the charger. Factory set at 115%.
- **DC Breaker & DC Fuse**
Standard units are equipped with a fuse or a 2-pole circuit breaker. For units equipped with a fuse, an optional breaker is available. Refer to the model chart on the next page for further details.
- **AC Breaker**
Single Phase Units:
A two-pole breaker opens both legs of the AC service to 208VAC and 240VAC. Breaker opens phase side of 120VAC service.
Three Phase Units:
A three-pole breaker opens all three legs of the AC service.

REMOTE MONITORING

- Form "C" Alarm Contacts
- With optional Communications Card:
 - Connect to SCADA System
 - Web Monitoring
 - Alarm / Notification E-mails

ENCLOSURES

- **Dimensions**
Overall dimensions and weights are subject to change due to innovative product development and design. When space requirements are critical, please consult the factory.
- **Mounting**
Our enclosures are very versatile. Some units can be wall, floor or rack mounted and others can be wall or floor mounted. See the Case Specifications Chart on the last page of this data sheet for further details.

ENCLOSURES

- **Finish**
Pretreated with a seven stage iron phosphate wash, sealer and deionized rinse. Then coated with an environmentally safe and durable ANSI 61 gray Polyester TGIC Minitex powder finish.

ENVIRONMENTAL

- **Operating Temperature**
0 to 50°C
- **Storage Temperature**
-40 to 85°C
- **Humidity**
0 to 95% Relative Humidity (Non-Condensing)
- **Cooling**
Convection cooled

Optional Accessories

- 550 Digital Controller with LCD Display
- 551 Digital Controller with VFD Display
- 017 DC Breaker 2-Pole (Standard on some units) see chart on pg. 3 for further details.
- 01C 2-Pole High Interrupting Capacity AC Breaker 65KAIC 240 VAC. Only available for units with current draws above 8 amps.
- 01D 2-Pole High Interrupting Capacity AC Breaker 65KAIC 480 VAC. Only available for units with current draws above 8 amps.
- 01G 3-Pole High Interrupting Capacity AC Breaker 65KAIC 480 VAC. Only available for units with current draws above 8 amps.
- 05C DC Current Transducer
- 206 DC Voltage Transducer
- 102 Blocking Diode
- 11W External Temperature Probe 22ft
- 11Y External Temperature Probe 100ft
- 11L Lightning Arrestor
- 09C I.D. Tags - White text on black background
- 09V I.D. Tags - Black text on white background
- 09W Heat Shrink Wire Markers with Electrical Schematic
- 38G ABS Type Approval
- 07V 4C Case (Pending UL Listing)
- 537 OSHPD Certification Label (consult factory for Anchor Kits)
- 538 IBC Certification Label (consult factory for Anchor Kits)

Communication Protocols

- 21J IEC 61850
- 21P DNP 3.0 Communications RS232/RS485/Ethernet
- 21Q Modbus Communications RS232/RS485/Ethernet
- 21S Modbus RTU - Serial Data Port
- 21X SNMP



Standard LED Display

TABLE OF CONTENTS

TPSD Charger Chart

1-Phase																				
Model Number	DC Amps	DC Protection		60Hz									50Hz ⁽³⁾				Heat Loss ⁽⁴⁾ BTU's/ Hour	Case No.		
				AC Current Draw ⁽¹⁾ Recommended Feeder AC Supply Breaker						Shipping Weight		AC Current Draw ⁽¹⁾ Feeder AC Supply Breaker		Shipping Weight						
		DC Fuse	DC Breaker/ Rating	A1 120	ABD1 120/240/208	BLD1 240/220/208	Feeder** Breaker Size	Rating	C1 480V	Feeder** Breaker Size	Rating	lbs	kgs	5BL1 240/220	Feeder** Breaker Size	lbs			kgs	
24V ⁽²⁾ (12L or 20NC)	TPSD-6-24V	6	---	10 / 7.5KAIC	2	---	---	5	2KAIC	---	---	---	90	40.8	---	---	---	---	119	4B***
	TPSD-12-24V	12	---	15 / 7.5KAIC	4	---	---	10	2KAIC	---	---	---	90	40.8	---	---	---	---	238	4B***
	TPSD-20-24V	20	---	30 / 7.5KAIC	---	6.7 / 3.4 / 3.9	---	10 / 5 / 5	5KAIC	---	---	---	100	45.4	3.4 / 3.7	5 / 5	110	49.8	396	4
	TPSD-25-24V	25	---	40 / 7.5KAIC	---	8.4 / 4.2 / 4.9	---	15 / 10 / 10	5KAIC	---	---	---	125	56.7	4.2 / 4.6	10 / 10	138	62.6	495	4
	TPSD-30-24V	30	---	40 / 7.5KAIC	---	11 / 5 / 5.8	---	15 / 10 / 10	5KAIC	---	---	---	150	68.0	5.0 / 5.5	10 / 10	165	74.8	405	4
	TPSD-35-24V	35	---	50 / 7.5KAIC	---	12 / 5.9 / 6.8	---	20 / 10 / 10	5KAIC	---	---	---	154	69.9	5.9 / 6.4	10 / 10	170	77.1	472	4
	TPSD-50-24V	50	---	70 / 7.5KAIC	---	17 / 8.4 / 9.7	---	30 / 15 / 15	5KAIC	---	---	---	175	79.4	8.4 / 9.2	15 / 15	193	87.5	674	4
	TPSD-75-24V	75	---	100 / 7.5KAIC	---	26 / 13 / 15	---	40 / 20 / 20	5KAIC	6.3	10	5KAIC	211	95.7	13 / 14	20 / 20	233	105.7	1011	4
TPSD-100-24V	100	130	Optional*	---	34 / 17 / 20	---	40 / 20 / 20	5KAIC	8.4	15	5KAIC	225	102.1	17 / 19	25 / 25	248	112.5	1347	9	
48V ⁽²⁾ (24L or 37NC)	TPSD-6-48V	6	---	10 / 7.5KAIC	4	---	---	10	2KAIC	---	---	---	90	40.8	---	---	---	---	191	4B***
	TPSD-12-48V	12	---	15 / 7.5KAIC	8.1	---	---	15	2KAIC	---	---	---	110	49.9	---	---	---	---	382	4B***
	TPSD-20-48V	20	---	30 / 7.5KAIC	---	14 / 6.7 / 7.8	---	20 / 10 / 10	5KAIC	---	---	---	150	68.0	6.7 / 7.3	10 / 10	165	74.8	637	4
	TPSD-25-48V	25	---	40 / 7.5KAIC	---	17 / 8.4 / 9.7	---	30 / 15 / 15	5KAIC	---	---	---	150	68.0	8.4 / 9.2	15 / 15	165	74.8	796	4
	TPSD-30-48V	30	---	40 / 7.5KAIC	---	21 / 11 / 12	---	30 / 15 / 15	5KAIC	---	---	---	155	70.3	11 / 11	15 / 15	171	77.6	601	4
	TPSD-35-48V	35	---	50 / 7.5KAIC	---	24 / 12 / 14	---	40 / 20 / 20	5KAIC	5.9	10	5KAIC	180	81.7	12 / 13	20 / 20	198	89.8	702	4
	TPSD-50-48V	50	---	70 / 7.5KAIC	---	34 / 17 / 20	---	40 / 20 / 20	5KAIC	8.4	15	5KAIC	205	93.0	17 / 19	25 / 25	225	102.1	1002	4
	TPSD-75-48V	75	---	100 / 7.5KAIC	---	51 / 26 / 30	---	70 / 35 / 35	5KAIC	13	20	5KAIC	295	133.8	26 / 28	40 / 40	325	147.4	1503	9
TPSD-100-48V	100	130	Optional*	---	---	34 / 37 / 39	50 / 50 / 50	5KAIC	17	25	5KAIC	321	145.6	34 / 37	50 / 50	354	160.6	2004	9	
130V ⁽²⁾ (58L or 60L 92NC or 96NC)	TPSD-6-130V	6	---	10 / 5KAIC	---	11 / 5 / 5.8	---	20 / 10 / 10	5KAIC	---	---	---	140	63.5	5.0 / 5.5	10 / 10	154	69.9	478	4
	TPSD-12-130V	12	---	15 / 10KAIC	---	21 / 11 / 12	---	30 / 15 / 15	5KAIC	---	---	---	175	79.4	11 / 11	15 / 15	193	87.5	955	4
	TPSD-20-130V	20	---	30 / 10KAIC	---	34 / 17 / 20	---	50 / 25 / 25	5KAIC	8.4	15	5KAIC	225	102.1	17 / 19	25 / 25	233	105.7	1591	4
	TPSD-25-130V	25	---	40 / 10KAIC	---	42 / 21 / 25	---	60 / 30 / 30	5KAIC	11	15	5KAIC	250	113.4	21 / 23	30 / 30	275	124.7	1989	4
	TPSD-30-130V	30	---	40 / 10KAIC	---	51 / 26 / 30	---	60 / 30 / 30	5KAIC	13	15	5KAIC	319	144.7	26 / 28	40 / 40	352	159.7	1503	9
	TPSD-35-130V	35	---	50 / 10KAIC	---	59 / 30 / 34	---	80 / 40 / 40	5KAIC	15	20	5KAIC	372	168.7	30 / 33	45 / 45	410	186	1753	9
	TPSD-50-130V	50	---	70 / 10KAIC	---	---	42 / 46 / 49	60 / 60 / 70	5KAIC	21	25	5KAIC	532	241.3	42 / 46	60 / 60	586	265.8	2504	9

* Optional DC Breaker is rated at 10KAIC.

** Recommended Breaker Size

*** Also available in 4C case

3-Phase																				
Model Number	DC Amps	DC Protection		60Hz									50Hz ⁽³⁾				Heat Loss ⁽⁴⁾ BTU's/ Hour	Case No.		
				AC Current Draw ⁽¹⁾ Recommended Feeder AC Supply Breaker						Shipping Weight		AC Current Draw ⁽¹⁾ Feeder AC Supply Breaker		Shipping Weight						
		DC Fuse	DC Breaker/ Rating	BD3 240/208V	Feeder** Breaker Size	Rating	C3 480	Feeder** Breaker Size	Rating	lbs	kgs	5G3 380V	Feeder** Breaker Size	lbs	kgs					
24V ⁽²⁾ (12L or 20NC)	TPSD-75-24V	75	---	100 / 7.5KAIC	6.3 / 7.3	10 / 10	5KAIC	---	---	---	400	181.4	---	---	---	---	752	72		
	TPSD-100-24V	100	130	Optional*	8.5 / 9.8	15 / 15	5KAIC	---	---	---	475	215.5	---	---	---	---	1002	72		
	TPSD-150-24V	150	200	Optional*	13 / 15	20 / 20	5KAIC	6.3	15	5KAIC	530	240.4	---	---	---	---	1503	72		
	TPSD-200-24V	200	250	Optional*	17 / 20	25 / 25	5KAIC	8.5	15	5KAIC	600	272.2	---	---	---	---	2004	72		
48V ⁽²⁾ (24L or 37NC)	TPSD-50-48V	50	---	70 / 7.5KAIC	8.5 / 9.8	15 / 15	5KAIC	---	---	---	400	181.4	---	---	---	---	1002	72		
	TPSD-75-48V	75	---	100 / 7.5KAIC	13 / 15	25 / 25	5KAIC	6.3	10	5KAIC	575	260.8	---	---	---	---	1503	72		
	TPSD-100-48V	100	130	Optional*	17 / 20	30 / 30	5KAIC	8.5	15	5KAIC	600	272.2	---	---	---	---	2004	72		
	TPSD-150-48V	150	200	Optional*	26 / 30	40 / 40	5KAIC	13	20	5KAIC	700	317.5	---	---	---	---	3005	72		
TPSD-200-48V	200	250	Optional*	34 / 40	60 / 60	5KAIC	17	25	5KAIC	755	342.5	---	---	---	---	4007	72			
130V ⁽²⁾ (58L or 60L 92NC or 96NC)	TPSD-25-130V	25	---	40 / 10KAIC	11 / 13	20 / 20	5KAIC	---	---	---	420	190.5	---	---	---	---	1252	72		
	TPSD-30-130V	30	---	40 / 10KAIC	13 / 15	20 / 20	5KAIC	6.3	10	5KAIC	490	222.3	---	---	---	---	1503	72		
	TPSD-35-130V	35	---	50 / 10KAIC	15 / 18	25 / 25	5KAIC	7.4	10	5KAIC	550	249.5	---	---	---	---	1753	72		
	TPSD-50-130V	50	---	70 / 10KAIC	22 / 25	35 / 35	5KAIC	11	20	5KAIC	600	272.2	---	---	---	---	2504	72		
	TPSD-75-130V	75	100	Optional*	32 / 37	50 / 50	5KAIC	16	25	5KAIC	660	299.4	20	30	727	329.8	3756	72		
	TPSD-100-130V	100	130	Optional*	43 / 49	70 / 70	5KAIC	22	30	5KAIC	800	362.9	27	35	882	400.1	5008	72		
	TPSD-125-130V ⁽³⁾	125	200	Optional*	53 ⁽³⁾ / 61 ⁽³⁾	80 / 80	5KAIC	27 ⁽³⁾	40	5KAIC	850	385.6	---	---	---	---	6260	44		
TPSD-150-130V ⁽³⁾	150	200	Optional*	64 ⁽³⁾ / 74 ⁽³⁾	100 / 100	5KAIC	32 ⁽³⁾	45	5KAIC	900	408.2	---	---	---	---	7512	44			

* Optional DC Breaker is rated at 10KAIC.

** Recommended Breaker Size

⁽¹⁾ AC Current Draws based @ 100% load and standard battery cells of 12L (24V), 24L (48V) and 60L (130V). Maximum Current Draw is 115% of ratings shown.

⁽²⁾ Must specify only one battery type and number of cells from range shown above. Please consult factory for other available cell ranges if desired range not shown.

⁽³⁾ Not UL Listed

⁽⁴⁾ BTU's are based on 12L (24V), 24L (48V) and 60L (130V). Heat loss is stated for nominal float voltage, 100% output current and nominal AC line.

TABLE OF CONTENTS

Case Specifications

Case No.	Overall Dimensions					
	Width		Depth		Height	
	in	mm	in	mm	in	mm
4B*	19.000	483	15.000	381	12.250*	311*
4C*	15.000	381	11.000	280	24.000*	610*
4*	19.000	483	15.000	381	24.000*	610*
9*	23.000	584	15.000	381	36.000*	914*
72	27.000	686	23.500	597	44.500	1130
44	24.000	610	19.000	483	72.100	1831

Case No.	Cable Entry (when facing unit)		Mounting
	AC input	DC output	
4B*	RIGHT TOP / BOTTOM / SIDE	LEFT TOP / BOTTOM	19/23" RACK, WALL/ FLOOR
4C*	RIGHT TOP / BOTTOM	LEFT TOP / BOTTOM / SIDE	WALL/ FLOOR
4*	RIGHT TOP/ BOTTOM	LEFT TOP / BOTTOM / SIDE	19/23" RACK, WALL / FLOOR
9*	RIGHT TOP / BOTTOM / SIDE	TOP / BOTTOM	23" RACK, WALL / FLOOR
72	RIGHT / BOTTOM / SIDE	BOTTOM	FLOOR
44	TOP LEFT	TOP RIGHT	FLOOR

*Floor mounting brackets add 2" (51mm) to overall height. Case sizes may differ depending on optional accessories. Consult factory when dimensions are critical. Detailed dimensional drawings are available for mounting purposes.

Adjustable DC Output Voltage Range

	Battery Cell Type Code	Float		Equalize	
		Min	Max	Min	Max
24V	12L	25.44	27.60	27.00	28.80
	20N	27.80	29.00	30.00	32.00
48V	24L	50.88	55.20	54.00	57.60
	37N	51.43	53.65	55.50	59.20
130V	58L	122.96	133.40	130.50	139.20
	60L	127.20	138.00	135.00	144.00
	92N	127.88	133.40	138.00	147.20
	96N	133.44	139.20	144.00	153.60

Battery Charger Sizing Guidelines

- Required Battery Backup Time (Hours)
- DC Output Voltage
- Ampere Hour Capacity of Battery
- Allowable Recharge Time From Full Discharge (Hours), Where Applicable
- Continuous and Intermittent DC Loads and Duration (Amps)

Model Number Nomenclature

TPSD - 25 - 130V - () () () - () - ()

Model Number ———

DC Amps ———

DC Volts ———

Factory Assigned Accessory Code

Battery Cell Range

AC Phase Code

AC Voltage(s) Code(s)

Special Frequency When Required **

**Special Frequency Code	AC Voltage Codes	AC Phase Codes	Battery Cell Type Code
5 - 50Hz	A - 120	1 - Single Phase	12L 20N 12LR
60Hz standard unless special code is entered	C - 480	3 - Three Phase	24L 37N 24LR
	G - 380		58L 92N 58LR
	BD - 240/208		60L 96N 60LR
	BL - 240/220		
	ABD - 120/240/208		L = Lead Acid
	BLD - 240/220/208		N = Nickel Cadmium
			LR = VRLA

Ordering Information

When ordering, please specify:

- La Marche Model Number TPSD
- DC Amps
- DC Volts
- Special Frequency, When Required
- AC Voltage Code
- AC Phase Code
- Battery Cell Type Code
- Optional Accessories (Option Code)



Unit Shown: MSM-30-24V-U1



Marine High Frequency Battery Charger

The MSM Series is a Smart High Frequency Switch Mode charger specifically developed for Marine applications. MSM series incorporates Power Factor Correction (PFC) Circuitry with a wide input voltage range in order to accommodate many marine charging applications.

The MSM has an Integrated Battery Charge Divider / Isolator which provides connections for charging up to three independent batteries simultaneously with a three-stage charge cycle. MSM's filtered output is suitable to charge different types of batteries for Marine/Industrial applications. This series is equipped with an LCD display for ease of navigation through the configurations menu. The LCD also displays Input AC voltage, Output DC Voltage & Current, and Alarm Status. The front of the unit provides three status LED indicators for the overall status of the system.

The MSM charger is built in a robust, non-corrosive enclosure that addresses harsh Marine environments, meeting stringent safety and regulatory standards. MSM chargers can be used inside engine rooms as this series is ignition protected 33 CFR 183.410 compliant.

Standard Features

- Smart Microprocessor Controlled High Frequency Charging Technology
- Single Phase AC Input 102-264VAC, 45-65Hz
- Complete Isolation from AC to DC
- LCD Digital Voltmeter & Ammeter
- Current Limit Protection
- Filtered Output for VRLA (Gel-Cell & AGM) Batteries
- Battery Isolator (Charge Divider allows for charging up to three Batteries Simultaneously)
- Input & Output Fuses
- On/Off Switch with Disable Option
- AC Voltage Metering
- Conformal Coated Circuit Boards
- Internal or External Temp. Compensation w/Disable Option (24ft Probe Included)

- Audible Charger Failure Alarm with LED Indicator and Form "C" Dry Relay Contacts
- IP22/NEMA Type 2 (with dripshield)
- 33 CFR 183.410 - Ignition Protection
- Corrosion Resistant
- Meets ABS & USCG Requirements
- CE Certified
- 2-Year Warranty

Optional Accessories

- 11Y** External Temperature Probe 100 feet
- 57Y** Modbus (Ethernet) TCP/IP
- 551** VFD Display
- 545** Solar Input w/MPPT Controller
- 57B** 5 Isolated Output Terminals
- Alarm Box: Low/High Voltage and Ground Fault (ordered separately)



TABLE OF CONTENTS

Model Number	AC Input 100% (load)		DC Output		Case No.	Net weight*	
	Volts (Nominal)	Amps	Volts (Nominal)	Amps		lbs	kgs
MSM-10-12V-U1	120	1.5	12	10	201	5	2.3
	240	0.8					
MSM-20-12V-U1	120	3.1	12	20	201	5	2.3
	240	1.6					
MSM-30-12V-U1	120	4.6	12	30	203	11	5.0
	240	2.4					
MSM-40-12V-U1	120	6.0	12	40	203	11	5.0
	240	3.2					
MSM-60-12V-U1	120	9.2	12	60	205	18	8.2
	240	4.8					
MSM-80-12V-U1	120	12.0	12	80	205	18	8.2
	240	6.4					

Model Number	AC Input 100% (load)		DC Output		Case No.	Net Weight*	
	Volts (Nominal)	Amps	Volts (Nominal)	Amps		lbs	kgs
MSM-10-24V-U1	120	2.6	24	10	201	5	2.3
	240	1.4					
MSM-20-24V-U1	120	5.2	24	20	203	11	5.0
	240	2.7					
MSM-25-24V-U1	120	6.5	24	25	203	11	5.0
	240	3.1					
MSM-30-24V-U1	120	7.8	24	30	203	11	5.0
	240	3.8					
MSM-35-24V-U1	120	9.1	24	35	203	11	5.0
	240	4.4					
MSM-50-24V-U1	120	13	24	50	205	18	8.2
	240	6.3					
MSM-65-24V-U1	120	16.9	24	65	205	18	8.2
	240	8.2					

*Weight does not include shipping packaging

Charger Specifications

- **AC Input**
Wide AC Input Range 102 - 264VAC
Single Phase 45 - 65 Hz
- **DC Output**
10 - 80A / 12V
10 - 65A / 24V
- **Power Factor**
0.99
- **Load Regulation**
<±0.5%
- **Input Protection**
Fuse with Surge and Transient Protection
AC Over Voltage Protection
- **Output Protection**
Current Limit Protection
Fuse with Surge Protection
Reverse Current Polarity
Thermal Protection
Short Circuit Protection
- **LED Indicators**
Current Limit
AC ON
Charger Fail
Low Current
- **Alarm Contacts**
Charger Failure

- **LCD Digital Display**
AC Input Voltmeter
DC Output Voltmeter and Ammeter (1%)
- **Environmental**
Operating: -20° to 50°C (-4° to 122°F)
Storage: -40° to 85°C (-40° to 185°F)
Relative Humidity: 0 to 95% non condensing
- **Adjustable Voltage Range**
10.4 to 14.1 (12V)
20.8V to 28.2V (24V)
- **Mounting**
Wall mount
- **Cable Entry**
Bottom
- **Finish**
Powder coated aluminum enclosure (corrosion resistant)
- **Standards**
UL 1236, ABS & USCG Requirements
EN 60335-1 (Electrical Safety)
IEC 60335-2-29 (Electrical Safety)
IEC 60068-2-6 (Sinusoidal Vibration)
EN 55011 (Radiated EMI)
IEC 1000-4-2 (Electrostatic Discharge)
IEC 1000-4-4 (Electrical Fast Transient)
33 CFR 183.410 (Ignition Protection)

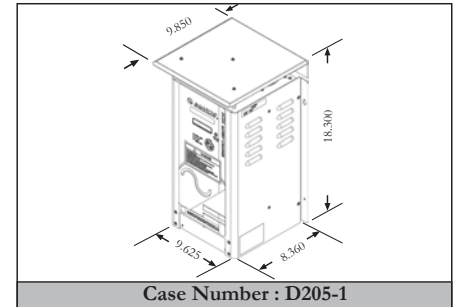
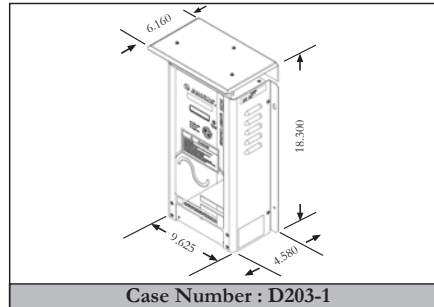
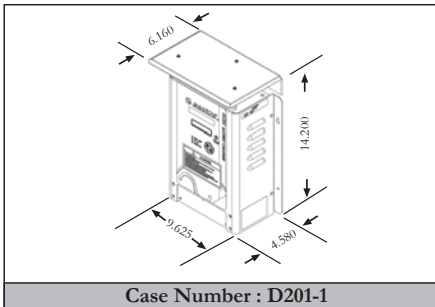

LCD Display



Model Number Nomenclature

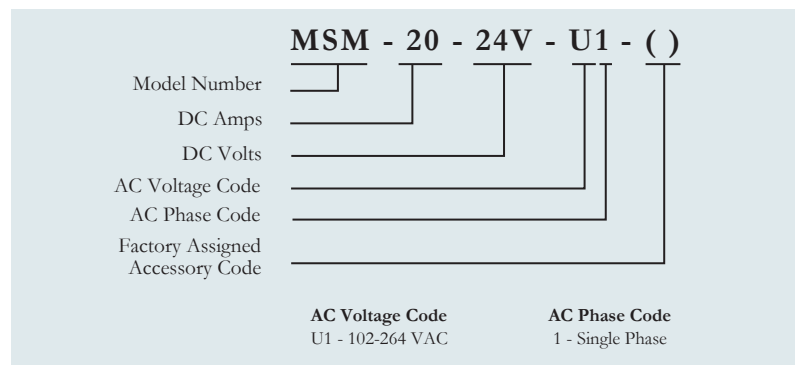



A-SERIES UPS SYSTEM

Up to 15 kVA



The La Marche A-Series UPS System is an Uninterruptible Power Supply system designed to power critical AC loads. Modular in concept, it utilizes separate rectifier and inverter components allowing for simplicity in sizing and growth for various requirements.

The Inverter section is compact and supplies a sine wave output. It provides reliability through transistor switching and a ferroresonant transformer which has inherent voltage regulation, output filtering and overload protection.

The Rectifier (Charger) section uses controlled ferroresonant technology, with separate adjustable voltage settings for float and equalize. It provides high efficiency, high power factor, short circuit protection, and an integral alarm package.

Rectifier Features

- Controlled Ferroresonant Technology
- 2 Line LCD or VFD Display
- Automatic DC Voltage Regulation
- Automatic AC Voltage Compensation
- Float/Equalize Mode Switching & LED Indicators (Digitally Adjustable FL / EQ voltage levels)
- Positive and Negative Ground Detection
- AC & DC Surge Protection (MOV's)
- AC Input Circuit Breaker
- AC "ON" LED Indicator
- DC Output Circuit Breaker or Fuse
- Local & Remote Equalize Capability
- Local & Remote Output Voltage Sensing
- Internal Temperature Compensation
- Form "C" Relay Contacts with Digitally Adjustable Parameters:
 - Summary Alarm
 - AC Power Failure
 - Low DC Voltage
 - High DC Voltage
 - High DC Voltage Shutdown (HVSD)
 - Low Current
 - Positive and Negative Ground (not adjustable)
- Alarm Indicators:
 - Summary Alarm, Low DC Current, Low DC Voltage, High DC Voltage / HVSD, Ground Detection Fault, AC Power Fail, Overload Alarm, End of Battery Discharge, HVSD
- Rectifier Design per U.L. 1012 and C-UL

Inverter Features

- Highly Reliable Ferroresonant Transformer
- Available DC Inputs 24V or 48V or 120V
- DC to AC Isolation
- Pure Sine Wave Output
- Adjustable DC Under/Over Voltage Shutdown
- Analog AC Ammeter & Voltmeter (2%)
- Overload/Current Limit
- Inverter On/Off Switch
- AC Circuit Breaker
- DC Circuit Breaker
- IGBT Power Block Technology
- Inverter Design per U.L. 1012 and C-UL

Static Switch Features

- 1ms Static Transfer Switch
- Inverter Prime or Standby
- Static Switch Alarm Package consisting of the following:
 - 2 Form "C" Contacts for Phase Lock, Utility Available, Inverter Available, Load on Preferred, Load on Alternate

5-Year Warranty



TABLE OF CONTENTS

UPS INPUT	UPS kVA Rating	(Up to 15) kVA - 1 Phase
	AC Input Voltage	3 Phase: 208Vac, 240Vac, 380Vac & 480Vac 1 Phase: 120Vac, 208Vac, 220Vac, 240Vac & 480Vac
	AC Input Range	-10% / +10%
	Input Frequency	50Hz or 60Hz ($\pm 5\%$)
UPS OUTPUT	AC Output Voltage	1 Phase: 120Vac, 208Vac, 220Vac & 240Vac
	Output voltage stability (0-100% load variation)	$\pm 3\%$ Steady Load $\pm 4\%$ From No Load to Full Load
	Output Frequency	50Hz or 60Hz $\pm 0.1\%$
	Total Harmonic Distortion	$\leq 5\%$ With 100% load
	Current Limit	Approximately 150%
	Load Power Factor	Unity to 0.8 lagging
	Output Crest Factor Admissible	2.8:1
DC LINK	DC Voltage	24Vdc 48Vdc 125Vdc
	DC Voltage Range	(21-30)Vdc (42-60)Vdc (105-150)Vdc
	Rectifier Output Voltage Stability	$\pm 0.5\%$
	Rectifier Output Voltage Ripple	30mV for Single Phase Unit 100mV for Three Phase Unit
	Battery Temperature Compensation	5 step curve @ -0.001V/cell
STATIC SWITCH	Transfer Time	1mS
	LED Indicators	Phase Lock Unity Available Inverter Available Load on Preferred Source Load on Alternate Source
MANUAL BYPASS	Switch Type	Rotary Switch
	Switching	Make Before Break
PROTECTION	Protection	Input Under Voltage, Input Over Voltage, Output Under Voltage, Output Over Voltage, Battery Over Charging, Input Inrush Current Protection by soft start as well as pre-charge circuit, Output Over Load, Battery Under Voltage, DC Over Voltage, Output Short Circuit
ENVIRONMENTAL	Ambient Temperature	0° to 50°C (32° to 122°F)
	Relative Humidity	0-95% non-condensing
	Operating Altitude	Up to 1000 meters without derating the output
MECHANICAL	Cooling	Convection Cooled
	External Protection	IP20 as standard (others available upon request)
	Dimensions	According to ratings and options

TABLE OF CONTENTS

MODEL NUMBER CHART

Model Number	VA	UPS Output / Bypass Input				AC Input				DC Bus		
		Phase	Volts (V)	Amps (A)	Freq. (Hz)	Phase	Volts (V)	Amps (A)	Freq. (Hz)	Voltage (Vdc)	Rectifier Capacity (A)	Inverter Input (A)
AUPS-2K-A1-ABD1-24V150A	2K	1PH	120	16.67	60	1PH	120/208/240	52/30/26	60	24	150	116
AUPS-2K-A1-C1-24V150A	2K	1PH	120	16.67	60	1PH	480	13	60	24	150	116
AUPS-2K-A1-BD3-24V150A	2K	1PH	120	16.67	60	3PH	208/240	15/13	60	24	150	116
AUPS-2K-A1-C3-24V150A	2K	1PH	120	16.67	60	3PH	480	6.5	60	24	150	116
AUPS-3K-A1-ABD1-24V200A	3K	1PH	120	25	60	1PH	120/208/240	68/40/34	60	24	200	174
AUPS-3K-A1-C1-24V200A	3K	1PH	120	25	60	1PH	480	17	60	24	200	174
AUPS-3K-A1-BD3-24V200A	3K	1PH	120	25	60	3PH	208/240	20/17	60	24	200	174
AUPS-3K-A1-C3-24V200A	3K	1PH	120	25	60	3PH	480	8.5	60	24	200	174
AUPS-3K-A1-ABD1-48V100A	3K	1PH	120	25	60	1PH	120/208/240	68/40/34	60	48	100	81
AUPS-3K-A1-BLD1-48V100A	3K	1PH	120	25	60	1PH	208/220/240	40/37/34	60	48	100	81
AUPS-3K-A1-C1-48V100A	3K	1PH	120	25	60	1PH	480	17	60	48	100	81
AUPS-3K-A1-BD3-48V100A	3K	1PH	120	25	60	3PH	208/240	20/17	60	48	100	81
AUPS-3K-A1-C3-48V100A	3K	1PH	120	25	60	3PH	480	8.5	60	48	100	81
AUPS-5K-A1-ABD1-48V150A	5K	1PH	120	42	60	1PH	120/208/240	52/30/26	60	48	150	132
AUPS-5K-A1-C1-48V150A	5K	1PH	120	42	60	1PH	480	13	60	48	150	132
AUPS-5K-A1-BD3-48V150A	5K	1PH	120	42	60	3PH	208/240	15/13	60	48	150	132
AUPS-5K-A1-C3-48V150A	5K	1PH	120	42	60	3PH	480	6.5	60	48	150	132
AUPS-10K-A1-BD3-48V300A	10K	1PH	120	84	60	3PH	208/240	60/52	60	48	300	278
AUPS-10K-A1-C3-48V300A	10K	1PH	120	84	60	3PH	480	26	60	48	300	278
AUPS-3K-A1-ABD1-125V35A	3K	1PH	120	25	60	1PH	120/208/240	59/34/30	60	125	35	32
AUPS-3K-A1-C1-125V35A	3K	1PH	120	25	60	1PH	480	15	60	125	35	32
AUPS-3K-A1-BD3-125V35A	3K	1PH	120	25	60	3PH	208/240	18/15	60	125	35	32
AUPS-3K-A1-C3-125V35A	3K	1PH	120	25	60	3PH	480	7.5	60	125	35	32
AUPS-5K-A1-ABD1-125V60A	5K	1PH	120	42	60	1PH	120/208/240	102/60/52	60	125	60	52
AUPS-5K-A1-C1-125V60A	5K	1PH	120	42	60	1PH	480	26	60	125	60	52
AUPS-5K-A1-BD3-125V75A	5K	1PH	120	42	60	3PH	208/240	37/32	60	125	75	52
AUPS-5K-A1-C3-125V75A	5K	1PH	120	42	60	3PH	480	16	60	125	75	52
AUPS-7.5K-A1-BLD1-125V100A	7.5K	1PH	120	62.5	60	1PH	208/220/240	98/92/84	60	125	100	79
AUPS-7.5K-A1-C1-125V100A	7.5K	1PH	120	62.5	60	1PH	480	42	60	125	100	79
AUPS-7.5K-A1-BD3-125V100A	7.5K	1PH	120	62.5	60	3PH	208/240	49/43	60	125	100	79
AUPS-7.5K-A1-C3-125V100A	7.5K	1PH	120	62.5	60	3PH	480	22	60	125	100	79
AUPS-10K-A1-BD3-125V125A	10K	1PH	120	84	60	3PH	208/240	61/53	60	125	125	105
AUPS-10K-A1-C3-125V125A	10K	1PH	120	84	60	3PH	480	27	60	125	125	105
AUPS-15K-A1-BD3-125V200A	15K	1PH	120	125	60	3PH	208/240	98/86	60	125	200	162
AUPS-15K-A1-C3-125V200A	15K	1PH	120	125	60	3PH	480	44	60	125	200	162

TABLE OF CONTENTS

Model	DC Voltage	UPS kVA Range
24Vdc	21Vdc - 30Vdc	Up to 3kVA
48Vdc	42Vdc - 60Vdc	1kVA - 10kVA
125Vdc	105Vdc - 150Vdc	1kVA - 15kVA

DIMENSIONS

	W	D	H	W	D	H
	inches			mm		
Up to 3kVA	28	25.5	60.0	711.2	647.7	1524.0
3 - 10kVA	48	25.5	72.0	1219.2	647.7	1828.8
10 - 15kVA	60	25.5	72.0	1524.0	647.7	1828.8

UPS BLOCK DIAGRAM

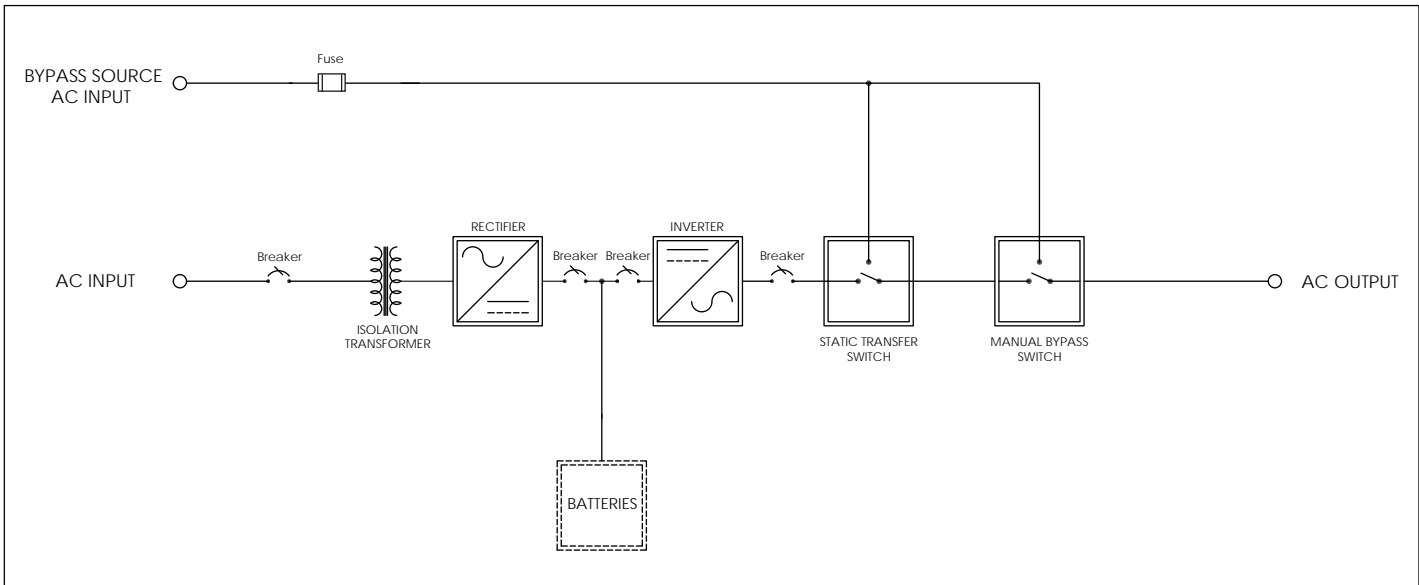



La MARCHÉ

ISO 9001:2000 CERTIFIED

TABLE OF CONTENTS

Model A32P / A32S Uninterruptible Power Supply (UPS) for Fire Alarm and Security Systems

Model A32P / A32S Uninterruptible Power Supply



Model shown A32P-1.5K-48VBC-A6-8-24

Standard Features

- Rectifier & Inverter U.L. 1481 Listed for Fire Alarm System
- High Quality Sine Wave
- Ferroresonant Design
- Automatic Electronic Transfer Switch
- Local & Remote Alarms
- LED Indicators & Switches
- Line Regulation & Load Regulation
- Environmental:
Operating Temperature: 0 to 50°C (32 to 122°F)
Storage Temperature: -20 to 60°C (-2 to 140°F)
Relative Humidity: 0 to 95% non-condensing
- NEMA 1 Enclosure ANSI 61 Gray Baked Enamel Paint
- 5 Year Limited Warranty

The La Marche model A32 series is an Uninterruptible Power Supply system designed to power critical AC loads. Modular in concept, it utilizes separate rectifier and inverter components allowing for simplicity in sizing and growth for various requirements.

All sub-system components (rectifiers and inverters) utilize a 48VDC bus and are listed under the UL 1481 Fire Protective Signaling Standard, making them ideal for central station and critical alarm system applications.

The La Marche model A31 Inverter is compact and supplies a sine wave output. It provides reliability through transistor switching and a ferroresonant transformer which has inherent voltage regulation, output filtering and overload protection.

The La Marche A36D Rectifier (Charger) uses controlled ferroresonant technology, with separate adjustable voltage settings for float and equalize. It provides high efficiency, high power factor, short circuit protection, and an integral alarm package.

U.L. 1481 Listed for Fire Alarm System

Available for primary or standby operation, the A32 series provides the highest form of reliable UPS protection for fire protective signaling applications.

La Marche Manufacturing Company
106 Bradrock Drive, Des Plaines, IL 60018-1967
Tel: 847-299-1188 Toll Free Fax: 1-888-232-9562
sales@lamarchemfg.com www.lamarchemfg.com

Made in U.S. A.

AC Output Voltage

120 Volt nominal, single phase.

Design Features

Regulation

Line : ±3 Over DC battery range.
Load : ±4% from no load to full load

Output Power Factor

Rated volts-amps continuous for unity to 0.8 lagging.

Frequency: 60 Hz

Frequency Regulation

±0.5% of the rated value and line synchronization- Quartz Crystal Control.

Wave Shape: Sine Wave

Total Harmonic Distortion (THD)

5% at nominal DC input and full load; less than 3% any single harmonic.

Approximate Efficiency: 85% to 90%

Noise: Less than 32 DBRN

*Refer to the A31 Data Sheet for further details.

AC Input Voltage

120/208/240 Volt, single phase, 60 Hz. (some models 120 Volt only)

Design Features

Steady-State

±0.5% from no load to full load over the specified input voltage, frequency, and ambient temperature ranges

Dynamic Response on Battery

Maximum voltage transient will not exceed ±5% of the initial steady-state voltage for a step change from 20% to 100% of the full rated load.

Current Walk In

Output current will gradually increase after the charger is turned on eliminating surges and overshoot.

Temperature Compensation

5 step @ 1mVpc/°C

Protection

Current Limit, AC Breaker and DC Breaker.

*Refer to the A36D Data Sheet for further details.

Protection
Inverter Input DC Breaker
Inverter Output AC Breaker
DC Undervoltage/Overvoltage Shutdown
Current Limit Protection
Reverse Polarity Indicator
Indicator/filter precharge circuit.

Alarm Status Panel
Equalize Indicator
Float Indicator
AC "ON" Indicator
Low Current Alarm Indicator
Low DC Voltage Alarm Indicator
High DC Voltage Alarm Indicator
Summary Rectifier Fail Alarm Indicator

Transfer Switches

1MS ELECTRONIC STATIC SWITCH

(provided on 1KVA and larger)

The La Marche Electronic Static Switch is an Automatic device that will transfer an AC load to and from the Prime Source to an Alternate Source, if the Prime Source fails in a rapid 1ms. The Static Transfer Switch is provided on the La Marche A31 DC to AC Inverters. Whether your Prime Source is established as your AC commercial line or the A31 Inverter, the Static Switch can be calibrated for either Source at the factory or at your site.

LED Indicators

- Phase lock
- Utility Available
- Inverter Available
- Load on preferred source
- Load on alternate source

15ms Electronic Static Switch

(provided on 500VA & 750VA)

An electronic load transfer switch is provided with approximately 15ms transfer time to switch the load from the inverter stage to the bypass source or from the bypass source to the inverter. Load voltage is sensed and power is transferred to the AC bypass source or the inverter. When the voltage is out of the specified value for longer than 15ms. This transfer point is adjustable by potentiometer. Retransfer is automatic after a time delay when both AC sources are available.

LED Indicators

- Bypass Available
- Inverter Available
- Load on alternate source

A32P - PRIME SYSTEMS

TABLE OF CONTENTS

UPS System Model Number	KVA	AC Output		Battery Charger U.L. 1481 Listed		Inverter U.L. 1481 Listed		Approx System Weight	No. of Battery Trays	*Backup Time Range in Hrs	Calculated Amp Hrs. Required		
		Volts	Amps	Model Number	AC Input		Model Number					DC Input Amps	
					Volts	Amps						N. L.	F. L.
"Prime" UPS System 24Hr Recharge													
A32P-500-48VBC-A6-2-24	0.5	120	4.17	A36D-15-48V-A1-24L	120	10.0	A31-500-48V-A6-24L	2.5	15.0	1	0.25 - 2	3.75 - 30	
A32P-500-48VBC-A6-8-24	0.5	120	4.17	A36D-20-48V-ABD1-24L	120/208/240	13.4/7.7/6.7	A31-500-48V-A6-24L	2.5	15.0	1	4 - 8	60 - 120	
A32P-500-48VBC-A6-24-24	0.5	120	4.17	A36D-30-48V-ABD1-24L	120/208/240	20.0/11.6/10.0	A31-500-48V-A6-24L	2.5	15.0	-	24	360	
A32P-750-48VBC-A6-4-24	0.75	120	6.25	A36D-25-48V-ABD1-24L	120/208/240	16.8/9.7/8.4	A31-750-48V-A6-24L	3.5	22.0	1	0.25 - 4	5.5 - 88	
A32P-750-48VBC-A6-8-24	0.75	120	6.25	A36D-30-48V-ABD1-24L	120/208/240	20.0/11.6/10.0	A31-750-48V-A6-24L	3.5	22.0	2	8	176	
A32P-750-48VBC-A6-24-24	0.75	120	6.25	A36D-50-48V-ABD1-24L	120/208/240	33.6/19.4/16.8	A31-750-48V-A6-24L	3.5	22.0	-	24	528	
A32P-1K-48VBC-A6-4-24	1	120	8.33	A36D-30-48V-ABD1-24L	120/208/240	20.0/11.6/10.0	A31-1K-48V-A6-24L	5.0	28.0	1	0.25 - 4	7 - 112	
A32P-1K-48VBC-A6-8-24	1	120	8.33	A36D-50-48V-ABD1-24L	120/208/240	33.6/19.4/16.8	A31-1K-48V-A6-24L	5.0	28.0	2	8	224	
A32P-1K-48VBC-A6-24-24	1	120	8.33	A36D-75-48V-ABD1-24L	120/208/240	50.4/29.1/25.2	A31-1K-48V-A6-24L	5.0	28.0	-	24	672	
A32P-1.5K-48VBC-A6-2-24	1.5	120	12.5	A36D-50-48V-ABD1-24L	120/208/240	33.6/19.4/16.8	A31-1.5K-48V-A6-24L	7.0	40.0	1	0.25 - 2	10 - 80	
A32P-1.5K-48VBC-A6-8-24	1.5	120	12.5	A36D-50-48V-ABD1-24L	120/208/240	33.6/19.4/16.8	A31-1.5K-48V-A6-24L	7.0	40.0	2	4 - 8	160 - 320	
A32P-1.5K-48VBC-A6-24-24	1.5	120	12.5	A36D-100-48V-ABD1-24L	120/208/240	67.2/38.8/33.6	A31-1.5K-48V-A6-24L	7.0	40.0	-	24	960	
A32P-2K-48VBC-A6-0.5-24	2	120	16.67	A36D-50-48V-ABD1-24L	120/208/240	33.6/19.4/16.8	A31-2K-48V-A6-24L	10.0	54.0	1	0.25 - 0.5	13.5 - 27	
A32P-2K-48VBC-A6-2-24	2	120	16.67	A36D-75-48V-ABD1-24L	120/208/240	50.4/29.1/25.2	A31-2K-48V-A6-24L	10.0	54.0	1	2	108	
A32P-2K-48VBC-A6-4-24	2	120	16.67	A36D-75-48V-ABD1-24L	120/208/240	50.4/29.1/25.2	A31-2K-48V-A6-24L	10.0	54.0	2	4	216	
A32P-2K-48VBC-A6-8-24	2	120	16.67	A36D-75-48V-ABD1-24L	120/208/240	50.4/29.1/25.2	A31-2K-48V-A6-24L	10.0	54.0	-	8	432	
A32P-2K-48VBC-A6-24-24	2	120	16.67	A36D-100-48V-ABD1-24L	120/208/240	67.2/38.8/33.6	A31-2K-48V-A6-24L	10.0	54.0	-	24	1296	
A32P-3K-48VBC-A6-0.5-24	3	120	25.0	A36D-100-48V-ABD1-24L	120/208/240	67.2/38.8/33.6	A31-3K-48V-A6-24L	13.0	81.0	1	0.25 - 0.5	20.25 - 40.5	
A32P-3K-48VBC-A6-2-24	3	120	25.0	A36D-100-48V-ABD1-24L	120/208/240	67.2/38.8/33.6	A31-3K-48V-A6-24L	13.0	81.0	2	2	162	
A32P-3K-48VBC-A6-8-24	3	120	25.0	A36D-100-48V-ABD1-24L	120/208/240	67.2/38.8/33.6	A31-3K-48V-A6-24L	13.0	81.0	-	4 - 8	324 - 648	
A32P-3K-48VBC-A6-24-24	3	120	25.0	A36D-100-48V-ABD1-24L ^(X2)	120/208/240	67.2/38.8/33.6	A31-3K-48V-A6-24L	13.0	81.0	-	24	1944	
A32P-4K-48VBC-A6-0.5-24	4	120	33.3	A36D-100-48V-ABD1-24L	120/208/240	67.2/38.8/33.6	A31-4K-48V-A6-24L	15.0	106.0	1	0.25 - 0.5	26.5 - 53	
A32P-4K-48VBC-A6-2-24	4	120	33.3	A36D-100-48V-ABD1-24L	120/208/240	67.2/38.8/33.6	A31-4K-48V-A6-24L	15.0	106.0	2	2	212	
A32P-4K-48VBC-A6-8-24	4	120	33.3	A36D-75-48V-ABD1-24L ^(X2)	120/208/240	50.4/29.1/25.2	A31-4K-48V-A6-24L	15.0	106.0	-	4 - 8	424 - 848	
A32P-4K-48VBC-A6-24-24	4	120	33.3	A36D-100-48V-ABD1-24L ^(X2)	120/208/240	67.2/38.8/33.6	A31-4K-48V-A6-24L	15.0	106.0	-	24	2544	
A32P-5K-48VBC-A6-0.5-24	5	120	41.67	A36D-75-48V-ABD1-24L ^(X2)	120/208/240	50.4/29.1/25.2	A31-5K-48V-A6-24L	16.0	132.0	1	0.25 - 0.5	33 - 66	
A32P-5K-48VBC-A6-4-24	5	120	41.67	A36D-75-48V-ABD1-24L ^(X2)	120/208/240	50.4/29.1/25.2	A31-5K-48V-A6-24L	16.0	132.0	-	2 - 4	264 - 528	
A32P-5K-48VBC-A6-8-24	5	120	41.67	A36D-100-48V-ABD1-24L ^(X2)	120/208/240	67.2/38.8/33.6	A31-5K-48V-A6-24L	16.0	132.0	-	8	1056	

Note: Backup time - range indicates the range of backup times that the systems can be used for. Example: A32P-500-48VBC-A6-8-24 can be used for applications of 4 Hrs - 8 Hrs.

(X2) = Two chargers per system

A32S - STANDBY SYSTEMS

TABLE OF CONTENTS

UPS System Model Number	KVA	AC Output		Battery Charger U.L. 1481 Listed		Inverter U.L. 1481 Listed		Approx System Weight	No. of Battery Trays	* Backup Time Range in Hours	Calculated Amp Hrs. Required		
		Volts	Amps	Model Number	AC Input		Model Number					DC Input Amps	
					Volts	Amps						N. L.	F. L.
"Standby" UPS System 24Hr Recharge													
A32S-500-48VBC-A6-8-24	0.5	120	4.17	A36D-10-48V-A1-24L	120	6.7	A31-500-48V-A6-24L	2.5	15.0	1	0.25 - 8	3.75 - 120	
A32S-500-48VBC-A6-24-24	0.5	120	4.17	A36D-20-48V-ABD1-24L	120/208/240	13.4/7.7/6.7	A31-500-48V-A6-24L	2.5	15.0	-	24	360	
A32S-750-48VBC-A6-4-24	0.75	120	6.25	A36D-10-48V-A1-24L	120	6.7	A31-750-48V-A6-24L	3.5	22.0	1	0.25 - 4	5.5 - 88	
A32S-750-48VBC-A6-8-24	0.75	120	6.25	A36D-15-48V-A1-24L	120	10	A31-750-48V-A6-24L	3.5	22.0	2	8	176	
A32S-750-48VBC-A6-24-24	0.75	120	6.25	A36D-30-48V-ABD1-24L	120/208/240	20.0/11.6/10.0	A31-750-48V-A6-24L	3.5	22.0	-	24	528	
A32S-1K-48VBC-A6-4-24	1	120	8.33	A36D-10-48V-A1-24L	120	6.7	A31-1K-48V-A6-24L	5.0	28.0	1	0.25 - 4	7 - 112	
A32S-1K-48VBC-A6-8-24	1	120	8.33	A36D-15-48V-A1-24L	120	10	A31-1K-48V-A6-24L	5.0	28.0	2	8	224	
A32S-1K-48VBC-A6-24-24	1	120	8.33	A36D-50-48V-ABD1-24L	120/208/240	33.6/19.4/16.8	A31-1K-48V-A6-24L	5.0	28.0	-	24	672	
A32S-1.5K-48VBC-A6-2-24	1.5	120	12.5	A36D-10-48V-A1-24L	120	6.7	A31-1.5K-48V-A6-24L	7.0	40.0	1	0.25 - 2	10 - 80	
A32S-1.5K-48VBC-A6-4-24	1.5	120	12.5	A36D-15-48V-A1-24L	120	10.0	A31-1.5K-48V-A6-24L	7.0	40.0	2	4	160	
A32S-1.5K-48VBC-A6-8-24	1.5	120	12.5	A36D-25-48V-ABD1-24L	120/208/240	16.8/9.7/8.4	A31-1.5K-48V-A6-24L	7.0	40.0	2	8	320	
A32S-1.5K-48VBC-A6-24-24	1.5	120	12.5	A36D-50-48V-ABD1-24L	120/208/240	33.6/19.4/16.8	A31-1.5K-48V-A6-24L	7.0	40.0	-	24	960	
A32S-2K-48VBC-A6-0.5-24	2	120	16.67	A36D-10-48V-A1-24L	120	6.7	A31-2K-48V-A6-24L	10.0	54.0	1	0.25 - 0.5	13.5 - 27	
A32S-2K-48VBC-A6-2-24	2	120	16.67	A36D-15-48V-A1-24L	120	10.0	A31-2K-48V-A6-24L	10.0	54.0	1	2	108	
A32S-2K-48VBC-A6-4-24	2	120	16.67	A36D-20-48V-ABD1-24L	120/208/240	13.4/7.7/6.7	A31-2K-48V-A6-24L	10.0	54.0	2	4	216	
A32S-2K-48VBC-A6-8-24	2	120	16.67	A36D-30-48V-ABD1-24L	120/208/240	20.0/11.6/10.0	A31-2K-48V-A6-24L	10.0	54.0	-	8	432	
A32S-2K-48VBC-A6-24-24	2	120	16.67	A36D-75-48V-ABD1-24L	120/208/240	50.4/29.1/25.2	A31-2K-48V-A6-24L	10.0	54.0	-	24	1296	
A32S-3K-48VBC-A6-0.5-24	3	120	25.0	A36D-15-48V-A1-24L	120	10.0	A31-3K-48V-A6-24L	13.0	81.0	1	0.25 - 0.5	20.25 - 40.5	
A32S-3K-48VBC-A6-2-24	3	120	25.0	A36D-20-48V-ABD1-24L	120/208/240	13.4/7.7/6.7	A31-3K-48V-A6-24L	13.0	81.0	2	2	162	
A32S-3K-48VBC-A6-4-24	3	120	25.0	A36D-30-48V-ABD1-24L	120/208/240	20.0/11.6/10.0	A31-3K-48V-A6-24L	13.0	81.0	-	4	324	
A32S-3K-48VBC-A6-8-24	3	120	25.0	A36D-50-48V-ABD1-24L	120/208/240	33.6/19.4/16.8	A31-3K-48V-A6-24L	13.0	81.0	-	8	648	
A32S-3K-48VBC-A6-24-24	3	120	25.0	A36D-100-48V-ABD1-24L	120/208/240	67.2/38.8/36.6	A31-3K-48V-A6-24L	13.0	81.0	-	24	1944	
A32S-4K-48VBC-A6-0.5-24	4	120	33.3	A36D-20-48V-ABD1-24L	120/208/240	13.4/7.7/6.7	A31-4K-48V-A6-24L	15.0	106.0	1	0.25 - 0.5	26.5 - 53	
A32S-4K-48VBC-A6-2-24	4	120	33.3	A36D-25-48V-ABD1-24L	120/208/240	16.8/9.7/8.4	A31-4K-48V-A6-24L	15.0	106.0	2	2	212	
A32S-4K-48VBC-A6-4-24	4	120	33.3	A36D-30-48V-ABD1-24L	120/208/240	20.0/11.6/10.0	A31-4K-48V-A6-24L	15.0	106.0	-	4	424	
A32S-4K-48VBC-A6-8-24	4	120	33.3	A36D-50-48V-ABD1-24L	120/208/240	33.6/19.4/16.8	A31-4K-48V-A6-24L	15.0	106.0	-	8	848	
A32S-4K-48VBC-A6-24-24	4	120	33.3	A36D-75-48V-ABD1-24L ^(X2)	120/208/240	50.4/29.1/25.2	A31-4K-48V-A6-24L	15.0	106.0	-	24	2544	
A32S-5K-48VBC-A6-0.5-24	5	120	41.67	A36D-20-48V-ABD1-24L	120/208/240	13.4/7.7/6.7	A31-5K-48V-A6-24L	16.0	132.0	1	0.25 - 0.5	33 - 66	
A32S-5K-48VBC-A6-2-24	5	120	41.67	A36D-30-48V-ABD1-24L	120/208/240	20.0/11.6/10.0	A31-5K-48V-A6-24L	16.0	132.0	-	2	264	
A32S-5K-48VBC-A6-4-24	5	120	41.67	A36D-50-48V-ABD1-24L	120/208/240	33.6/19.4/16.8	A31-5K-48V-A6-24L	16.0	132.0	-	4	528	
A32S-5K-48VBC-A6-8-24	5	120	41.67	A36D-75-48V-ABD1-24L	120/208/240	50.4/29.1/25.2	A31-5K-48V-A6-24L	16.0	132.0	-	8	1056	
A32S-5K-48VBC-A6-24-24	5	120	41.67	A36D-75-48V-ABD1-24L ^(X2)	120/208/240	50.4/29.1/25.2	A31-5K-48V-A6-24L	16.0	132.0	-	24	3168	

Note: Backup time - range indicates the range of backup times that the systems can be used for. Example: A32S-500-48VBC-A6-8-24 can be used for applications ranging from 15min - 8 Hrs.

(X2) = Two chargers per system

Model Number Nomenclature

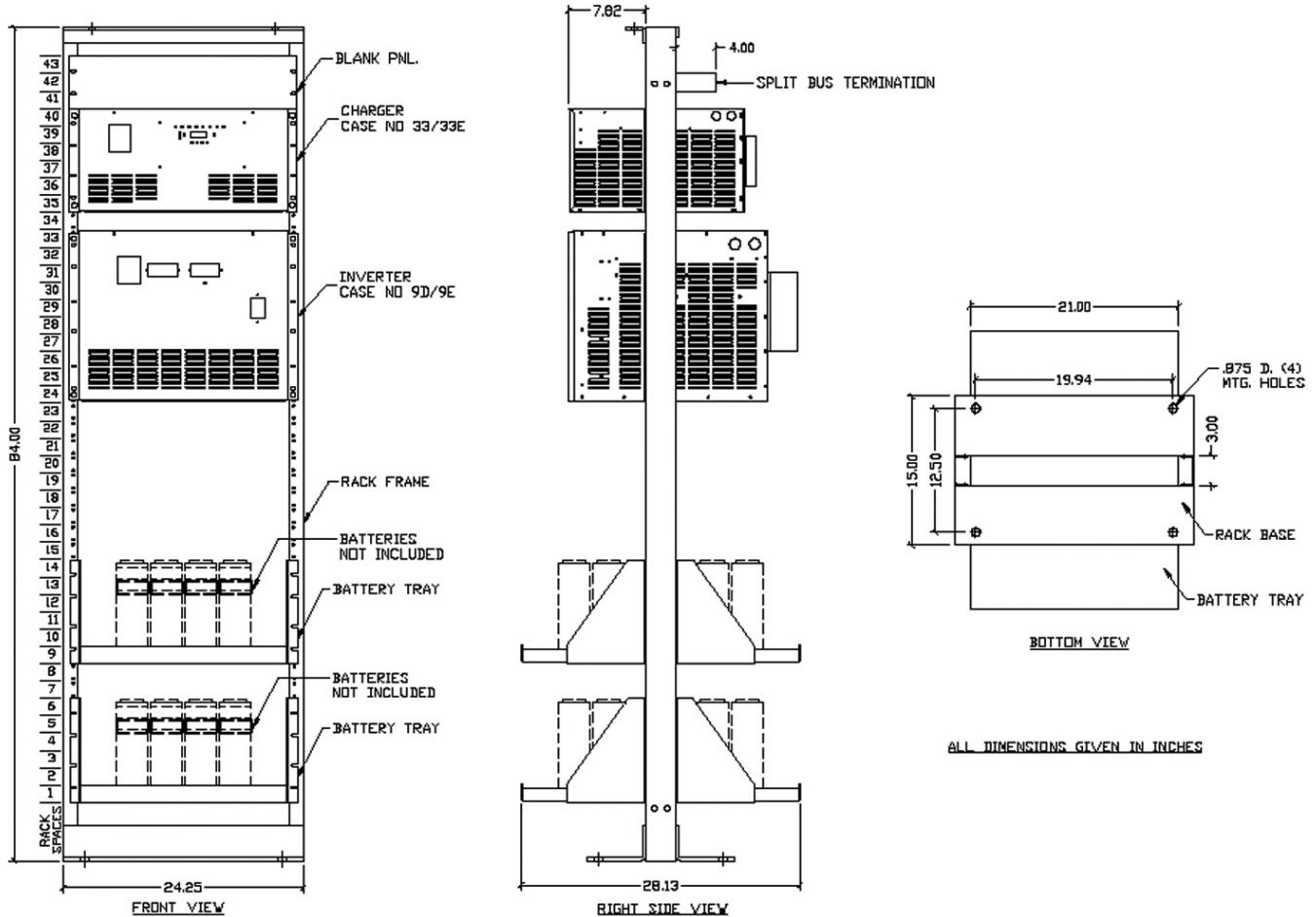
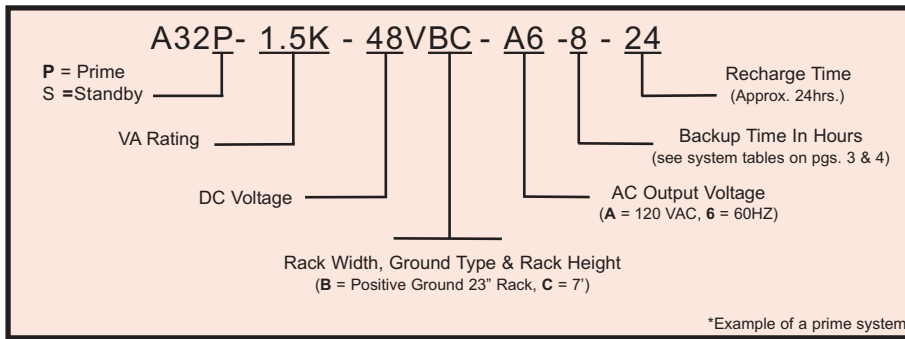

Standard System Components

- 1) 7 foot x 23 inch Open Relay Rack
- 2) Controlled Ferroresonant Charger (Positive Ground) UL 1481 approved.
- 3) Transistorized Ferroresonant Inverter - UL 1481 approved.
- 4) Split Bus Termination.

Environmental

- Operating Temperature**: 0 to 50°C
- Storage Temperature**: -20 to 60°C
- Relative Humidity**: 0 to 95% (Non-condensing)
- Cooling**: Convection

Notes

- A) System sized for 24 hour battery recharge.
- B) Static transfer switch reduces KVA output by 100VA
- C) Batteries are not included in the above systems. For battery requirements consult the factory.

Product Close-up

A31

- 1 AC Output Terminal
- 2 AC Output Breaker
- 3 AC Alt. Source Fuse
- 4 DC Input Terminal
- 5 DC Input Breaker
- 6 Static Switch
- 7 Control Board

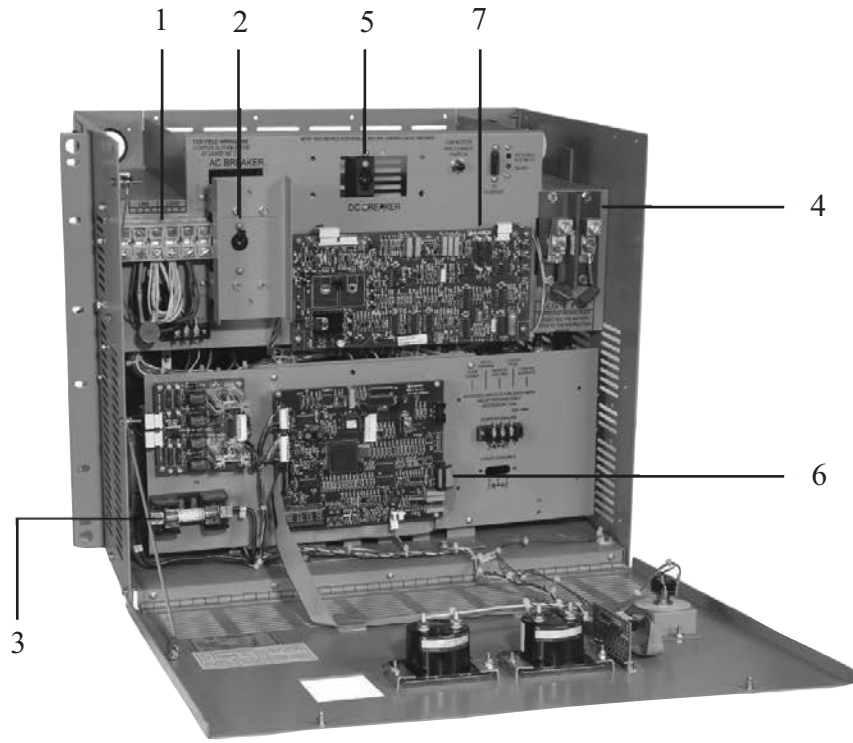

A36D

- 1 AC Breaker
- 2 AC Input Terminal Block
- 3 DC Output Terminal Block
- 4 DC Breaker
- 5 Alarm Terminal Strip
- 6 Remote Equalize, Sensing & Load Sharing Strip
- 7 AC Tap Jumper Terminal Strip

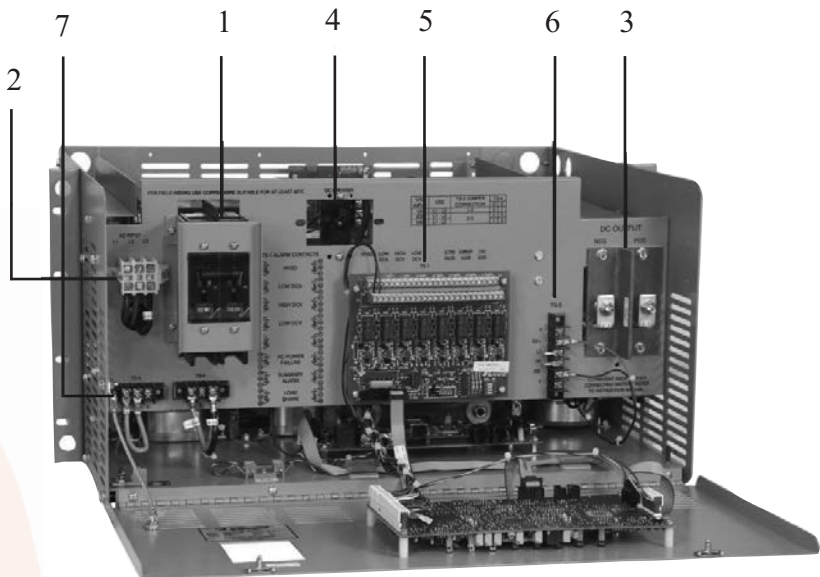



A39 UNIVERSAL SCR CHARGER



Model Shown A39-60-90V-BD1

UNIVERSAL SCR CHARGER

The La Marche model A39 charger is a microprocessor controlled SCR charger with adjustable output voltage, current limit and charge timer. This charger is designed to provide the battery charging flexibility needed for maintenance shops and other locations with various charging requirements.

This charger may be used as a constant current charger where the open circuit voltage can be adjusted or as a constant voltage charger with 1% regulation. The voltage and current limit adjusts from 5% to 100% of the rated value. This provides the flexibility to charge a wide range of Lead Acid or Ni-Cad battery cells. The charge timer range adjusts between 30 minutes to 99 hours in 30 minute increments.

A "Select" push-button changes the display function from AMPS, VOLTS, AMP HOURS RETURNED or TIME. The initial voltage setting is derived from the actual battery voltage when the battery is connected.

The model A39 will start upon connection to a battery and closure of the AC or optional DC breaker and will "Auto-Stop" when the charge cycle is terminated by action of a normal charge complete or opening the circuit breaker.

Standard Features

- Microprocessor Control
- Auto Start/Stop Circuitry
- Constant Current Mode Charging
- Wide Current, Voltage & Timer Ranges
- AC Breaker
- DC Breaker (Single Phase Units)
- Automatic Surge protection
- Digital Display
 - Voltage
 - Current
 - Timer Hours
 - AMP-Hours Returned
 - Voltage Setting
 - Current Setting
 - Timer Setting
- LED Lights for:
 - "ON" Charger
 - Charge Complete
 - Amps
 - Volts
 - Amp Hours
 - Elapsed Time
- Digital Adjustable
 - Output Voltage
 - Current Limit
 - Charger Timer
- Fault Mode Diagnostics
- Ten-foot Output Cable with Gray SB Type Connector

Optional

- DC Circuit Breaker (Three Phase Units)
- Safety Door Switch
- Mobile Caster Kit (Not Available for 480 VAC)
- Zero Volt Battery Start

Model	DC Output			Cells		AC Input	Case	Aprox. Weight (Lbs)
	Amps	Volts	Breaker	Lead	Nickel			
A39-60-30V-ABD1	60	30	Included	1 - 12	2 - 20	120/240/208 VAC - 1 PH.	6	175
A39-20-60V-ABD1	20	60	Included	3 - 24	6 - 40	120/240/208 VAC - 1 PH.	6	130
A39-40-60V-ABD1	40		Included			120/240/208 VAC - 1 PH.	6	190
A39-100-60V-BD3	100		Optional			240/208 VAC - 3 PH.	8A	325
A39-150-60V-BD3	150		Optional			240/208 VAC - 3 PH.	8A	350
A39-200-60V-BD3	200		Optional			240/208 VAC - 3 PH.	70	450
A39-100-60V-C3	100		Optional			480 VAC - 3 PH.	8A	325
A39-150-60V-C3	150		Optional			480 VAC - 3 PH.	8A	350
A39-200-60V-C3	200	Optional	480 VAC - 3 PH.	70	450			
A39-60-90V-BD1	60	90	Included	4 - 36	8 - 60	240/208 VAC - 1 PH.	6	300
A39-100-90V-BD3	100		Optional			240/208 VAC - 3 PH.	8A	350
A39-150-90V-BD3	150		Optional			240/208 VAC - 3 PH.	8A	565
A39-200-90V-BD3	200		Optional			240/208 VAC - 3 PH.	70	637
A39-100-90V-C3	100		Optional			480 VAC - 3 PH.	8A	350
A39-150-90V-C3	150		Optional			480 VAC - 3 PH.	8A	565
A39-200-90V-C3	200		Optional			480 VAC - 3 PH.	70	637
A39-30-150V-BD1	30	150	Included	6 - 60	12 - 106	240/208 VAC - 1 PH.	6	300
A39-50-150V-BD3	50		Optional			240/208 VAC - 3 PH.	8A	345
A39-100-150V-BD3	100		Optional			240/208 VAC - 3 PH.	8A	600
A39-150-150V-BD3	150		Optional			240/208 VAC - 3 PH.	27	640
A39-200-150V-BD3	200		Optional			240/208 VAC - 3 PH.	27	690
A39-100-150V-C3	100		Optional			480 VAC - 3 PH.	8A	345
A39-150-150V-C3	150		Optional			480 VAC - 3 PH.	27	600
A39-200-150V-C3	200		Optional			480 VAC - 3 PH.	27	690

Charger Specifications

Electrical

AC Input Voltages (60 Hz)

120/208/240 VAC single phase
240/208 VAC single or three phase
480 VAC three phase

DC Output Current

20 to 200 amps

DC Output Voltage Range

2-30 VDC
6-60 VDC
8-90 VDC
12-150 VDC

Operating Temperature

0° to 50° C

Regulation

1%

Finish

ANSI 61 baked enamel

Case Specifications

Case No.	Width		Depth		Height		Mounting
	in	mm	in	mm	in	mm	
6	25.5	650	13.9	354	28.0	711	Wall / Floor
8A	27.2	691	16.1	410	32.5	826	Floor
27	27.3	691	25.8	656	56.1	1425	Floor
70	27.0	686	19.0	483	41.0	1041	Floor

Model Number Nomenclature

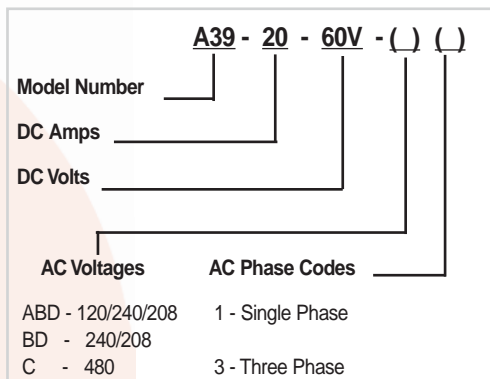

Ordering Information

When ordering, please specify:

- La Marche Model Number
- Optional Accessories



ISO 9001:2000 CERTIFIED

Specifications subject to change without notice

P25-DSA39-1
ECN 17462
04/07

106 Bradrock Drive, Des Plaines, IL 60018-1967
Tel: 847-299-1188 Toll Free Fax: 1-888-232-9562
sales@lamarchemfg.com www.lamarchemfg.com

La Marche A45E Battery Charger



DESIGN FEATURES

- Proven Mag Amp Technology
- Rugged Design, Built to Handle the Toughest Applications
- Automatic Current Limiting
- Automatic compensation for All AC Line Variations
- Simple, Solid State Design
- Easy to Operate
- Controlled Charging Cycle
- Available with Optional BOTE Ground Integrity System

Made In The USA

La Marche A45E Battery Charger — reliable charging capabilities combined with a superior monitoring system.

The La Marche A45E Battery Charger features an exclusive computer control system that automatically senses conditions the instant it is connected to a battery. It quickly determines the level of charge needed by the battery; reliably delivers the charge; and, maintains the charge at its optimum level for long-term battery performance.

The A45E monitoring system helps prevent both undercharging and overcharging. By delivering only the charge your battery needs, from start, through the gassing stage, to the finish charge, regardless of its charge level.

The charging curve of the A45E is easily adjusted to cover many battery designs and types. The exclusive La Marche Mag Amp technology provides automatic line compensation and adjustable DC output range through a specially designed input transformer and magnetic amplifier.

To minimize harmful temperature rise, the A45E is designed to return a maximum charge to the battery in the shortest possible time. Designed and built with La Marche quality inside and out, the A45E will service your batteries for years.

Call La Marche today for more details.

the powerful advantage™



La Marche A45E Battery Charger

Technical Data

Ordering Information

When Ordering Please Specify the Following

- La Marche model number A45E
- AC input voltage, phase and Hz
- Number and type of battery cells
- Ampere hour capacity of battery
- Standard recharging time is eight hours

Instant Decision Making

The A45E instantly analyzes DC current, DC voltage, AC voltage and power line frequency to provide a constant update on both battery and line conditions. The La Marche A45E also offers a wide spectrum of data and control function.

Push-button Data Selection

Utilizing an LED digital display, any of four operating parameters may be called up. Each push of the button advances the display one function from left to right. The operating parameters are updated automatically every 60 seconds. And, in the event of a power loss, all vital information is retained in the A45E's computer memory.

Output Amperes

The A45E displays actual output current within 1 amp.

Output Voltage

The A45E displays actual output voltage within .1 volts.

Ampere Hours Returned

The A45E displays accumulated amp hours returned to the battery from the start of the charge cycle.

Elapsed Time Display

The A45E can easily determine, at any time, the total accumulated charging time by selecting the "Elapsed Time" function. Elapsed time is shown in hours and minutes.

Status Lights

Important information can be retrieved utilizing the A45E's status lights. The status report provide the following functions:

- Charger On
- 80% Charge
- Charger Complete
- Equalize
- Unit Failure

Equalize Control

The A45E equalize charge cycle brings all the cells up to the same charging level when the control panel "Equalize" function is selected. An automatic 12-hour timer, in conjunction with electronic equalize circuitry, provides full charge protection.

Back-up Timer

The A45E is available with a 12-hour back-up timer. In the event of a system failure, the charger will protect your battery by shutting down. The charger "Failure" light will illuminate any time the back-up timer is activated. During an AC power line failure, the back-up timer retains memory.

Standard Features

10' DC leads with charging connector (SB, EC or YC)

Digital LED Display and Status Lights

- Output Amperes
- Output Voltage
- Ampere Hours Returned
- Elapsed Time
- Failure Diagnostic Code

Digital LED Status Lights

- Charger On
- 80% Charged
- Charge Complete
- Equalized Charge
- Unit Failure

Charge Completion On

- Voltage Rate of Change (DV/DT)
- Three Hours After 80% Charge
- Six Hours After 80% Charge in Equalized Mode
- Battery-operated Back-up Timer

Failure Diagnostics

The A45E will not only tell you that a failure has occurred by illuminating the "Failure" light, but it will also analyze the situation and instantly provide a numeric diagnostic code on the LED digital display. During a failure, the A45E automatically ceases charging operation.

Fault Lock-out

If the automatic charging mode is interrupted the A45E will shut down. Once the failure condition has been corrected, the manual "On/Off" switch is used to clear the "Failure" condition LED light, allowing the charger to restart.

Multiple Input — Voltage Capability

Simple transformer tap charges can be used to select the available input voltage.

Specifications

Standard Electrical AC Input Voltages

- 120/208/240, 50/60 Hz, single-phase
- 208/240/480, 50/60 Hz, single-phase or 3-phase
- 480/575, 50/60 Hz, 3-phase

DC Output Combinations

DC Amps — 30 to 400, depending on AH capacity (159-2,600 AH) of the battery and allowable charge time (eight hours typical).

DC volts

12 to 240 nominal, depending on the number and type of cells.

Mechanical

Exact dimensions and approximate weights are listed on individual A45E Price Sheets. Consult your La Marche representative or distributor for this information.

Control System

- Selectable 6-hour Equalize Charge Control
- Programmable Delayed Start
- Hold Time on AC Failure
- Resume Time on AC Line Return
- Fused AC Input and DC Output
- Internal Terminal Board for Easy Connection of AC Input and DC Output
- Back-up Timer (12-hour override)
- Failure Mode Diagnostics
- Fault Lock-out — Manual Reset on Failure Conditions
- Remote/Start/Stop Capability
- Verifies Battery Voltage and Polarity Before Starting
- Low Voltage Control Circuitry on All Models

Finish

Bonderized silicone baked enamel, medium blue.

Mounting

Wall or floor mounting available (depends on enclosure size).

Optional Accessories

- JIC Approved Enclosure — AC fused disconnect switch
- Fan-forced Cooling System
- 3-phase Input — where single-phase is indicated
- Special Paint
- Export Packaging
- Emergency Stop Button
- Two-circuit Sequence Control
- Three-circuit Sequencing Control

Warranty

La Marche equipment is warranted to be free from any defect in workmanship and material that may develop within a period of one year from date of purchase. In addition, La Marche warrants its magnetics and power diodes on a part replacement basis only for nine more years. See the Industrial division Manufacturer's Warranty for details.

the powerful advantage™



106 Bradrock Drive, Des Plaines, IL 60018 USA
Tel: (847) 299-1188, Fax: (847) 299-3061
<http://www.lamarche-power.com>



SCR Technology Mine Battery Charger



A75MD Single Circuit



A75MD2 Dual Circuit (Protective Roll Cage Optional)

The La Marche model A75MD mine battery charger product line utilizes microprocessor controlled SCR charging technology. The A75MD comes with a Vacuum Fluorescent Display (VFD) which is bright with clear contrast making them ideal for difficult lighting conditions.

This charger features automatic AC line voltage compensation, current limiting and controlled I-E-I charging cycle. The I-E-I charge cycle provides constant current start charge rate followed by constant voltage and completing with constant current finish rate. The constant current finish rate can be terminated either by DV/D'T, voltage limit or time to assure full charge.

The rugged A75MD is specially designed for the mining market to perform reliably under severe conditions such as moisture, corrosive atmosphere and rugged handling. The unit is convection cooled utilizing a 180°C class H insulation system and powder coat paint for durable finish.

A75MD2 is a dual circuit charger that allows for charging two batteries at the same time for multiple shift operation convenience.

Standard Features

- Available in Many AC Voltage Ratings
- Microprocessor Controlled Technology
- Controlled I-E-I Charging Cycle
- VFD Display
- Automatic Start / Stop Circuitry
- Programmable Entry of Battery AH Rating
- Smart DV/DT Termination
- Battery Equalize Switch
- Single Control Plate (Plug & Play)
- 12 Hour Override Timer
- Doors Safety Switches
- LED Indications:
 - Charge ON
 - Charge Cycle Status
 - Charger Mode
 - Fault LED
 - Data Logging Status
- Digital Display Indicates:
 - DC Volts
 - DC Amps
 - Amp Hours Returned
 - Elapsed Time on Charge
 - Error Codes
- Operating Temperature 0° to 50°C (32° to 122° F)
- Limited 5 year Warranty

Optional Accessories

- 05D** Advanced USB Data Logging
- 21M** Manual Start & Stop Push Buttons
- 21N** External 120 VAC Power Outlet Panel (3KVA)
- 093** Tropicalization (Magnetics Only)
- 184** Ground Integrity System (PA SPEC) (128VDC)
- 18J** Ground Integrity System (PA SPEC) (240VDC)
- 48A** IP54 Enclosure
- 48Q** Protective Roll Cage



TABLE OF CONTENTS

Model Number*	DC Output		Battery Amp- Hour Capacity 100% (8hr recharge @ High Selectable Rate)	AC Input Draw**		Case No.	Overall Dimensions W X D X H	Shipping Weight		
	Amp (Max)	Volts		480 VAC	575 VAC			lbs	kgs	
128 VDC 64 L	A75MD(2)-150-64L	153	128	850	58	48	26L	72.00" x 37.00" x 25.25" 1828.8 x 939.8 x 641.35mm	1,180	536.4
	A75MD(2)-180-64L	180	128	1000	65	54	26L	72.00" x 37.00" x 25.25" 1828.8 x 939.8 x 641.35mm	1,260	572
	A75MD(2)-210-64L	216	128	1200	70	58	26L	72.00" x 37.00" x 25.25" 1828.8 x 939.8 x 641.35mm	1,340	609.1
	A75MD-270-64L	270	128	1500	90	74	26L	72.00" x 37.00" x 25.25" 1828.8 x 939.8 x 641.35mm	1,545	702.3
	A75MD-360-64L	360	128	2000	115	95	Consult Factory			
240 VDC 120L	A75MD(2)-150-120L	153	240	850	96	80	26P	108.00" x 39.00" x 25.25" 2743.2 x 990.6 x 641.35mm	2,305	1,047.7
	A75MD(2)-180-120L	180	240	1000	111	93	26P	108.00" x 39.00" x 25.25" 2743.2 x 990.6 x 641.35mm	2,470	1,120.0
	A75MD-210-120L	216	240	1200	130	107	26P	108.00" x 39.00" x 25.25" 2743.2 x 990.6 x 641.35mm	2,610	1,186.4
	A75MD-270-120L	270	240	1500	168	130	26S	108.00" x 45.00" x 25.25" 2743.2 x 1143.0 x 641.35mm	2,980	1,354.5
320 VDC 160L	A75MD-150-160L	153	320	850	105	88	26G	42.25" x 67.25" x 28.00" 1075.2 x 1708.2 x 711.2mm	2,100	952.4
	A75MD-180-160L	180	320	1000	120	100	26G	42.25" x 67.25" x 28.00" 1075.2 x 1708.2 x 711.2mm	2,300	1,045.5

All above models designed for optimal performance at 60Hz. Consult factory for units designed specifically at 50Hz. Consult factory for availability of other DC cell range.

* Provided specifications are for single circuit A75MD chargers. For Dual Circuit chargers A75MD2 specifications, consult factory.

** AC Draws based @ 100% load.

Front Panel Display



Charger Output Ratings in DC Amps

Cell	Amp Rating	Selectable Output Amp (Amp-Hours)
64, 120 or 160	150	101 (560) - 153 (850)
64, 120 or 160	180	126(700) - 180(1000)
64 or 120	210	144 (800) - 216 (1200)
64 or 120	270	216 (1200) - 270 (1500)
64	360	270 (1500) - 360 (2000)

Model Number Nomenclature

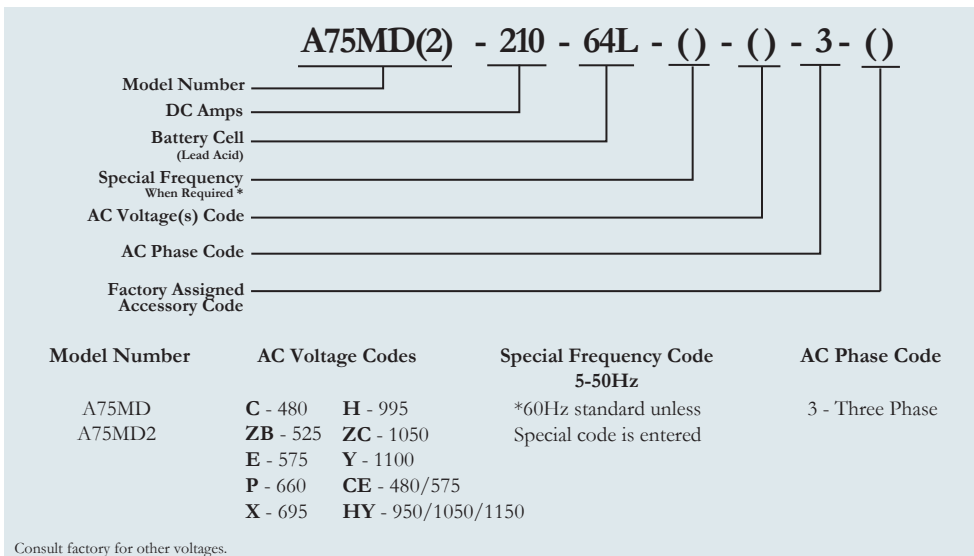

Consult factory for other voltages.

Ordering Information

When ordering, please specify:

- La Marche Model Number
- Input Voltage and Frequency
- Number and Type of Battery Cells
- Allowable Recharge Time
- Optional Accessories



Model shown: A75R-10-12V
A75R-20-12V



Model shown: A75R-30-24V
A75R-40-12V



Model shown: A75R-60-12V

SCR Railroad Applications

The La Marche A75R series battery chargers are specifically developed for the railroad market using proven SCR charging technology. Integrated features and functions are ideal for signaling, highway crossing, defect detectors and PTC's (positive train control). This filtered unit is designed and built to charge VRLA, Flooded Lead Acid and Nickel Cadmium batteries.

A75R's are packed with valued added features to make your DC system more reliable. Internal digital temperature Compensation circuitry prolongs battery life with optional external temperature sensor that can be mounted near the battery System. State of the art lightning protection circuit protects the unit against lightning surges. Charger failure contacts are Provided for remote annunciation. Remote shutdown capability allows the user to test DC System integrity or remotely shutdown the unit in emergency situations.

Mechanically designed to handle the most abusive environmental conditions. The A75R is built in NEMA 1 enclosure and equipped with AREMA style hardware for the input and output connections. This convection cooled unit has components conservatively chosen to achieve MTBF in excess of 100,000 hours.

Standard Features

- Microprocessor Controlled SCR Charging Technology
- Single Phase AC Input 120/240V, 50Hz/60Hz
- Automatic AC Input Voltage Compensation +/-10%
- Complete Isolation AC to DC
- DC Analog Ammeter and Digital Voltmeter
- Meets AREMA Specifications
- Meets ANSI C62-41 Standards for Surge Voltages
- 3-Year Warranty

Enhanced Features

- Superior Surge and Lightning Protection
- Automatic AC Input Voltage Selection for 10-40 Amp Models with No Tap Changes Required
- Integrated Charger Failure Alarm with Form "C" Contacts
- Selectable Low DC Current Alarm to detect when charger is not in service (output current is below .1A)
- Remote Shutdown Capability for Placing Charger Offline for Battery Testing Purposes
- DC Output Filtering for Higher Quality Battery Charging and Compatibility with Sensitive Loads Even with Battery Disconnected
- Adjustable Current Limit From 50% to 105% for Coordination with Limited Power Services
- Higher Temperature (Class H) Transformer Insulation and Conservative Component Selection for Long Life with Greater Safety Margins in Abusive Environments
- Selectable Temperature Compensation with Optional "Smart" Solid State External Probe



TABLE OF CONTENTS

Model Number	DC Output				AC Input Current Draw @ 100% (load)	Overall Dimensions W x D x H	Net Weight*	
	Amps	Volts (Nominal)	Battery Cells				lbs	kgs
			Lead Acid	Ni-Cad				
A75R-10-12V-AB1	10	12	5-8	8-12	5.8 amps / 120 VAC 2.9 amps / 240 VAC	12" x 10" x 9" 305 x 254 x 228mm	34	15.5
A75R-20-12V-AB1	20	12	5-8	8-12	6.5 amps / 120 VAC 3.3 amps / 240 VAC	12" x 10" x 9" 305 x 254 x 228mm	37	16.8
A75R-40-12V-AB1	40	12	5-8	8-12	13.8 amps / 120 VAC 7.0 amps / 240 VAC	14" x 12" x 12" 356 x 305 x 305mm	58	26.4
A75R-30-24V-AB1	30	24	10-16	16-24	16.5 amps / 120 VAC 8.3 amps / 240 VAC	14" x 12" x 12" 356 x 305 x 305mm	76	34.5
A75R-60-12V-A1	60	12	5-8	8-12	18.4 amps / 120 VAC	16.7" x 12" x 12" 427 x 305 x 305mm	80	36.3
A75R-60-12V-B1	60	12	5-8	8-12	9.3 amps / 240 VAC	16.7" x 12" x 12" 427 x 305 x 305mm	80	36.3

*Weight does not include shipping packaging

Charger Specifications

<ul style="list-style-type: none"> • AC Input Single Phase 120/240V ±10% 50Hz/60Hz ±5% • Line Regulation ±10% • Load Regulation <±0.5% • Input Protection Fuse with surge protection • Output Current Limit Factory set at 100%, adjustable from 50-105% • Output Protection DC breaker or fuse with surge protection • Meters DC Output Digital Voltmeter (1%) DC Output Analog Ammeter (2%) • LED Indicators Current Limit Temperature Compensation Disable AC On Nickel Cadmium Lead Acid Charger Fail • Environmental Operating: -40° to 70°C (Output derated above 50°C by 3% with the internal temperature compensation enabled) Storage: -40° to 85°C (-40° to 185°F) Relative Humidity: 0 to 95% non condensing 	<ul style="list-style-type: none"> • DC Output 12 Volts @ 10 Amps, 20 Amps, 40 Amps and 60 Amps Lead Acid: 5L, 6L, 7L and 8L Ni-Cad: 8NC, 9NC, 10NC, 11NC, 12NC 24 Volts @ 30 Amps Lead Acid: 10L, 12L, 14L and 16L Ni-Cad: 16NC, 18NC, 20NC, 22NC, 24NC • Adjustable Voltage Range (per cell) Lead-Acid Cells: 2.15 VDC to 2.35 VDC Ni-Cad: 1.39 VDC to 1.49 VDC • Mounting The enclosures can be wall or shelf mounted • Cable Entry Top • Finish Powder coat finish (RAL 7032) • Standards Meets AREMA specifications Meets ANSI C62-41 • Optional 11W External Temperature Probe 24 ft 11Y External Temperature Probe 100 ft
--	---

Model Number Nomenclature

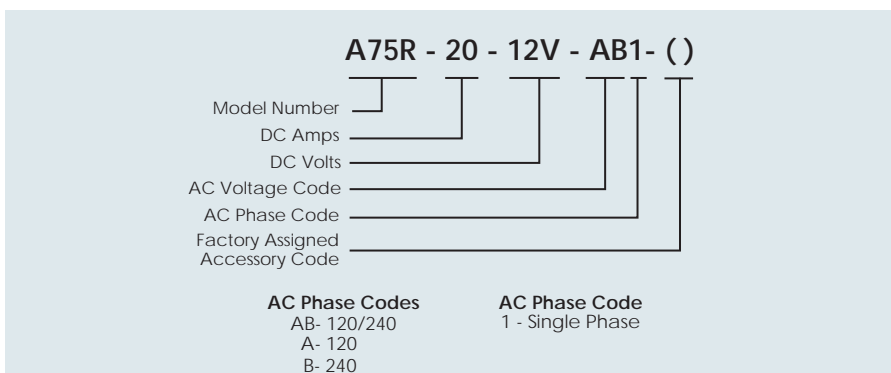

Ordering Information

When ordering, please specify:

- La Marche Model Number
- Input Voltage
- Number of Battery Cells
- Amp Hour Capacity of Battery
- Allowable Recharge Time from Full Discharge (where applicable)



Microprocessor Controlled SCR Battery Charger



Unit Shown: ESCR125-16-125V-ABD1

The La Marche ESCR125 Model is designed specifically to provide an economical and robust solution for Auxiliary DC Control Power Systems in Substations. This Smart Microprocessor controlled Battery Charger is designed with PWM controls to provide the highest reliability that is required for maintaining and recharging the batteries, along with supporting the continuous loads in the auxiliary DC system.

The La Marche ESCR125 is designed per NEMA PE5, C62.41A and UL safety requirements. This Filtered Battery Charger meets NEMA PE5 filtering requirements and has 0.5% DC voltage regulation from no load to full load (over the specified input voltage, frequency and ambient temperature ranges). Those features along with its Temperature Compensation capability make this model suitable for various types of batteries such as flooded lead acid, VRLA and NiCad.

ESCR125 is equipped with a two-line LCD which displays output voltage and current, along with an alarm status text description. Individual LED indicators provide local supervision, Form "C" Alarm Contacts and Communication Protocols are available for remote annunciation.

Standard Features

- Smart Microprocessor Controlled SCR Technology
- Filtered Battery Charger
- Automatic AC Voltage Compensation
- AC & DC Surge Protection (MOV)
- AC & DC Breaker
- Temperature Compensation
- Float/Equalize Mode Switch
- Digital Float and Equalize Adjustments
- Digital Current Limit Adjustment 50 to 110%
- ±0.5% DC Voltage Regulation
- Over Temperature Protection
- LCD Display
- Soft Start
- Meets NEMA PE5 and C62.41A
- UL/CUL 1012 (Pending)
- 2 Year Warranty

Optional Accessories

- 080** Drip Shield
- 09P** Conformal Coated Circuit Boards
- 11W** External Temperature Probe 24ft
- 11Y** External Temperature Probe 100ft
- 10R** AAR Hardware

TABLE OF CONTENTS

Model Number	DC Output			AC Input			Case No.	Overall Dimensions W x D x H	Shipping Weight	
	Volts (Nominal)	Amps	DC Breaker Rating	Volts (Nominal)	Current Draw	Feeder Breaker Size			lbs	kg
ESCR125-16-125V-ABD1	125	16	5kAIC	120/208/240	37/22/19	50/30/30	4E	15.3" x 11.0" x 23.7" 391 x 279 x 603mm	145	66
ESCR125-25-125V-ABD1	125	25	5kAIC	120/208/240	58/34/29	80/50/40	4E	19.0" x 15.0" x 24.0"* 483 x 381 x 610mm	159	72

*Floor mounting brackets add 2" (51mm) to overall height. Case sizes may differ depending on optional accessories. Consult factory when dimensions are critical. Detailed dimensional drawings are available for mounting purposes.

<p>AC INPUT</p> <ul style="list-style-type: none"> 120/208/240 VAC $\pm 10\%$, 50/60HZ, Single Phase <p>DC OUTPUT</p> <ul style="list-style-type: none"> 16A @ 125VDC 25A @ 125VDC <p>REGULATION</p> <ul style="list-style-type: none"> Line: $< \pm 0.5\%$ Load: $< \pm 0.5\%$ <p>OUTPUT FILTERING</p> <ul style="list-style-type: none"> Per NEMA PE5 Filtered Charger <p>PROTECTION</p> <ul style="list-style-type: none"> Input Breaker with Surge Protection Output Breaker with Surge Protection <p>BATTERY CELL SELECTION</p> <ul style="list-style-type: none"> 53L-62L 83NC-93NC <p>OUTPUT CURRENT LIMIT</p> <ul style="list-style-type: none"> Adjustable from 50 - 110% (Factory set at 105%) <p>ADJUSTABLE VOLTAGE RANGE</p> <ul style="list-style-type: none"> Float Voltage 2.12 - 2.35 volts/cell (Lead) 1.35 - 1.45 volts/cell (NiCad) Equalize Voltage 2.25 - 2.40 volts/cell (Lead) 1.45 - 1.6 volts/cell (NiCad) 	<p>METERING</p> <ul style="list-style-type: none"> LCD DC Output Digital Voltmeter and Ammeter (1%) <p>CONTROLS</p> <ul style="list-style-type: none"> Float and Equalize Button Switch from Float to Equalize Configure Button Output Settings Voltage and Cells Adjust Voltage for Float & Equalize Adjust Alarm Settings and Delay High Voltage Shutdown Enable/Disable Temperature Compensation Equalize Timer ~ Multi-Mode Equalize Timer and Light; adjustable from 1 - 145 hrs ~ Five selectable modes: Manual (Default Factory Setting), 7-day, 14-day, 30-day and Equalize after Low DC Voltage and/or AC Failure Battery Continuity Test Manual and Periodic Battery Test Lamp Test Tests LCD Display & LED's <p>ALARM CONTACTS</p> <ul style="list-style-type: none"> AC Failure Low DC Voltage High DC Voltage Charger Failure Alarm <p>Form "C" contact rated 2A @ 30VDC/0.5A @ 125VAC</p> <p>MONITORING</p> <ul style="list-style-type: none"> LCD Display Volts Amps Status 	<p>MONITORING</p> <ul style="list-style-type: none"> LED Indications Float (Green) Equalize (Yellow) AC ON (Green) Charger Failure (Red) Battery Fault (Red) Current Limit (Yellow) High DC Voltage (Red) Low DC Voltage (Red) Negative Ground Detection (Red) Positive Ground Detection (Red) <p>ENVIRONMENTAL</p> <ul style="list-style-type: none"> Operating -20° to 70°C (derated above 50°C) Storage -40° to 85° C Relative Humidity 5% to 95% non-condensing <p>ENCLOSURE</p> <ul style="list-style-type: none"> Structural Design Wall/Floor Mount NEMA 1 powder coated Cable Entry Both sides <p>STANDARDS</p> <ul style="list-style-type: none"> UL 1012 (pending) CUL (pending) NEMA PE5 C62.41A CE (pending)
---	---	---

Model Number Nomenclature

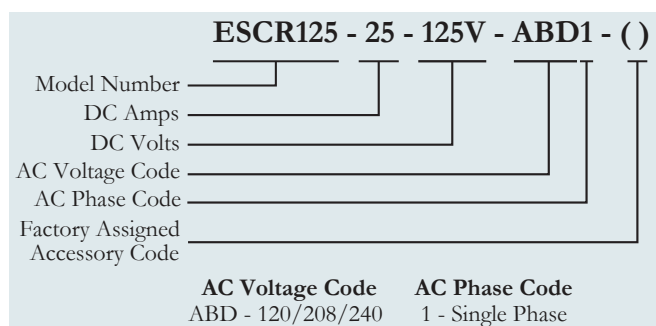

Front Panel Display





SOLAR CHARGE CONTROLLER





SOLAR CHARGE CONTROLLER



The La Marche Solar Charge Controller is available in two models, the SCM (Solar Charge Controller – MPPT Technology) and SCP (Solar Charge Controller – PWM Technology). Both models regulate the voltage and current from the solar modules to properly charge the battery and supply the load. In order to maximize the power that can be extracted from the solar modules, the SCM Controller utilizes Maximum Power Point Tracking (MPPT) algorithm. For a simplified version, the SCP controller regulates the charging power using Pulse Width Modulation (PWM).

The Solar Charge Controller is available in 10A and 20A versions with 12/24V auto-select output. Both controller models feature built-in protection for solar modules, batteries and load connections. Additional features include Low Voltage Load Disconnect, Status LEDs, USB connection for diagnostic parameters and an extra set of output terminals for additional loads.

Standard Features

- MPPT/PWM Algorithms
- Intelligent Micro Controller
- High Efficiency
- Compact Design
- Status LED Indicators
- Bonus Power Terminal
- USB Connection
- Temperature Sensor
- Lightning and Surge Protection
- Solar/Battery Reverse Polarity Protection
- Overload and Short Circuit Protection
- Reverse Current Flow From Battery To Solar Module Protection
- 4 Stage Smart Charging:
Bulk, Absorption, Float and Equalize*
- Programmable for Sealed and Flooded Battery Types
- Low Voltage Load Disconnect (LVLD)

* For Flooded Batteries

TECHNICAL SPECIFICATIONS

		SCM (MPPT)	SCP (PWM)
ELECTRICAL	Nominal System Voltage	12V/24V	
	Output Current (A)	10A 20A	10A 20A
	Nominal Max. Input Power	170W (12V) 340W (12V) 340W (24V) 680W (24V)	170W (12V) 340W (12V) 340W (24V) 680W (24V)
	Max. PV Open Circuit Voltage (Voc)	75V	
	Min. Solar Input Voltage (Voc) @ Start-up	15V	
	Solar Panel Recovery Voltage	17V	
	Battery Voltage Range	6V-15V 17V-30V	
	Load Voltage	12V/24V	
	LVL (Selectable)	11V or 11.5V 22V or 23V	
	LVL (Selectable)	12.1V or 12.6V 24.2V or 25.2V	
	Bonus Power Voltage	12V	
	Max. Bonus Power Current	2A	
BATTERY CHARGING	Charging Method	Bulk/Absorption/Float/Equalize	
	Temp. Compensation Coefficient	12V/-30mV/°C and 24V/-60mV/°C	
	Temp. Compensation Range	-30°C to +60°C	

PROTECTION

- **Solar and Load**
 - Overload
 - Short-Circuit
 - High Voltage
 - Reverse Polarity
- **Battery**
 - High Voltage
 - Reverse Polarity
- **Other**
 - Reverse Current at Night
 - Lightning & Transient Surge Protection
 - LVL (Low Voltage Load Disconnect)
 - LVL (Low Voltage Load Reconnect)

LEDs

- LED 1 - Controller On
- LED 2 - Battery Charging
- LED 3 - Load On
- LED 4 - Bonus Power On
- LED 5 - Overload

TERMINALS

- Solar
- Battery
- Load
- Bonus Power
- Temperature Sensor
- USB Connector

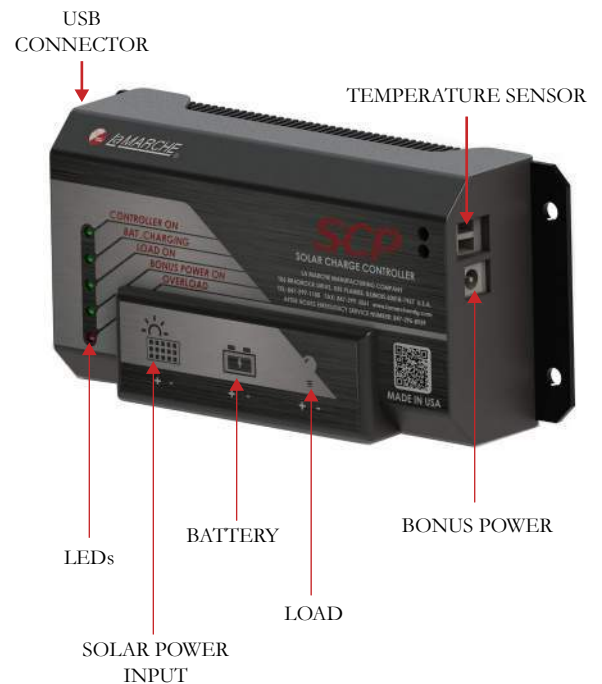

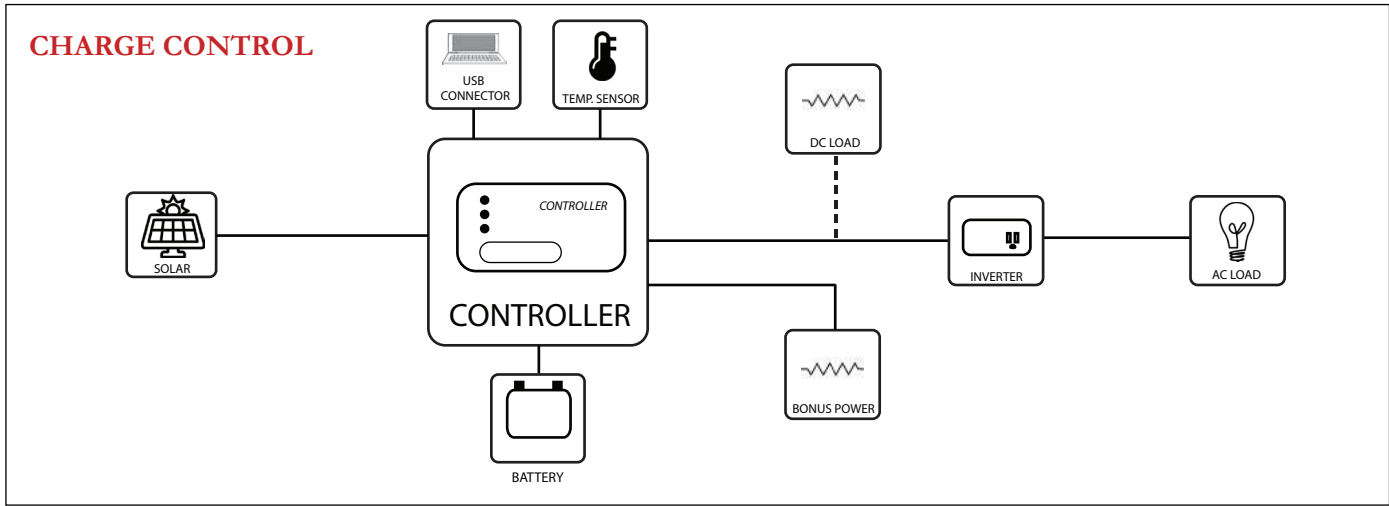

	Model Number	System Rating			Overall dimensions W x D x H	Shipping Weight	
		Power (Nominal)	Volts (Nominal)	Amps		lbs	kgs
PWM	SCP-10-12/24V	170W/340W	12/24V	10	6.75" x 1.75" x 3.00" 171.45 x 44.45 x 76.2mm	1.3	0.6
	SCP-20-12/24V	340W/680W	12/24V	20	6.75" x 1.75" x 3.00" 171.45 x 44.45 x 76.2mm	1.5	0.7
MPPT	SCM-10-12/24V	170W/340W	12/24V	10	6.75" x 1.75" x 3.00" 171.45 x 44.45 x 76.2mm	1.5	0.7
	SCM-20-12/24V	340W/680W	12/24V	20	6.75" x 1.75" x 3.00" 171.45 x 44.45 x 76.2mm	2.0	0.9

USB DIAGNOSTICS PARAMETERS

- Charge On / Off
- PV Volt
- PV Current
- Batt Volt
- Charge state: Bulk, Absorption, Float, Night
- State of Charge (SOC)
- Load On
- Load Current
- Bonus On/Off
- Bonus Power Current
- Remote Temperature

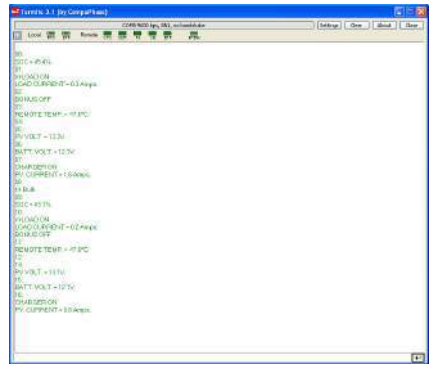

MODEL NUMBER NOMENCLATURE

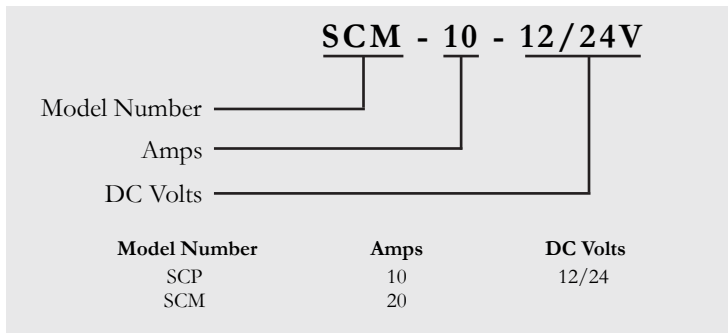

Ordering Specification

When ordering, please specify

- Model Number
- DC Amps
- DC Volts



LaMARCHE

ISO 9001 CERTIFIED

A48/A48B

**CENTRIFUGAL FIRE PUMP BATTERY CHARGERS
USED ON SPRINKLER SYSTEMS**



Model A48 shown above

**FOR CHARGING BATTERIES ON
INTERNAL COMBUSTION ENGINES
DRIVING CENTRIFUGAL FIRE PUMPS
USED ON SPRINKLER SYSTEMS**

The LaMarche A48 and A48B (Base Plate Version) Battery Chargers are specifically designed for maintaining and recharging the dual-battery starting system used on engine driven centrifugal fire pumps for sprinkler systems. Both the A48 and A48B models are available in 12 or 24 Volt DC output for either positive or negative ground starting systems. The Battery Chargers comply with the standard of the National Fire Protection Association (NFPA No. 20).

The controlled magnetic amplifier technology provides the highest reliability that is necessary for the continued operation of emergency standby equipment and eliminates most starting problems by maintaining batteries at full charge, ensuring optimum performance and maximum life.

The A48/A48B is a completely automatic, solid state, constant voltage Battery Charger built to carry continuous and intermittent loads up to 80% of its maximum rated output capacity. It automatically senses the battery and load conditions and delivers the necessary amount of charge.

The A48/A48B Battery Chargers are equipped with a built-in charge divider circuit to isolate and charge two separate sets of batteries of the same nominal DC Voltage either independently or simultaneously. The operation is completely automatic—a voltage sensing relay is provided to

Standard Features

- Magnetic Amplifier Circuitry Provides Increased Longevity and Worry-free Operation
- Automatic AC Input Voltage Compensation $\pm 10\%$
- Automatic Surge Suppression
- AC Input and DC Output Fusing Protects Battery and Charger
- Automatic Float/High Rate Mode Switching
- Float/High Rate Lights (A48 model only)
- Charger Failure Alarm Relay with (1) form "C" Contact
- Automatic DC Voltage Regulation
- DC Current Limiting Circuitry (typically less than 125%) Eliminates the Need for Cranking Disconnect Relay
- 5% Accuracy Analog DC Ammeter & DC Voltmeter (A48 model only)
- Charger Design Prevents Battery from Discharging if AC Line Fails
- Complete Isolation of the AC Line from the DC Charging Circuit
- Environmental:
 - Operating Temperature: 0 to 50°C (32 to 122°F)
 - Storage Temperature: -40 to 85°C (-40 to 185°F)
 - Relative Humidity: 0 to 95% Non-condensing
- AC Input Voltages of 120, 208 or 240, Single Phase, 60Hz
- NEMA 1 Enclosure ANSI 61 Gray Baked Enamel Paint (A48 model only)
- All A48 and A48B models are UL 1236 and CSA Listed
- **Industry's unparalleled 10-year Warranty**

automatically transfer the output of the Battery Charger to the high rate charge mode, after engine cranking or following a power failure. This will bring the batteries to a fully charged state within 24 hours. Once the batteries are fully charged, the relay will automatically transfer the charge rate back to the Float rate to prevent overcharging and protect the batteries.

The A48/A48B Battery Chargers are designed and built for use on Flooded Lead-Acid or Nickel-Cadmium Batteries and are not suitable to charge Sealed Valve-Regulated Batteries since these require output filtering such as a Power Supply (*see our model A12B for this type of application*).

The Controlled Magnetic Amplifier circuitry provides years of trouble-free operation—our confidence in the reliability of our A48/A48B is reflected by our unparalleled and Industry leading 10-year Warranty. The A48/A48B assures the quality, reliability and performance you have come to expect from LaMarche.

A48 / A48B

CENTRIFUGAL FIRE PUMP BATTERY CHARGERS USED ON SPRINKLER SYSTEMS

A48 and A48B Models

Model Number	System Ground	DC Output				AC Input Current Draw @ 100% Load (Amps)*			Case No	Overall Dimensions W x D x H	Cable Entry (when facing unit)		Mounting	Shipping Weight (Approx.)	
		Amps	Volts	Battery Cell Range (choose only one)	Fuse Size	A 120	D 208	B 240			AC input	DC output		lbs	kgs
A48-20-12VP A48-20-12VN	Positive Negative	20	12V	6L 9 or 10 NC	50A	7.1	4.1	3.5	7	14.250 x 10.625 x 19.875" 362 x 270 x 505 mm	Right	Left	Wall / Floor	75 75	34 34
A48-20-24VP A48-20-24VN	Positive Negative	20	24V	12L or 20 NC	50A	15	8.1	7.1	7	14.250 x 10.625 x 19.875" 362 x 270 x 505 mm	Right	Left	Wall / Floor	95 95	43 43
A48B-20-12VP A48B-20-12VN	Positive Negative	20	12V	6L 9 or 10 NC	50A	7.1	4.1	3.5	7B	19.875 x 9.000 x 14.250" 505 x 229 x 362 mm	N/A	N/A	Base Plate	55 55	25 25
A48B-20-24VP A48B-20-24VN	Positive Negative	20	24V	12L or 20 NC	50A	15	8.1	7.1	7B	19.875 x 9.000 x 14.250" 505 x 229 x 362 mm	N/A	N/A	Base Plate	75 75	34 34

*AC Current Draws based @ 100% load and standard battery cells of 6L(12V) and 12L(24V)
All above models designed for optimal performance at 60Hz. They will operate at 50Hz with reduced performance. Consult factory for units designed specifically at 50Hz.
Must specify only one battery type and number of cells. Please consult factory for other available cell ranges if desired range not shown.
Maximum Current Draw is typically 125% of ratings shown.
Other Sizes Available - Contact Factory for further information

Base Plate Photo

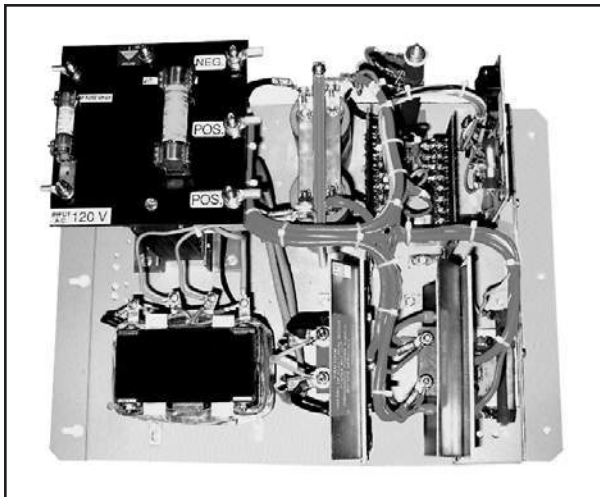

Ordering Information

When ordering, please specify:

- LaMarche Model Number A48 or A48B (Base Plate)
- Input Voltage of 120, 208 or 240 VAC/Single Phase/60Hz
- Number and Type of Battery Cells
- A.H. Capacity of Batteries
- Intermittent DC Loads and Duration
- Continuous DC Load
- Allowable Recharge Time from Full Discharge (where applicable)

Model Number Nomenclature

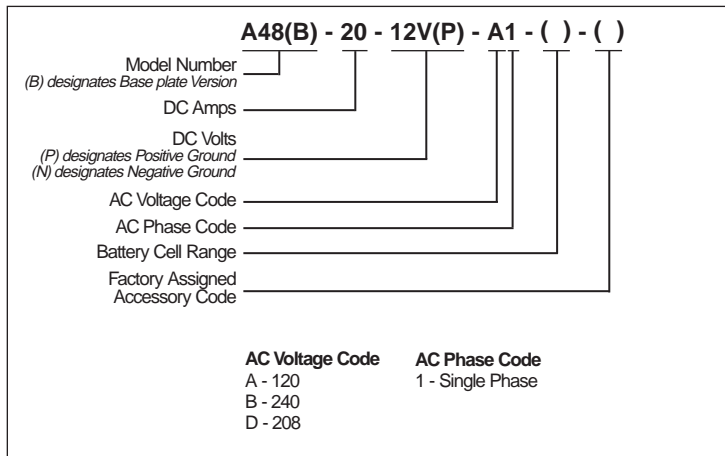

Specifications subject to change without notice

P25-DSA48_A48B-1
ECN: 18250
04-09



106 Bradrock Drive, Des Plaines, IL 60018-1967
Tel: 847-299-1188 Toll Free Fax: 1-888-232-9562
sales@lamarchemfg.com www.lamarchemfg.com



LaMARCHÉ®

ISO 9001 CERTIFIED

A63
DC-DC CONVERTER SYSTEMS



19" and/or 23" PC63 Cage shown above with (2) A63 Converters and a TPCDB1 Distribution Module

A63 DC-DC CONVERTER SYSTEMS

The unique design of the LaMarche A63 Series DC-DC Converters will allow you to utilize your 48V, 24V, and/or 12V equipment at a site where 130V batteries are installed. This will save battery, charger, and installation costs as well as reducing maintenance time and optimizing space. The A63 is a compact self contained DC-DC Converter that provides the Modular Power that today's utility substation, process control and telecommunications applications require. The A63 is the building block of these reliable systems using advanced switching technology. Its filtered output provides the clean power required for sensitive loads.

Typical System Diagram

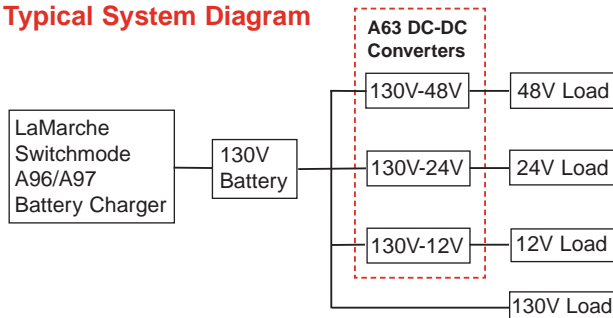

The A63 DC output is available in 48V (15 amps) and 24V (30 amps) rated at 750W, or 12V (30 amps) modules rated at 375W. The converter modules are hot-swappable plug-in type. Installation or replacement is swift, simple, and achieved without affecting the integrity of the system.

Its versatile design allows the DC output to be wired as a single connection for all converters or for each pair of converters per cage. This allows for custom field installations and gives greater system flexibility to suit the customer needs and preferences.

A63 Converter Systems are factory configured with one to four Modules in a single cage. Distribution Modules consisting of either GMT Fuses (TPCD) or Breakers (TPCDB1) can share a cage with the converters to form a complete Power System.

Rely on LaMarche quality, reliability and performance to power your present and future system needs.

Standard Features

- High Frequency Switchmode Circuitry Provides High Power Density
- Hot Plug-In Feature Provides Easy Replacement Without Disturbing System Operation
- 48VDC and 24VDC Versions—750 Watts Output Power
- 12VDC Version—375 Watts Output Power
- 19" and 23" Rack Mounting (using PC63 cages)
- Nominal Input Voltage of 130VDC, Range from 105-150VDC
- DC Input Breaker Mounted on Cage for Each Converter Module (wired in positive leg)
- Output Voltage Adjustment Potentiometer
- Test Points for Measuring Output Current and Voltage Using a Precision Multi-Meter
- Current Limiting Circuitry of 105% Maximum (factory set)
- Filtered/Battery Eliminator Design—less than 150mVp-p, 32db_{rn} "C" Message Weighted
- 82% Efficiency within 50 to 100% of Rated Load
- Load Sharing Circuitry (10% of rated load)
- Soft Walk-In Circuit
- Over Temperature and Voltage Protection
- Converter Failure Alarm with (1) Set of Form "C" Contacts with Light (Alarm will Initiate for either Low Voltage, High Voltage Shutdown, Low DC Current, Converter Failure or DC Breaker Tripped)
- 2-Year Limited Warranty

Electrical

DC Input

Voltage Range
105-150VDC

Protection

DC Breaker provided on cage for each unit

DC Output

Adjustable Output Voltage Range

48 to 58VDC on 48V models
24 to 29VDC on 24V models
12 to 14.5VDC on 12V models

Power

750W per 48VDC and 24VDC module,
maximum 3000 Watts per cage
375W per 12VDC module, maximum 1500
Watts per cage

Voltage Regulation

± 0.6% Total DC Voltage Regulation
(Measured at converter side of blocking diode)

Current Limit

105% of rated output maximum (factory set)

Load Sharing

Load Sharing Circuitry (10% of rated load)

Protection

Over Voltage, Over Temperature

Efficiency

82% within 50-100% of rated load

Ripple and Noise

Less than 150mV peak to peak, 32db_rn
"C" message weighted

Test Points

For output current and output voltage using
a precision digital voltmeter

Environmental

FCC Approved Part 15, Subpart B, Class A
IEC-555-2 Compliant

Operating Temperature:

0 to 50° C (32 to 122° F)

Storage Temperature:

-40 to 85° C (-40 to 185° F)

Relative Humidity:

0 to 95% (non-condensing)

Altitude:

0 to 3,000 meters (10,000 ft)

A63 Modules

Model Number	DC Output Amps	DC Output Volts	DC Input Voltage Range	Typical DC Input Current Draw @ 100% Load (Amps)
A63-15-48V-130V	15	48	105-150	9
A63-30-24V-130V	30	24	105-150	9
A63-30-12V-130V	30	12	105-150	5

PC63 Cages

Model Number	Description	No of Available Bays	DC Output Amps	DC Output Volts	Rack Mounting
PC63-60-48V-130V	1-4 modules	4	60	48	19"/23"
PC63-120-24V-130V			120	24	19"/23"
PC63-120-12V-130V			120	12	19"/23"
PC63-30-48V-130V	1-2 modules with TPCD or TPCDB1	2 +1	30	48	19"/23"
PC63-60-24V-130V			60	24	19"/23"
PC63-60-12V-130V			60	12	19"/23"

Units can be mounted flush with the rack or moved forward 5 inches (127mm).
Allow an additional 0.75 inches (19mm) for handles.

Enclosures

A63 DC-DC Converters

Dimensions

3.25"W x 11.0"D x 5.25"H
(83x279x133 mm)

Weight

7 lbs each (3.2 kgs)

Mounting

19"/23" Rack Mount PC63 Cages

PC63 Cages

Dimensions for 19" or 23" Rack

18.25"W x 15.29"D x 8.75"H
(464x388x222 mm)

Weight

26 lbs

Mounting

PC63= 5 RU's

Agency Approvals

U.L. Recognized Component

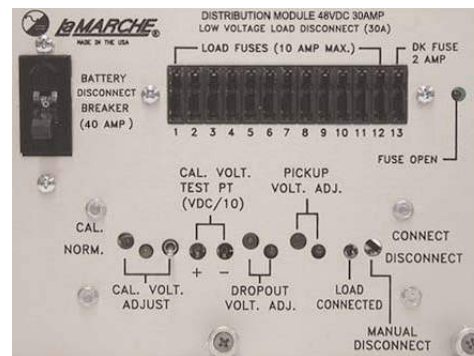

TPCD Distribution Module - GMT Fuses (For further details on this product refer to the TPM Systems Data Sheet)

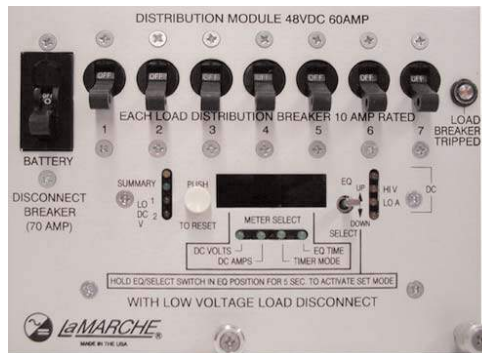

TPCDB1 Distribution Module - Breakers (For further details on this product refer to the TPM Systems Data Sheet)

Specifications subject to change without notice

P25-DSA63-1
ECN 15678
12-025



LaMarche Manufacturing Company
106 Bradrock Drive, Des Plaines, IL 60018-1967
Tel: 847-299-1188 Toll Free Fax: 888-232-9562
sales@lamarchemfg.com www.lamarchemfg.com



Unit shown with optional 1ms Static Transfer Switch & Digital Display

A31 DC-AC Inverter

The La Marche A31 Inverter is the ideal choice when AC power requirements are critical. This inverter has a wide range of standard features such as a sine wave output, voltage regulation, protection from AC-DC shorts, under/over-voltage conditions, input filtering and overload protection. It incorporates a DC input breaker and an automatic under/over-voltage shutdown circuit to protect the inverter. The A31 has a polarity indicator to tell you if the battery is connected incorrectly. The unit is equipped with an input filter pre-charge circuit which includes an indicator to inform you that the inverter is ready for operation. Applications may include data centers, fire alarms, telecommunications, emergency lighting, security, oil exploration and utility substation systems.

Available in 50 or 60 Hz 120, 240, 208 or 220 AC Output.

Standard Features

- Highly Reliable Ferroresonant Transformer
- Available DC Inputs 24V or 48V or 120V
- DC to AC Isolation
- Pure Sine Wave Output
- Adjustable DC Under/Over Voltage Shutdown
- Analog AC Ammeter & Voltmeter (2%)
(Optional on 250 VA & 500 VA)
- Overload/Current Limit
- Inverter On/Off Switch
- AC Circuit Breaker
- DC Circuit Breaker
- IGBT Power Block Technology
- UL 1012 Listed, UL 1481 Listed (selected models)
and C-UL Listed
- 5-Year Limited Warranty

Options

- 22P** 1ms Static Transfer Switch (Inverter Prime)
(available on 1KVA and larger)
- 22S** 1ms Static Transfer Switch (Inverter Standby)
(available on 1KVA and larger)
- 22A** Static Switch Alarm Package consisting of the following: 2 Form "C" Contacts for Phase Lock, Utility Available, Inverter Available, Load on Preferred, Load on Alternate, Requires 22P or 22S.
- 22D** Digital Display (replaces AC analog meters). Used only with 1ms Static Switch. Requires 22P or 22S.
- 09A** UL 1481
- 164** 10-15ms Static Switch Transfer (Inverter Prime)
(not available on 4KVA & above)
- 165** 10-15ms Static Switch Transfer (Inverter Standby)
(not available on 4KVA & above)
- 130** Inverter Failure Relay and Light (not available with option 22A)
- 132** Inverter Failure Relay (1 Form "C") (not available with option 22A)
- 133** Utility Available Relay (1 Form "C") (not available with option 22A)
- 123** Duplex Receptacles (not UL Listed)
- 06L** AC Ammeter (Std. on 750 VA and larger)
- 06M** AC Voltmeter (Std. on 750 VA and larger)
- 06C** DC Ammeter (2%)
- 06D** DC Voltmeter (2%)

TABLE OF CONTENTS

Model Number	DC Input Amps		AC Output			BTU Hour***	Case No.	Approx. Weight	
	No Load	Full Load***	VA	Volts	Amps			lbs	kgs
A31-250-24V-A6	3.0	16.0	250	120	2.08	294	39	60	27
A31-500-24V-A6	5.0	28.0	500	120	4.17	301	39	75	34
A31-750-24V-A6 ^(†)	6.0	44.0	750	120	6.25	595	33	80	36
A31-1K-24V-A6 ^(†)	11.0	59.0	1000	120	8.33	817	9D	105	48
A31-1.5K-24V-A6 ^(†)	12.0	87.0	1500	120	12.50	1118	9D	120	55
A31-2K-24V-A6 ^(†)	17.0	116.0	2000	120	16.67	1491	9E*	175	80

Model Number	DC Input Amps		AC Output			BTU Hour***	Case No.	Approx. Weight	
	No Load	Full Load***	VA	Volts	Amps			lbs	kgs
A31-250-48V-A6 ^(†)	2.0	9.0	250	120	2.08	308	39	60	27
A31-500-48V-A6 ^(†)	2.5	15.0	500	120	4.17	445	39	75	34
A31-750-48V-A6 ^(†)	3.5	22.0	750	120	6.25	595	33	80	36
A31-1K-48V-A6 ^(†)	5.0	28.0	1000	120	8.33	602	9D	105	48
A31-1.5K-48V-A6 ^(†)	7.0	40.0	1500	120	12.50	616	9D	120	55
A31-2K-48V-A6 ^(†)	10.0	54.0	2000	120	16.67	917	9E*	175	80
A31-3K-48V-A6 ^(†)	13.0	81.0	3000	120	25.00	1375	9E*	270	123
A31-4K-48V-A6 ^(†)	15.0	106.0	4000	120	33.33	1546	9E*	310	141
A31-5K-48V-A6 ^(†)	16.0	132.0	5000	120	41.67	1860	9E*	340	155
A31-10K-48V-A6	29.0	278.0	10000	120	83.33	5732	44**	800	364

Model Number	DC Input Amps		AC Output			BTU Hour***	Case No.	Approx. Weight	
	No Load	Full Load***	VA	Volts	Amps			lbs	kgs
A31-250-120V-A6	1.0	3.0	250	120	2.08	222	39	60	27
A31-500-120V-A6	1.8	6.0	500	120	4.17	445	39	75	34
A31-750-120V-A6	2.0	9.0	750	120	6.25	667	33	80	36
A31-1K-120V-A6	4.0	11.0	1000	120	8.33	730	9D	105	48
A31-1.5K-120V-A6	4.5	17.0	1500	120	12.50	975	9E*	120	55
A31-2K-120V-A6	5.0	22.0	2000	120	16.67	1060	9E*	175	80
A31-3K-120V-A6	6.0	32.0	3000	120	25.00	1231	9E*	270	123
A31-4K-120V-A6	8.0	42.0	4000	120	33.33	1402	9E*	310	141
A31-5K-120V-A6	9.0	52.0	5000	120	41.67	1573	9E*	340	155
A31-7.5K-120V-A6	10.0	79.0	7500	120	62.5	2719	72**	500	227
A31-10K-120V-A6	12.0	105.0	10000	120	83.33	3506	72**	800	364
A31-15K-120V-A6	25.0	162.0	15000	120	125.00	6874	44**	950	432

Case No.	Case Type			RU	Height		Width****		Depth	
	Floor	Relay Rack			in	mm	in	mm	in	mm
		19"	23"							
39	N/A	✓	✓	4	7.0	178	16.75	425	16.25	413
33	N/A	N/A	✓	6	10.50	267	21.00	533	16.25	413
9D	N/A	N/A	✓	10	17.50	445	20.88	530	18.00	457
9E	N/A	N/A	✓	10	17.50	445	20.88	530	23.00	584
70	✓	N/A	N/A	N/A	41.00	1041	27.00	686	19.00	483
72	✓	N/A	N/A	N/A	44.50	1130	27.00	686	23.50	597
44	✓	N/A	N/A	N/A	72.10	1831	24.00	610	19.06	484

* Requires a heat battery when 2 or more units are used.
 ** Floor mount case only (all others are rack mounted).
 *** Typical at full load and minimum input voltage.
 **** Main body width of case on relay rack units. Side mounting angles located 7.50" from front of relay rack.
 (†) UL 1481 Listing Available

Input Specifications

- Battery Ranges**
24 volt nominal 21-30VDC
48 volt nominal 42-60VDC
120 volt nominal 105-150VDC
- Input**
Reverse Polarity Protection Indicator
Filter Pre-charge Circuit; DC Breaker
- DC Under Voltage Shutdown**
Adjustable
- DC Over Voltage Shutdown**
Adjustable

Output Specifications

- AC Output Voltage**
120V Nominal (Standard)
240V (Optional)
208V and 220V (Optional, Not UL Listed)
- Output Power**
Rated VA continuous for unity to .8
lagging power factor
- Line Regulation**
±3% Over DC Battery Range

- Load Regulation**
±4% from no load to full load
- Frequency Regulation**
±0.5% (Quartz Clock)
- Current Limit**
Approximately 150%. Protected by AC Output Breaker
- Total Harmonic Distortion**
Approximately 5% at nominal DC Input and Full Load. Less than 3% for any single harmonic.
- Noise**
Less than 32 dBm "C" message weighted with a battery (24VDC and 48VDC only).
- Audible Noise**
65 dB @ 5 feet
- Approximate Efficiency**
24VDC models 70-75%
48VDC models 85-90%
120VDC models 85-90%
- Load Crest Factor**
Will operate with Load Crest Factors up to 2.8

Environmental

- Operating Temperature**
0 to 50°C
- Storage Temperature**
-20 to 60°C
- Relative Humidity**
0-95% (non-condensing)
Convection Cooled (3KVA and larger units may be fan assisted)

Agency Approvals

- UL 1012
UL 1481 (Available for selected models, refer to chart)
- C-UL

Ordering Information

- When ordering, please specify:**
- La Marche Model Number A31 Inverter
 - Desired output power (VA)
 - Battery type and number of cells
 - Output voltage and frequency
 - Description of load
 - Optional Accessories

22P / 22S Static Switch

1MS Electronic Transfer Switch

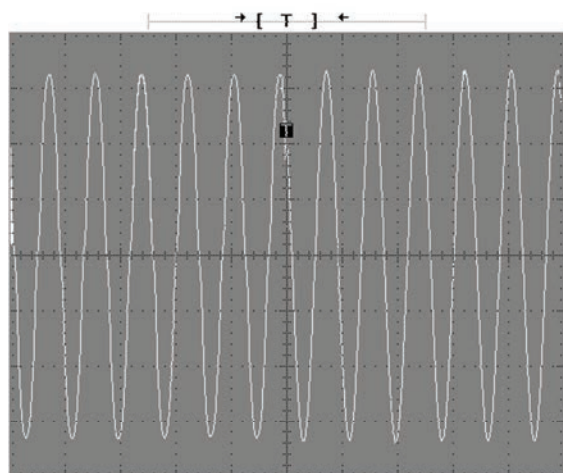

Frequency 60.0Hz 50.0V/DIV 20.0ms/DIV **T** indicates when transfer occurs
 Scope photo shown above of typical Static Switch Transfer from Inverter Prime Source to Alternate Source upon loss of Inverter Output

Fast Electronic Static Switch for La Marche A31 DC to AC Inverter

The La Marche Electronic Static Switch is an automatic device that will transfer an AC load to and from the Prime Source to an Alternate Source, if the Prime Source fails, in less than 4 millisecond. The Static Transfer Switch is intended for use on the La Marche A31 DC to AC Inverters ranging from 1kVA to 15kVA models (consult factory for other applications). A customer calibration mode is incorporated into the Static Switch Menu to allow for on site settings that are best suited for the intended application.

A Digital Display Panel, which replaces the unit's AC analog meters, is also offered as an option. The Digital Display will allow the operator to view Load Voltage, Load Current, VA (Volt-Amps), Utility Voltage, Utility Frequency, Inverter Voltage and Inverter Frequency readings.

Status Display

A Status Display panel consisting of (5) LED indicator lights and (2) switches are provided on the front of the unit.

- | | |
|---|---|
| <ul style="list-style-type: none"> ⊗ Phase Lock ⊗ Utility Available ⊗ Inverter Available ⊗ Load on Preferred Source ⊗ Load on Alternate Source ▶ Auto/Manual Switch ▶ Test Transfer Pushbutton | <ul style="list-style-type: none"> ▶▶ Indicates when the Prime and Alternate sources are in synchronization ▶▶ Indicates the Alternate source is connected and operating within its proper range ▶▶ Indicates the Inverter is operating within its proper range ▶▶ Indicates the AC load is operating on the Prime source ▶▶ Indicates the AC load is operating on the Secondary source ▶▶ Allows for an Automatic or Manual Transfer ▶▶ Allows an active check of the Static Switch operation |
|---|---|

Customer Calibration Mode

The customer calibration mode allows the user to select the available parameters and to set per preferences.

- | SELECTIONS | SETTINGS |
|------------------------------------|---|
| 1. Preferred Source | ▶▶ May be selected to either Utility or Inverter |
| 2. Load Voltage Window Upper Limit | ▶▶ Maximum voltage allowed on the Load |
| 3. Load Voltage Window Lower Limit | ▶▶ Minimum voltage allowed on the Load |
| 4. Utility Voltage Upper Limit | ▶▶ Maximum voltage allowed for Utility to be considered good |
| 5. Utility Voltage Lower Limit | ▶▶ Minimum voltage allowed for Utility to be considered good |
| 6. Inverter Voltage Upper Limit | ▶▶ Maximum voltage allowed for Inverter to be considered good |
| 7. Inverter Voltage Lower Limit | ▶▶ Minimum voltage allowed for Inverter to be considered good |
| 8. Inverter Sense Delay | ▶▶ The amount of time the Inverter must be within the upper and lower limits before the Inverter is considered within tolerance |
| 9. Utility Sense Delay | ▶▶ The amount of time the Utility must be within the upper and lower limits before the Utility is considered within tolerance |
| 10. Retransfer Delay | ▶▶ Used to set the time the Static Switch will attempt retransfer from the Alternate Source to the Primary Source |
| 11. Hit Counter | ▶▶ Used to determine the maximum allowable load voltage deviations outside of the pre-defined envelope that will trigger a transfer |

Static Switch Options

Option #22A Alarm Relay Board consisting of (2) sets of Form "C" Contacts for each of the following:

- Phase Lock
- Utility Available
- Inverter Available
- Load on Prime Source
- Load on Alternate Source

Option #22D Digital Display (replacing AC analog meters on unit) to indicate the following:

- Load Voltage
- Load Current
- VA (Volt -Amps)
- Utility Voltage
- Utility Frequency
- Inverter Voltage
- Inverter Frequency

Manual Bypass Switch

For AC Applications



*Back Cover Not Shown

Manual Bypass Switch

The Manual Bypass Switch (MBS) provides a mechanical means to transfer between power sources to your critical loads. Whether you are performing regular schedule maintenance on the system or in the event of an unexpected system malfunction, the power to the load can be safely transferred without being interrupted.

La Marche offers two types of MBS configurations, a Make-Before-Break (MB4B) and a Break-Before-Make (BB4M). The MB4B switch links both primary and secondary sources momentarily before completing the transfer. The MB4B is the preferred configuration for use with critical loads.

Rack Panel	Inverter Rating	Rack Units
20A	250 TO 1.5kVA	2
45A	2k to 4kVA	3
75A	5kVA	4
200A	7.5 to 15kVA	8

Wall Mount	Inverter Ratings	Case No.	Width		Depth		Height	
			in	mm	in	mm	in	mm
20A	250 TO 1.5kVA	1	10.375	264	7.875	200	16.250	413
45A	2k to 4kVA	1	10.375	264	7.875	200	16.250	413
75A	5kVA	2	12.812	326	10.000	254	17.125	435
200A	7.5 to 15kVA	3	15.375	391	11.000	279	23.750	603

Standard Features

- Input & Output Terminal Block
- Rotary CAM Type Switch
- 2- Position for Complete Isolation
- Rack or Wall Mount available
- UL Listed Bypass Switches
- 20 to 200 AMP Rating Switches

Option

- 06J - Frequency Meter (available for MB23 & MBW)

Model Number Nomenclature

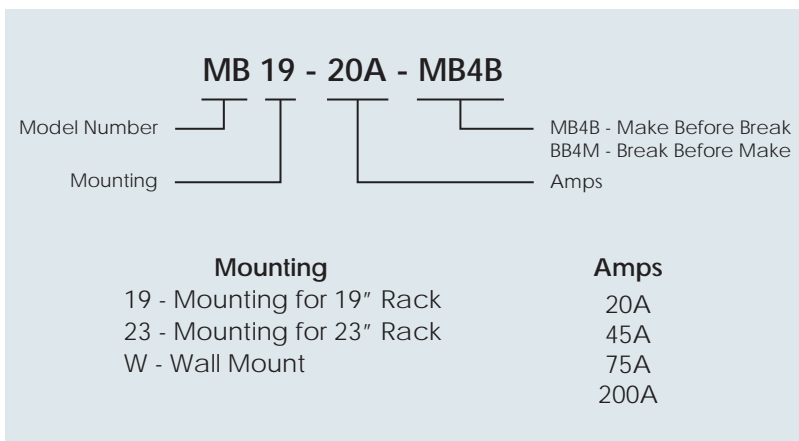

Note: For use on 120 VAC Inverters. For other AC Voltages consult factory.



Fully Equipped 3KVA System with Optional SNMP Module



IX Series

This IX Inverter Series offered by La Marche Manufacturing is designed to operate from a 48VDC (40.5-58V range) input and produce either 120VAC or 230VAC nominal output at up to 6kVA total capacity. The low distortion 50 or 60 Hz sine wave is produced using an advanced DSP controlled architecture which achieves better than 89% efficiency and 10.5VA per cubic inch power density.

The IX Series pre-configured inverter systems include a Controller, Static Transfer Switch, Power distribution and Maintenance by-pass facilities. Remote communications to a PC is provided via USB, RS232 or RS485 serial connections. SNMP alarm traps delivered over an Ethernet TCP/IP connection are also available as an option.

Inverter Modules

Output Power	Output Voltage	Output Frequency ¹	Model Number
1500VA @ 0.8PF 1200W @ 1PF	120VAC	60Hz (50Hz)	INV1548-LMC-1
	230VAC	50Hz (60Hz)	INV1548H-LMC-1

Notes:
1. The frequency shown in parenthesis can be obtained by reprogramming the unit from the system controller.

Standard System Configurations

Model Number ³	Max. Output Power		Max. No. Modules	Output Voltage ¹	Output Frequency ²	Network Module	Distribution Socket Type	Manual Bypass	Rack Height
IX4U-1-TS50-D2E-M-LMC-1	3KVA	2.4kW	2	120VAC or 230 VAC	60Hz / 50Hz	---	8 x IEC60-320	YES	4U
IX4U-1-TS50-D2N-M-LMC-1	3KVA	2.4kW	2	120VAC or 230 VAC	60Hz / 50Hz	---	8 x NEMA 15-5 ⁴	YES	4U
IX5U-2-TS50-D2E-M-LMC-1	6KVA	4.8kW	4	120VAC or 230 VAC	60Hz / 50Hz	---	8 x IEC60-320	YES	5U
IX5U-2-TS50-D2N-M-LMC-1	6KVA	4.8kW	4	120VAC or 230 VAC	60Hz / 50Hz	---	8 x NEMA 15-5 ⁴	YES	5U
IX4U-1-TS50S-D2E-M-LMC-1	3KVA	2.4kW	2	120VAC or 230 VAC	60Hz / 50Hz	✓	8 x IEC60-320	YES	4U
IX4U-1-TS50S-D2N-M-LMC-1	3KVA	2.4kW	2	120VAC or 230 VAC	60Hz / 50Hz	✓	8 x NEMA 15-5 ⁴	YES	4U
IX5U-2-TS50S-D2E-M-LMC-1	6KVA	4.8kW	4	120VAC or 230 VAC	60Hz / 50Hz	✓	8 x IEC60-320	YES	5U
IX5U-2-TS50S-D2N-M-LMC-1	6KVA	4.8kW	4	120VAC or 230 VAC	60Hz / 50Hz	✓	8 x NEMA 15-5 ⁴	YES	5U

Notes:
1. Inverter modules must be ordered separately based on output voltage and total system capacity required. Module types may not be mixed in the same system.
2. 120VAC inverters are pre-programmed to 60Hz, 230VAC inverters are pre-programmed to 50Hz. These settings can be changed from the front panel of the controller or remotely using the WIN-power client application.
3. "M" = Mid Mounting
4. Provided via IEC to NEMA adapters

Standard Features

- Hot-Swap Inverter, STS and Controller Modules
- 19 inch Rack Mounting
- 1500 to 6000 VA System Capacity
- 120VAC or 230VAC
- Low Distortion 50 or 60Hz Pure Sine Wave
- 40.5 to 58 VDC Input

- DSP Management & Control
- > 89% Efficiency
- 1-year Warranty

Optional Features

- 23 inch Rack Mounting Kit

SPECIFICATIONS

Typical at 48V Input, Full Load and 25°C Unless Otherwise Noted.

INVERTER MODULES

INPUT

Voltage Range	40.5-58VDC
Undervoltage Warning Threshold	45VDC
Undervoltage Threshold	40VDC
Overvoltage Warning Threshold	58VDC
Overvoltage Threshold	60VDC
Input Current, 48VDC Input	28.4A
Input Protection	Fused Reverse Polarity Protection
Inrush Current	Less than 2x Rated I _{in} (IEC62040-3-1999)
Isolation	
Input to Output	Reinforced Pri-Sec, 4242VDC / 1 min.
Input to Ground	707VDC (Varistor & filter caps removed)
Psophometric Noise Voltage	<1mV ITU-T 0.41 (16.66-6000Hz)
Reflected Psophometrics Noise Current	<1% YD/T 777-2006
Reflected Relative Band Wide Current	<10% YD/T 777-2006 (0-2MHz)
Wide Band Noise	<20mVrms (25Hz-20kHz)
Peak to Peak Noise	<150mV up to 100MHz

OUTPUT

AC Waveform	Pure Sine Wave
Output Power	1500VA @ 0.8PF OR 1200W @ 1PF
Power Factor or Load	-0.8 to +0.8
Rated Output Voltage	120VAC or 230VAC (see model table)
Output Voltage Variation	<±2%
Output Frequency	50Hz or 60Hz (see model table)
Frequency Variation	<±0.5%
Crest Factor	3:1 max.
THD of Voltage Waveform	
Linear Load	<3%
Non-Linear Load	<5%
Capacitive/Inductive Load	+0.8 to +0.8 PF
without exceeding permissible distortion for resistive load	
Efficiency	>89%
Overload Protection	Electronic Current Limit at Overload & Short Circuit
1.25 x Rated Current, Temperature Controlled	
1.50 x Rated Current for Periods <20 Seconds	
Dynamic Response	<±10%
Isolation, Output to Chassis	Basic Isolation (Pri-Gnd) 2121 VDC/1 min.
Surge Protection	EN61000-4-5
Telcordia GR-1089 Core ANSI C62.41-IEEE, STD 587-1980	
Load Sharing	<5% of Rated Load

CONTROL/STATUS

LED Indicators	
Inverter Status	Green OK, Red FAIL
Overload	Off OK, Yellow for Overload
Reverse Polarity	Off OK, Red for Reversed
Status/Alarm Information (via controller)	Inverter Fail, Overload, LVD Alarm, Fail Alarm, Thermal Derating, Power Output, Input Voltage, Output Voltage, Output Current, Output Frequency, Low Input Voltage Shutoff, Inventory Data.
Runtime Info.	Through Maintenance Feature in Controller

STATIC TRANSFER SWITCH (STS)

INPUT

Voltage Range	
110/115/120VAC Systems	89-138VAC
208/220/230/240VAC Systems	176-276VAC
Over / Undervoltage Threshold (adjustable from controller)	
110VAC Systems	117 to 127VAC / 89 to 105VAC
115VAC Systems	122 to 132VAC / 93 to 110VAC
120VAC Systems	127 to 138VAC / 100 to 114VAC
208VAC Systems	220 to 240VAC / 176 to 198VAC
220VAC Systems	233 to 252VAC / 176 to 209VAC
230VAC Systems	244 to 264VAC / 185 to 218VAC
240VAC Systems	254 to 276VAC / 193 to 228VAC

OUTPUT

AC Waveform	Sine Wave
Output Voltage	Same as utility or inverter modules
Permissible Frequency Variation to Synchronise Inverters	±2.5%
Transfer Time	Typically 1/4 cycle
Rated Current	50A
Operation Modes (programmable)	Inverter Priority or Utility Priority
Default Priority	Inverters

CONTROL/STATUS

LED Indicators	
Fault (red)	Off OK, On FAIL
Warning (yellow)	Off OK, Flashing for warning condition
Power On (green)	On OK, Flashing for bypass
Status/Alarm Information	CAN communication failure
back-feed relay open, SCR short, output short, overload	
over temperature, mains unavailable, inverter unavailable	
output abnormal, fan failure, MBS position error	

GENERAL

ENVIRONMENTAL

Operating Temp. Range	
Without Derating	-5°C to 50°C
With Derating	-20°C to 70°C
Storage Temp. Range	-40°C to +85°C
Humidity	0% to 95%, Non-Condensing
Cooling	Variable Speed Internal Fans (Field Replaceable)
Operating Altitude	1500m without derating

REGULATORY

Safety	
Inverter/PDU/MBS/chassis	UL60950-1, EN60950-1, IEC60950-1
STS module	UL1778
EMC (individual modules)	EN300 386:2001 Class B
Acoustic Noise (individual modules)	55dB ETS300 753, Class 3.1

Safety Standards

UL60950-1
 CSA22.2, No. 60950-1
 EN60950-1

IFC1000 Standard Interface Module

The IX Series Standard Interface Module provides system connection to a computer via RS232, RS485 or USB for the purposes of remote monitoring, control or programming. Remote PC based software provides a user friendly GUI interface.

The Network Interface Module with SNMP (integral to the STS/Controller shelf) provides alarm traps over a TCP/IP Ethernet interface.



Standard Interface Module



Network Interface Module with SNMP

DSC2048 Controller Module

The IX Series Controller, allows the user to monitor real-time system status such as output voltage, output current, alarm status, and also allows system parameters to quickly be changed with the touch of a few keys on the front panel. With the Communications Interface Module installed remote access can be made with a PC over a variety of interfaces.



- Compact design (1RU height)
- RS-232
- RS-485
- SNMP
- USB
- CAN bus interface embedded
- Programmable dry contact
- Hot swappable
- Real time clock embedded
- LCD and LED indicator
- Audible alarm

DPMBS2U Manual Bypass / Distribution Module

The IX Series manual bypass and power distribution module enables the user to manually switch between inverter output or utility output and to override the STS module for maintenance purposes. A mechanical interlock between the DPMBS2U and the STS module ensures that AC to the load cannot be inadvertently interrupted.

The DPMBS2U provides two means of distributing AC to the load as standard; as a single bulk output or via eight IEC320 outlet sockets with Magnetic Circuit Breakers.

- Bypass switch
- Enables hot-swap of STS module
- 50A bulk output on terminal block
- AC utility can be isolated via MCB
- 100A master MCB
- 8 x IEC320-C13 (-E)
- 4 Distribution MCBs



3KVA SYSTEM CONFIGURATIONS

TABLE OF CONTENTS

Rear views are with safety covers removed to show input and output connection details.

IX4U-1-TS50S-D2E-LMC

Bulk AC Output / 8 x IEC60320-C13 Outlets - 120VAC or 230VAC
STS Hot-Swappable using Manual Bypass

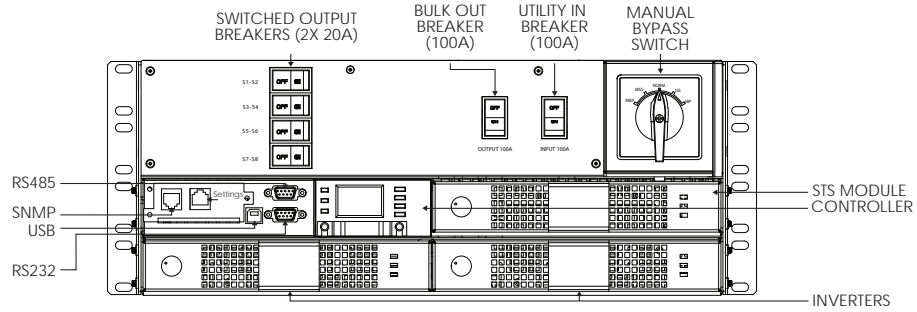

Front View (Shown with optional SNMP Module)

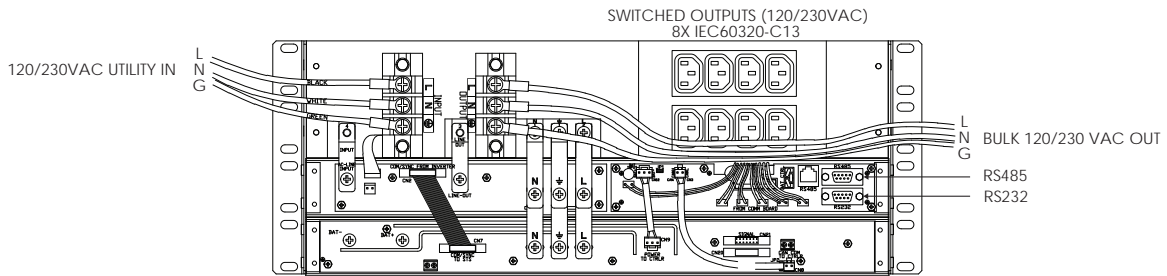

Rear View

6KVA SYSTEM CONFIGURATIONS

Rear views are with safety covers removed to show input and output connection details.

IX5U-2-TS50S-D2E-LMC

Bulk AC Output / 8 x IEC60320-C13 Outlets - 120VAC or 230VAC
STS Hot-Swappable using Manual Bypass

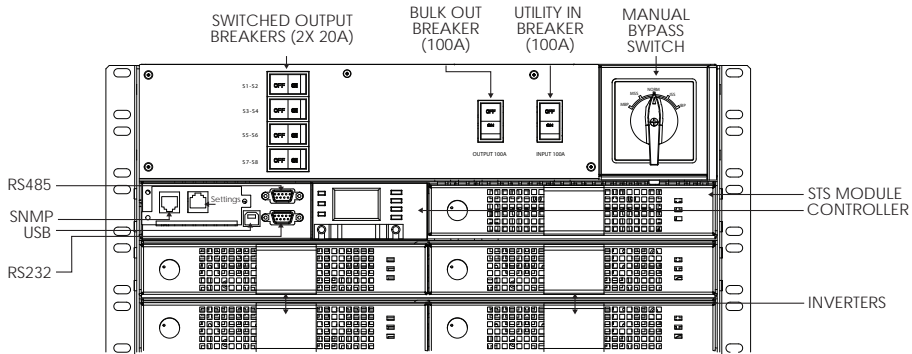

Front View (Shown with optional SNMP Module)

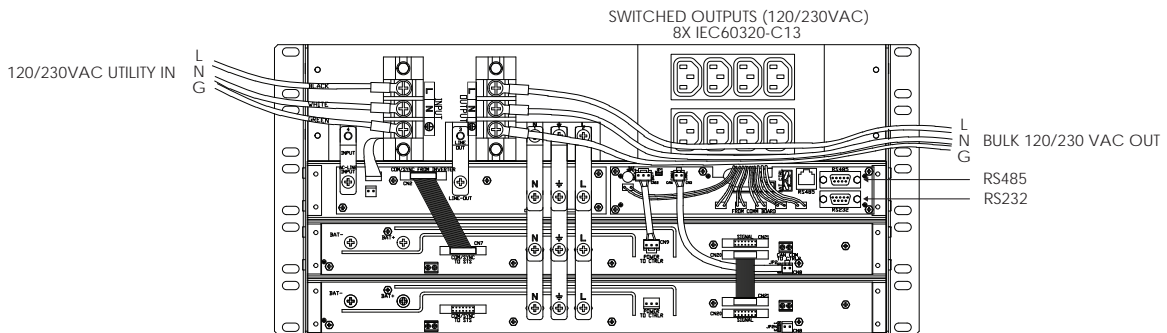

Rear View



STATIONARY BATTERY INFORMER

U.S. PATENT NO. 6,992,487



Shown: BI-100-130V-300-92N

The La Marche Stationary Battery Informer (BI) is a breakthrough in technology. This tester can be installed in any battery system. The BI can determine the condition of your batteries under load without disrupting the system operation. The battery and charger are never disconnected from the load even during the test. The intelligent tester control circuit will not allow testing to take place while the batteries are being used in an emergency situation or if they are recharging from a recent discharge. It will also signal if the tester has failed and/or the charging system is inoperative.

The Battery Informer performs a factory set 1 minute (adjustable to 2 or 3 minutes) patented test to check whether the battery has good, missing, open, or sulfated cells and displays results. If the tester detects suspected sulfation, an automatic equalize cycle can be initiated on a charger equipped with a remote equalize feature. The test can be initiated manually or the controller can be programmed to automatically perform the test periodically.

This patented BI has the capability to store battery discharge curve as a benchmark to analyze battery health trends. The Battery Informer offers an optional DNP3 or MODBUS communication interface. This allows downloadings of test results to a computer and compare with previous test performed on the battery.

The Battery Informer is available in several models covering battery strings of 24, 48 and 130 Volts with capacities ranging from 25 to 1000 ampere hours. Contact the factory for other system ratings.

Standard Features

- Online Battery Test System
- Manual Test Mode
- Programmable Auto Test Interval (Adjustable 1 to 120 day interval) Battery and charger are never disconnected from load
- Automatic Self-Diagnostic
- LCD Display
- LED's provided for:
 - Test Pass
 - Test in Process
 - Manual Test
 - Check Battery System
 - Open Cell Detected
 - Tester Failure
- Relay Contacts - (2) Sets of Form "C" Contacts each
 - Summary Failure Alarm**
 - Remote Auto Equalize Control
 - Charger Inoperative Alarm
 - Tester Failure Alarm
 - Test in Process Relay

** Summary Failure is defined as any of the following Alarms: Open Cell, Possible Battery or Tester Failure.

Optional Accessories

- 068** Audible Alarm with Silence Switch
Uses (1) set of Summary contacts
- 21P** DNP3 Communications Protocol
- 21Q** Modbus Communications Protocol
- 19Q** Quadrant System (Refer to Quadrant System guide)*

*La Marche Mfg. Co. does not provide the wires/hardware necessary to connect to the battery at these taps (18 AWG is recommended).

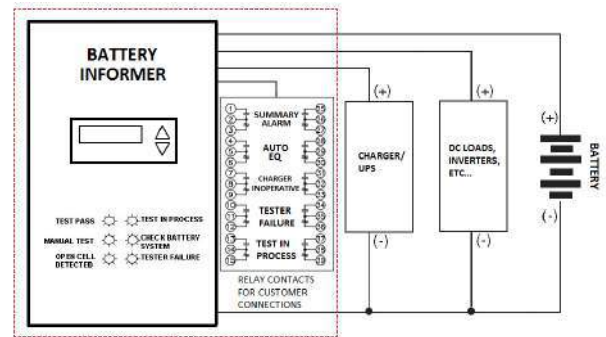

Typical system application diagram



TABLE OF CONTENTS

BATTERY INFORMER SERIES (US PATENTED)

LIVE CIRCUIT BATTERY TESTING
STATIONARY BATTERY INFORMER

Battery Informer (BI) Models

24VDC	Case Size	4B	4B	4B	4B	4B	4	4	4	4	4	4
	Battery Amp Hour Range	25-50	51-100	101-150	151-300	301-400	401-500	501-600	601-700	701-800	801-900	901-1000
	Continuous Load 0-100A	BI-100-24V-50	BI-100-24V-100	BI-100-24V-150	BI-100-24V-300	BI-100-24V-400	BI-100-24V-500	N/A	N/A	N/A	N/A	N/A
	Continuous Load 0-200A	N/A	N/A	N/A	N/A	N/A	N/A	BI-200-24V-600	BI-200-24V-700	BI-200-24V-800	BI-200-24V-900	BI-200-24V-1000
	Continuous Load 0-400A	N/A	N/A	N/A	N/A	N/A	N/A	BI-400-24V-600	BI-400-24V-700	BI-400-24V-800	BI-400-24V-900	BI-400-24V-1000

48VDC	Case Size	4B	4B	4B	4	4	4	4	4	4	4	4
	Battery Amp Hour Range	25-50	51-100	101-150	151-300	301-400	401-500	501-600	601-700	701-800	801-900	901-1000
	Continuous Load 0-100A	BI-100-48V-50	BI-100-48V-100	BI-100-48V-150	BI-100-48V-300	BI-100-48V-400	BI-100-48V-500	N/A	N/A	N/A	N/A	N/A
	Continuous Load 0-200A	N/A	N/A	N/A	N/A	N/A	N/A	BI-200-48V-600	BI-200-48V-700	BI-200-48V-800	BI-200-48V-900	BI-200-48V-1000
	Continuous Load 0-400A	N/A	N/A	N/A	N/A	N/A	N/A	BI-400-48V-600	BI-400-48V-700	BI-400-48V-800	BI-400-48V-900	BI-400-48V-1000

130VDC	Case Size	4B	4B	4	4	4	4	9	9	9	9	9
	Battery Amp Hour Range	25-50	51-100	101-150	151-300	301-400	401-500	501-600	601-700	701-800	801-900	901-1000
	Continuous Load 0-100A	BI-100-130V-50	BI-100-130V-100	BI-100-130V-150	BI-100-130V-300	BI-100-130V-400	BI-100-130V-500	N/A	N/A	N/A	N/A	N/A
	Continuous Load 0-200A	N/A	N/A	N/A	N/A	N/A	N/A	BI-200-130V-600	BI-200-130V-700	BI-200-130V-800	BI-200-130V-900	BI-200-130V-1000
	Continuous Load 0-400A	N/A	N/A	N/A	N/A	N/A	N/A	BI-400-130V-600	BI-400-130V-700	BI-400-130V-800	BI-400-130V-900	BI-400-130V-1000

Case Specifications

Case No.	Overall Dimensions			Approximate Unit Shipping Weight		Mounting
	Width	Depth	Height*	lbs	kgs	
	in	in	in			
4B	16.878	15.000	14.050	60	27.3	19/23" RACK, WALL / FLOOR
4	16.878	15.000	25.875	105	47.7	19/23" RACK, WALL / FLOOR
9	20.735	15.000	37.875	180	81.8	23" RACK, WALL / FLOOR

* Including door mounting bracket

Model Number Nomenclature

BI - 100 - 24V - 50 - () - ()

Continuous Load	DC Voltage	Battery Informer ** AMP Hour Rating	Number & Type of Battery Cells ***
100	24V	50	12L
200	48V	100	23L/24L
400	130V	150	58L/60L
		300	18-20 N
		400	35-40 N
		500	90-95 N
		600	
		700	***Consult factory for other types of batteries
		800	
		900	
		1000	L - Lead acid N - Nickel Cadmium

**Consult factory for Battery Amp Hour Ranges over 1000A

Ordering Information

When ordering, please specify:

- La Marche Model Number
BI (Battery Informer)
- Continuous Load (Load current draw under normal operations)
- DC Voltage
- Battery Amp Hour Rating
- Number & Type of Battery Cells
- Optional Accessories



Model Shown: ARBS-1600-50

ARBS Automatic Redundant Battery Selector

The La Marche ARBS is a solid state device that controls redundant power in engine starting switchgear applications. Our product is designed with high powered diodes to select the higher voltage of the two isolated DC power sources. The ARBS selects power from the best available battery while isolating the alternate battery bank. The special heat sink diode assembly is manufactured to handle high output requirements with safety margin to spare.

This Automatic Redundant Battery Selector is also known in the market as Best Battery Selector, Diode Isolator, and Automatic Battery Selector.

The diodes in the ARBS allows the current to flow from the DC power source to the load. The ARBS is sized based on the maximum load inrush current

Model Number	Nominal Voltage	Rated DC Inrush Current per NFPA 110	Continuous DC Rated Current	Dimensions W x D x H	Case No.	Mounting
ARBS-500-50	(max: 300VDC)	500A	50A @ +50C	12.8" x 10" x 17.12" 326 x 254 x 435mm	2	Wall/Floor
ARBS-500-100	(max: 300VDC)	500A	100A @ +50C	12.8" x 10" x 17.12" 326 x 254 x 435mm	2	Wall/Floor
ARBS-500-200	(max: 300VDC)	500A	200A @ +50C	CF	7	CF
ARBS-1000-50	(max: 300VDC)	1000A	50A @ +50C	12.8" x 10" x 17.12" 326 x 254 x 435mm	2	Wall/Floor
ARBS-1000-100	(max: 300VDC)	1000A	100A @ +50C	12.8" x 10" x 17.12" 326 x 254 x 435mm	2	Wall/Floor
ARBS-1000-200	(max: 300VDC)	1000A	200A @ +50C	CF	7	CF
ARBS-1600-50	(max: 300VDC)	1600A	50A @ +50C	14.25"x 10.62" x 19.87" 362 x 270 x 505mm	7	Wall/Floor
ARBS-2600-85	(max: 300VDC)	2600A	85A @ +50C	25.58" x 13.93" x 28" 650 x 354 x 711mm	4	Wall/Floor/Rack
ARBS-3000-85	(max: 300VDC)	3000A	85A @ +50C	25.58" x 13.93" x 28" 650 x 354 x 711mm	4	Wall/Floor/Rack
ARBS-4800-150	(max: 300VDC)	4800A	150 @ +50C	25.58" x 13.93" x 28" 650 x 354 x 711mm	4	Wall/Floor/Rack

Standard Features

- Fully Automatic
- Convection Cooled
- Isolation From One Battery to Another
- Diodes Designed to Carry 100% of the Starter/Load
- Surge Protection
- Two Diodes, Common Cathode
- Finish - ANSI - 61 gray paint
- 1 Year Warranty

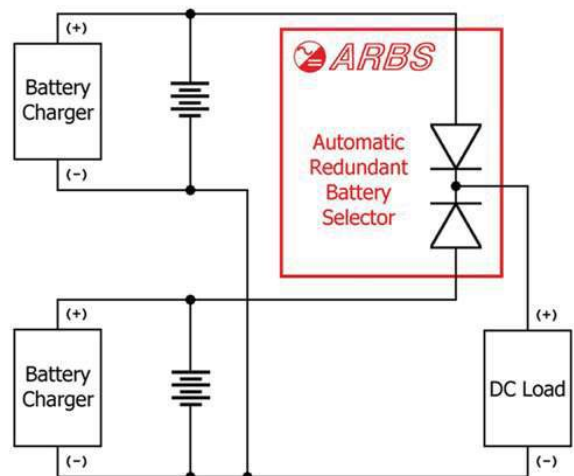
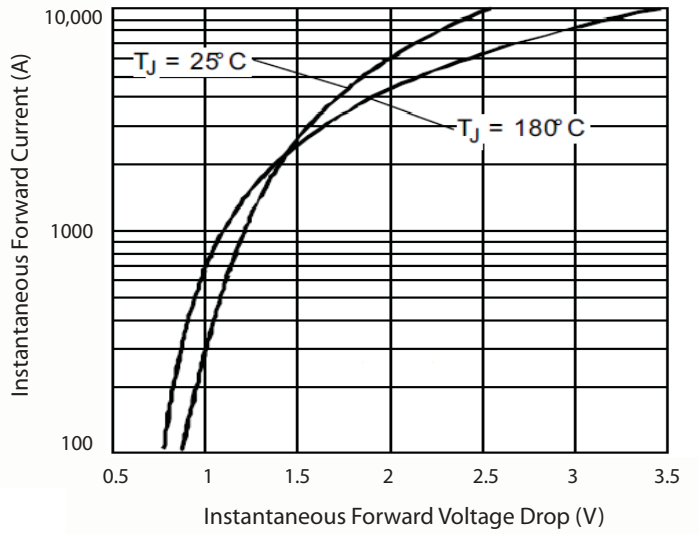
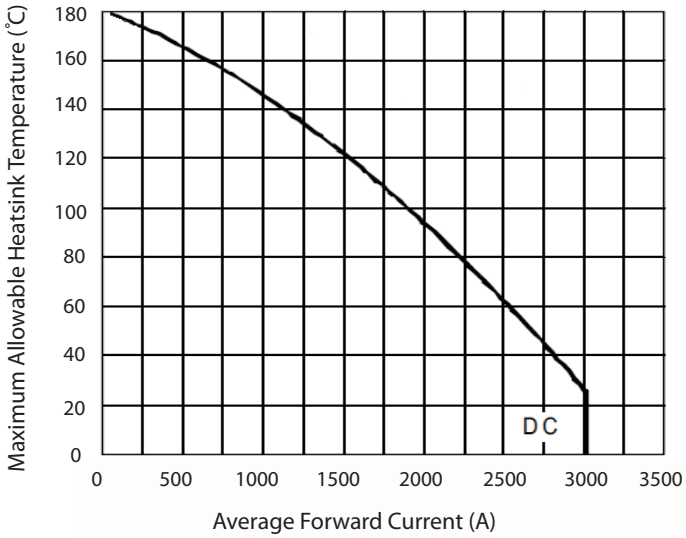
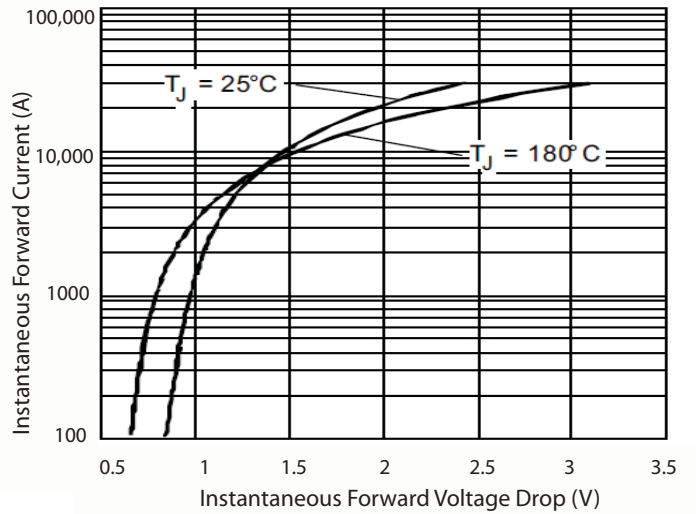
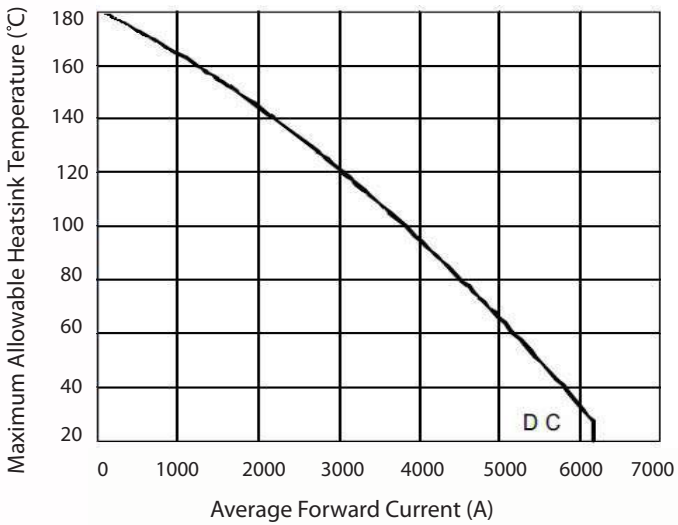

TABLE OF CONTENTS

ARBS-1600



ARBS-3000



ARBS-4800

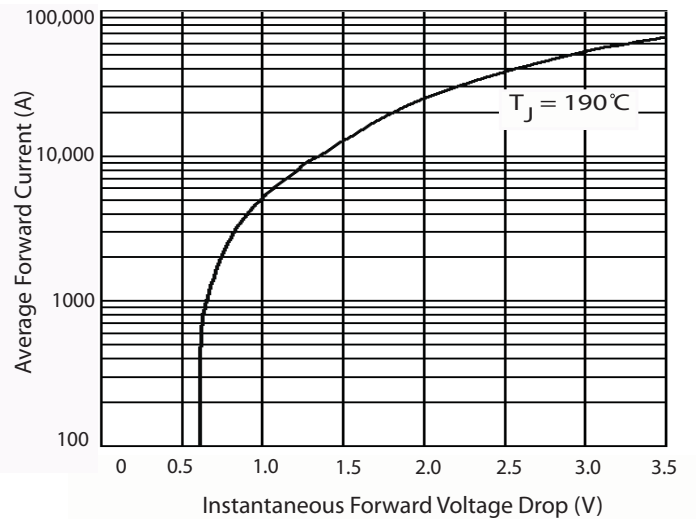
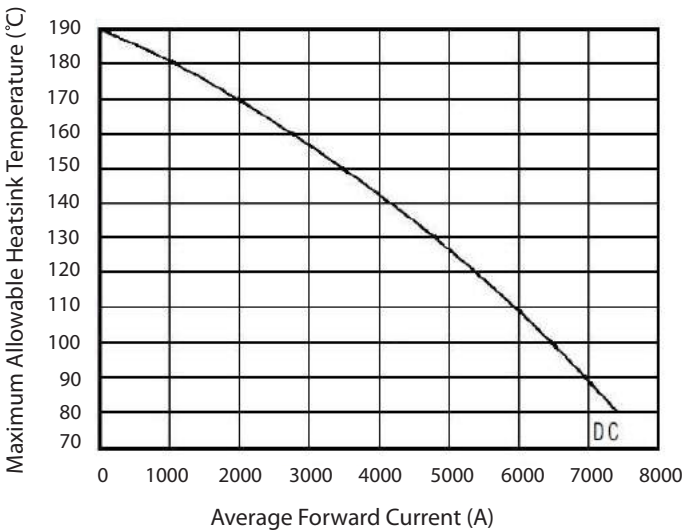

Battery Distribution Center



La Marche BDC provides quick, easy and flexible means of distributing battery charging current to multiple batteries simultaneously. Ideal for maintenance facilities such as commuter bus and trains, that requires heavy-duty rugged construction throughout to handle extreme conditions.

The BDC can be configured for 2 4 or 6 batteries and are available for future expansion. The internal common bus is rated at 200A maximum continuous current. The standard configuration includes breaker on/off switch and a DC ammeter. It is equipped with a pilot LED and reverse polarity indicator with audible alarm. Heavy-duty insulated covers for battery clips are included to provide additional safety.

Standard Features

- 3 Ft Battery Cables With Clips
- 200 Amp Capacity
- DC Pilot Light For Each Battery Position
- Reverse Battery Indicator With Audible Alarm
- On / Off Breaker For Each Battery Position

Model Number	Amps	Voltage	# Battery Cable Sets	Cable Length (ft)	Dimensions	Weight (lbs)
BDC-200-12V-2-3FT	200	12V	2	3	18"W x 7"D x 12"H	35
BDC-200-12V-4-3FT	200	12V	4	3	36"W x 7"D x 12"H	55
BDC-200-12V-6-3FT	200	12V	6	3	54"W x 7"D x 12"H	75



Accessory Package



46 Series (LCD)



16 Series (LED)

The Digital C.A.P. (Combined Accessory Package) Systems feature a microprocessor-based design that incorporates the most popular alarms combined with a Multi-Mode Equalize Timer and a Digital Display in one convenient factory installed package.

The Alarm relay contacts and LED indicators allow the user to report faulty conditions remotely and locally. Alarm conditions are reported via Form "C" contacts to alert the operator of a faulty condition of the DC Power System to take corrective actions. Individual Alarm LEDs and the Digital Display are provided for local supervision.

You are not limited to a one size fits all – several Digital C.A.P. System configurations are offered to meet your specific needs. Whether Ground Detection, Low Voltage Battery Disconnect, Low Voltage Load Disconnect or an Audible Alarm is required, La Marche offers a wide variety of solutions for every application.

Completely user friendly, the Digital C.A.P. System alarm settings can be adjusted and calibrated in the field without requiring of special tools or equipment. Best of all, adjustments can be made when the battery is on-line without affecting the load, thus reducing costly downtime.

Standard Features

- Display for DC Voltage, DC Current & Alarms
 - Float & Equalize Mode
 - Alarm LED Indicator
 - AC Power Failure Alarm
 - Low DC Current Alarm
 - Low DC Voltage Alarm(s)
 - High DC Voltage Alarm
 - High DC Voltage Shutdown Alarm
 - Positive & Negative Ground Alarm
 - Summary Alarm Adjustment Time Delay (0-225 Sec.)
 - Form "C" Contacts
 - Multi - Mode Equalize Timer; Adjustable from 1 - 144 hrs with five selectable modes: Standard, 7 - day, 14 - day, 30 - day and Equalize after Low DC Voltage
- All Alarm Contacts are Rated for 0.5A @120VAC, 2A @ 30VDC and 0.25a @ 125VDC

Optional Accessories

- Discrete LEDs Available for 46 Series

TABLE OF CONTENTS

Features	16E	---	16J	---	16P	---	16T	---	---	---
	46E	46G	46J	46L	46P	46Q	46T	46U	46A	46B
	Available on Charger Models									
	A12B A46	A12B	A12B A46 A97	A12B			A12B A97	A12B		
Display for: DC Voltage, DC Current (Amps), Timer Mode, Equalize Time Remaining (hrs)	✓	✓	✓	✓	✓	✓	✓	✓	---	---
Multi-Mode Digital Equalize Timer; adjustable from 1-144 hrs with five selectable modes: Standard, 7-day, 14-day, 30-day, Equalize after Low DC Voltage	✓	✓	✓	✓	✓	✓	✓	✓	---	---
Equalize Light	✓	✓	✓	✓	✓	✓	✓	✓	---	---
Float Light	✓	✓	✓	✓	✓	✓	✓	✓	---	---
AC Power Failure Relay with (2) sets Form "C" (De-energizes during alarm condition)	✓	✓	✓	✓	✓	✓	✓	✓	---	---
Low DC Current Alarm (2) sets Form "C" (De-energizes during alarm condition)	✓	✓	✓	✓	✓	✓	✓	✓	---	---
Low DC Voltage 1 Alarm (2) sets Form "C" (De-energizes during alarm condition)	✓	✓	✓	✓	✓	✓	✓	✓	---	---
Low DC Voltage 2 Alarm (2) sets Form "C" (De-energizes during alarm condition)	✓	---	---	---	✓	---	---	---	---	---
Low DC Voltage 2 Alarm (1) set Form "C" (De-energizes during alarm condition) Utilized for Low Voltage Battery Disconnect	---	✓	---	---	---	---	---	✓	---	---
Low DC Voltage 2 Alarm (1) set Form "C" (De-energizes during alarm condition) Utilized for Low Voltage Load Disconnect	---	---	---	✓	---	✓	---	---	---	---
Low DC Voltage 2 Alarm (No contacts)	---	---	✓	---	---	---	✓	---	---	---
High DC Voltage Alarm (2) sets Form "C" (Energizes during alarm condition)	✓	✓	✓	✓	✓	✓	✓	✓	---	---
High DC Voltage Shutdown Alarm (1) set Form "C" (Energizes during alarm condition)	✓	✓	✓	✓	✓	✓	✓	✓	---	---
Positive Ground Alarm Light (Green LED) with (1) set Form "C" (Energizes during alarm condition)	---	---	✓	---	---	✓	✓	✓	---	---
Negative Ground Alarm Light (Green LED) with (1) set Form "C" (Energizes during alarm condition)	---	---	✓	---	---	✓	✓	✓	---	---
Summary Alarm with (2) sets Form "C" includes: AC Power Failure, Low DC Current (can be de-selected), Low DC Voltage, Low DC Voltage 2, High DC Voltage, High DC Voltage Shutdown. Adds Positive & Negative Ground on 46J, 46Q, & 46U. (De-energizes during alarm condition)	✓	✓	✓	✓	---	✓	---	✓	---	---
Summary Alarm with (1) set Form "C" includes: AC Power Failure, Low DC Current (can be de-selected), Low DC Voltage, Low DC Voltage 2, High DC Voltage, High DC Voltage Shutdown. Adds Positive & Negative Ground 46T. (De-energizes during alarm condition)	---	---	---	---	✓	---	✓	---	---	---
Audible Alarm with Silence Switch	---	---	---	---	✓	---	✓	---	---	---
LED Indicator Board w/o Ground (Available for 46E, 46P, 46G or 46L)	---	---	---	---	---	---	---	---	---	✓
LED Indicator Board w/ Ground (Available for 46J, 46U, 46Q or 46T)	---	---	---	---	---	---	---	---	✓	---

DIGITAL C.A.P. DESCRIPTIONS

C.A.P. Systems common features: Selectable Display, Multi- Mode Equalize Timer, Equalize light, Float light, AC Power Failure Relay w/ (2) sets Form "C" (except 16Q/46Q), Low DC Current Alarm w/ (2)sets From "C" & Adjustable Time Delay (0-255 sec) (Except Ground Detection Alarms)

16E or 46E (For La Marche Charger models A12B & A46 Only): Low DC Voltage 2 Alarms w/ (2) sets From "C" , High DC Voltage Shutdown Alarms w/(1) set From "C", Summary Alarm (all alarms listed above) w/ (2) sets From "C" (Low DC Current can be de-selected).

46G (For La Marche Charger model A12B only): Low DC Voltage 2 Alarm utilized for Low Voltage Battery Disconnect w/ (1) set From "C", High DC Voltage Alarm w/(2) sets Form "C", High DC Voltage Shutdown Alarm w/ (1) set From "C", Summary Alarm (all alarms listed above) w/ (2) sets From "C" (Low DC Current can be de-selected).

16J or 46J (For La Marche Charger model A12B, A46 & A97 only): Low DC Voltage Alarm (no contacts), High DC Voltage Alarm w/ (2) sets From "C", High DC Voltage Shutdown Alarm w/ (1) set From "C", Positive Ground Alarm Light w/ (1) set of Form "C", Negative Ground Alarm Light w/ (1) set Form "C", Summary Alarm (all alarms listed above) w/ (2) sets Form "C" (Low DC Current can be de-selected).

46L (For La Marche Charger model A12B only): Low DC Voltage 2 Alarm utilize for Low Voltage load Disconnect w/ 1 set From "C", High DC Voltage Alarm w/ (2) sets Form "C", High DC Voltage Shutdown Alarm w/ 1 set Form "C", Summary Alarm (all alarms listed above) w/ (2) sets Form "C" (low DC Current can be de-selected).

16P or 46P (For La Marche Charger model A12B only): Low DC Voltage 2 Alarm w/ (2) sets Form "C", High DC Voltage Alarm w/ (2) sets Form "C", High DC Voltage Shutdown Alarm w/ (1) set Form "C", Summary Alarm (all alarms listed above) w/ (1) set Form "C" (Low DC Current can be de-selected).

46Q (For La Marche Charger model A12B only): Low DC Voltage 2 Alarm w/ (1) set of form "C" contacts utilized for Low Voltage Load Disconnect, High DC Voltage Alarm w/ (2) sets Form "C" High DC Voltage Shutdown Alarm w/ (1)set Form "C", Positive Ground Alarm w/ (1) set Form "C", Negative Ground Alarm Light w/ (1) set Form "C", Summary Alarm (all alarms listed above) w/ (2) sets Form (Low DC Current can be de-selected).

16T or 46T (For La Marche Charger model A12B & A97 only): Low DC Voltage 2 Alarm Light (no contacts), High DC Voltage Alarm w/ (2)sets Form "C", High DC Voltage Shutdown Alarm w/ (1) set Form "C", Positive Ground Alarm w/ (1) set of Form "C", Negative Ground Alarm w/ (1) set Form "C", Summary Alarm (all alarms listed above) w/ (1) set Form "C" (Low DC Current can be de-selected), Audible Alarm w/ Silence Switch.

46U (For La Marche Charger model A12B only): Low DC Voltage 2 Alarm utilized for Low Voltage Battery Disconnect w/ (1) set Form "C", High DC Voltage Alarm w/ (2) sets Form "C", High DC Voltage Shutdown Alarm w/ (1) set Form "C", Positive Ground Alarm Light w/ (1) set of Form , Negative Ground Alarm Light w/ (1) set Form "C", Summary Alarm (all alarms listed above) w/ 2 sets Form "C" (Low DC Current can be de-selected).

46A (For La Marche Charger model A12B only): LED Indicator Board w/o Ground (Available for 46E, 46P, 46G or 46L)

46B (For La Marche Charger model A12B only): LED Indicator Board w/ Ground (Available for 46J, 46U, 46Q or 46T)

**Floor Stands, Drip Shields & Mounting Kits
Enclosure Accessories**

Model Number Nomenclature	
Model Number	Model Number Suffix
()	()

When Ordering Please Specify:
Model Number
Model Number Suffix

Model Number	
P3	Floor Stands
S4C1	Dripshields
SP3K-FLR/R1	Floor Mounting Kit
SP3K-WR1	Wall Mounting Kit

Floor Stands		
Model Number	For Case No.	Height (Inches) Floor To Case
P3-3-L05A	3	26.00
P3-4-L01A	4	30.00
P3-6-L07A	6	18.00
P3-70/72-L01A	70 & 72	18.00
P3-8A-L04A	8A	40.00
P3-9-L01A	9	30.00

Drip Shield Kits				
Model Number	For Case No.	Length (inches)	Width (inches)	Height (inches)
S4C1-1-2	1	12.75	9.38	1.88
S4C1-2-1	2	15.38	11.69	1.88
S4C1-3-1	3	17.69	11.44	1.88
S4C1-05-1	05	9.50	7.75	1.06
S4C1-6-2	6	28.00	14.88	2.56
S4C1-7-1	7	16.63	13.25	1.88
S4C1-72-1	70 & 72	Consult Factory		

Floor Mounting Kit	
Model Number	Description
SP3K-FLR/R1	For Case No. 4D, 9D, 9E, 33 & 39

Wall Mounting Kit	
Model Number	Description
SP3K-WR1	For Case No. 4D, 9D, 33 & 39

Consult Factory For Further Details

P25-DSENCN_ACCESSORIES-1
ECN 16625
01-05



COMMUNICATION BOARD

The La Marche communication board allows users to monitor selected La Marche models over a serial connection. La Marche battery chargers can be equipped with serial RS-485, RS-232 or TCP/IP ports for data communication over Modbus, DNP3.0 and LAN. The TCP/IP port eliminates the need for a serial to TCP/IP converter to connect to the LAN. These protocols allow easy communication within all types of network architectures. The communication protocols are being used between Intelligent Electronic Devices (IEDs) and Remote Terminal Units (RTUs) in substations to monitor and control.

DNP3.0 and Modbus permits a device to report digital inputs, counter inputs and analog inputs. DNP3.0 supports reporting mode, where remote devices can report field events without being polled by the master station. This protocol supports multiple methods of reading inputs individually or as a group. All three protocols query the charger for the current status.

The communication board is designed for the utility industry and is immune to electrical noise. The RS-232 is limited to a maximum cable length of 50 feet and RS-485 can have cable lengths up to 4,000 feet. It provides an efficient means of gathering small quantities of data from the battery charger for the SCADA system.

The RS-232 and RS-485 connections are galvanically isolated. The ethernet port is also isolated per the IEEE specs. The La Marche communication option has wide market acceptance and is implemented by major utility providers.

Standard Features

- DNP3.0 or Modbus over an:
 - RS-232, RS-485 or TCP/IP
- Analog Inputs and Setpoints
 - DC Voltage
 - DC Current
 - Equalize Time Remaining
 - Equalize Timer Mode
 - Low DC Voltage
 - High DC Voltage
 - High DC Voltage Shutdown
- Alarms
 - AC Failure or Blown DC Protection
 - Low DC Voltage
 - High DC Voltage
 - High DC Voltage Shutdown
 - Low DC Current
 - Positive Ground
 - Negative Ground
 - Selectable Summary
- Control Relay Output Blocks/Coils
 - Float/Equalize
 - Low Current in Summary Alarm
 - AC Failure in Summary Alarm
 - Ground Detection in Summary Alarm
- Fully Isolated RS-232 & RS-485 Connectors

Available on the following models

A12B, A36D, A75DE & TPSD

Option Codes:

- 21P - DNP3.0
- 21Q - Modbus

Specifications subject to change without notice.

P25-DSDNP3-1

ECN: 18508

11/09

La Marche Manufacturing Company
 106 Bradrock Drive, Des Plaines, IL 60018-1967
 Tel: 1-847-299-1188 Toll Free Fax: 1-888-232-9562
 sales@lamarchemfg.com www.lamarchemfg.com

Made in USA



La MARCHÉ®

ISO 9001:2000 CERTIFIED

RELAY RACK

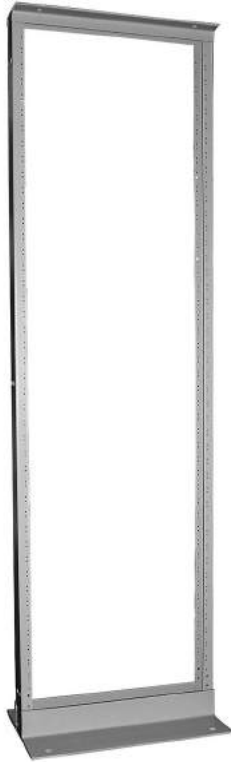

- ### Standard Features
- Relay Racks constructed from 11 gauge steel
 - ANSI-61 gray paint finish
 - The 3 inch vertical channels are drilled and tapped on the front and rear for 12-24 NC hardware
 - Welded construction
 - 19 or 23 inch wide configuration
 - Holes in sides of rack for joining racks
 - 1.75 inch mounting hole pattern
- ### Options
- (Consult factory for further details)*
- Seismic Relay Rack
 - Aluminum Relay Rack
 - Steel, Bolted Relay Rack
 - Cable Stay

RELAY RACK

La Marche Relay Racks can be used for mounting Rectifiers, Batteries and other related power system equipment.

La Marche offers an array of Relay Rack heights in both 19 and 23 inch widths. See our web site for a detailed drawing of the relay rack.

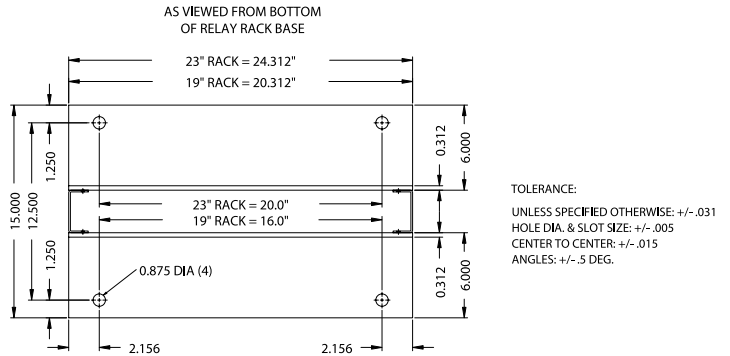

Chart for 19" Relay Rack

Model Number	Height (feet)	Rack Width* (inches)	Rack Units
P3-RR-P110	6.00	20.312	36
P3-RR-P040	7.00	20.312	43
P3-RR-P100	7.50	20.312	47
P3-RR-P120	8.00	20.312	50
P3-RR-P080	9.00	20.312	57

*Center to center is 18.312 inches.

Chart for 23" Relay Rack

Model Number	Height (feet)	Rack Width** (inches)	Rack Units
P3-RR-P020	6.00	24.312	36
P3-RR-P060	7.00	24.312	43
P3-RR-P180	7.50	24.312	47
P3-RR-P050	8.00	24.312	50
P3-RR-P070	9.00	24.312	57

**Center to center is 22.312 inches.

Specifications are subject to change without notice.

P25-DSP3-RR-RACKS-1
ECN 16713
03-05

La Marche Manufacturing Company
106 Bradrock Drive, Des Plaines, IL 60018-1967
Tel: 1-847-299-1188 Toll Free Fax: 1-888-232-9562
sales@lamarchemfg.com www.lamarchemfg.com

Made in USA



LaMARCHE®

ISO 9001 CERTIFIED



CDPD Center mounted on 23" rack with optional Digital Status Alarm package

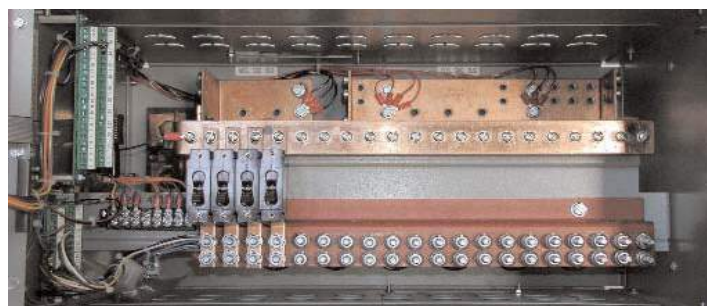

Inside View of CDPD Center shown with optional Breakers

COMPACT DISTRIBUTION CENTER - ALL IN ONE DESIGN

The LaMarche CDPD (Combination Distribution Panel) center is designed for use with all LaMarche rectifier systems built on a standard 23" rack frame. This compact unit's standard features includes Ground & Charge busbars and provisions for up to (20) Load Breakers. With its optional Low Voltage Disconnect & Digital Status Alarm packages, the CDPD offers a compact solution utilizing only half of the rack spaces that would be required with standard discrete panel assemblies.

The CDPD center is accessible from the front, allowing the wiring of Load Breakers without requiring rear access. Threaded inserts provide quick and simple mounting of breakers in the field. The CDPD center provides versatile wiring access to the Battery and Load Termination points via the top, rear and bottom. A designation label is provided to identify Load and Breaker positions/ratings.

The CDPD center can accommodate up to (20) 1-pole Breakers for load distribution. Each breaker can be rated up to 125 amps, with a maximum total distribution rating of 200 & 400 amps of the respective CDPD models. Breakers rated from 10 to 60A utilizes (1) position, 70 to 100A utilizes (2) positions and the 125A

Standard Features

- 24VDC & 48VDC Positive or Negative Return versions
- 200A & 400A rated models
- Compact Design measuring 23"W (for relay rack mounting) X 15.5"D x 12.25"H (7 ru's). Consult factory for 19" rack mount availability.
- Front Accessibility with removable Top and Bottom panels
- 20-Position Single-Pole Load Breakers (0-125A) w/ Breaker Tripped LED and Form "C" contact.
- Ground/Charge Busbars
Accommodates Single or Two-Hole Lugs
Threaded inserts for ease of installation
- Ground Bus Termination Provisions
Qty (20) Load Returns for Two-Hole Lugs 1/2" centers and 1/4-20 hardware
Qty (3) Battery Returns for Two-Hole Lugs 1" centers and 5/16-18 hardware
- Charge Bus Termination Provisions
Qty (3) Battery Connections for Two-Hole Lugs 1" centers and 5/16-18 hardware

Optional Features

- Low Voltage Load Disconnect Package is Field Adjustable and includes: Fused Disconnect Contactor, Calibration Voltage Adjustment LED, Pickup Adjustment LED, Dropout Voltage Adjustment LED and Connected LED. With (2) Form "C" LVLD Alarm contacts
- Digital Status Alarm Package includes a Digital Volt/Amp Meter LED Display, a Multi-Mode Electronic Equalize Timer and Form "C" Alarm contacts for Breakers Tripped, Low Voltage, Low Voltage 2, Low Current, High Voltage and Summary Alarm. An Audible Alarm w/ Silence Switch is provided for the Summary Alarm.

breaker utilizes (4) positions of the (20) available. 200 & 400 amps Positive & Negative busbars for terminating Batteries and Load Return leads are provided as standard. The busbars can accommodate Single and/or Two-Hole Terminal Lugs.

An optional Low Voltage Disconnect circuit is available to disconnect the load from the system thus protecting the Battery bank from an over discharge. A Calibration circuit is provided to set the alarm points to the desired thresholds allowing adjustments to be made while the system is energized without affecting the load. The optional Digital Status Alarm package features a Digital Volt/Amp Meter LED Display with form "C" Alarm contacts as well as a Multi-Mode Electronic Equalize Timer to provide an equalize charge to the Battery bank when necessary.

LaMarche Manufacturing Company

106 Bradrock Drive, Des Plaines, IL 60018-1967
Tel: 847-299-1188 Toll Free Fax: 1-888-232-9562
sales@lamarchemfg.com www.lamarchemfg.com

CDPD Centers

Model Number	DC Voltage	Maximum Bus Rating	Low Voltage Disconnect	Digital Alarm System
CDPD400-24V-23-2	24	400	---	---
CDPD400-48V-23-2	48	400	---	---
CDPD200-24V-23-1	24	200	included	---
CDPD400-24V-23-1	24	400	included	---
CDPD200-48V-23-1	48	200	included	---
CDPD400-48V-23-1	48	400	included	---
CDPD200-24V-23-22	24	200	---	included
CDPD400-24V-23-22	24	400	---	included
CDPD200-48V-23-22	48	200	---	included
CDPD400-48V-23-22	48	400	---	included
CDPD200-24V-23-23	24	200	included	included
CDPD400-24V-23-23	24	400	included	included
CDPD200-48V-23-23	48	200	included	included
CDPD400-48V-23-23	48	400	included	included

- All CDPD centers are for 23" rack mounting. Overall dimensions are 23"Wx15.5"Dx12.25"H. Approximate weight of CDPD centers is 50 lbs.
- Positive Ground System is standard configuration. Part number changes as follow for Negative Ground Systems: CDPD400-24VN-23-2.
- Standard CDPD centers have (20) breaker positions for load distribution. Optional Breaker Kits are not included in CDPD (see adjacent chart for optional available breaker kits).
- Straight lugs are used if termination is from the top or bottom. 90° Turn Lugs are required to terminate through the back of the CDPD center. (see adjacent chart for optional available Compression type Lugs).

Optional U.L. Recognized Breaker Kits

Kit Number	Ampere Rating	Number of required breaker positions
SP4K-CDPD-10B1	10A	1
SP4K-CDPD-20B1	20A	1
SP4K-CDPD-30B1	30A	1
SP4K-CDPD-40B1	40A	1
SP4K-CDPD-50B1	50A	1
SP4K-CDPD-60B1	60A	1
SP4K-CDPD-70B1	70A	2
SP4K-CDPD-80B1	80A	2
SP4K-CDPD-90B1	90A	2
SP4K-CDPD-100B1	100A	2
SP4K-CDPD-125B1	125A	4

Optional Two-Hole Lug Kits

Lug Kit Number	Straight Lug		90° Lug	
	Qty	Size	Qty	Size
S4B-CDP/D-2	1	#6 AWG	1	#6 AWG
S4B-CDP/D-6	20	#6 AWG	20	#6 AWG
S4B-CDP/D-6S	40	#6 AWG	---	---

Optional Two-Hole Individual Lugs

Lug Number	Lug Type	Size
P7LUG-60	Straight Lug	#6 AWG
P7LUG-58	90° Lug	#6 AWG

Detailed Mounting Dimensions

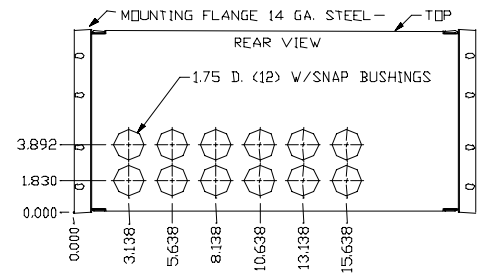
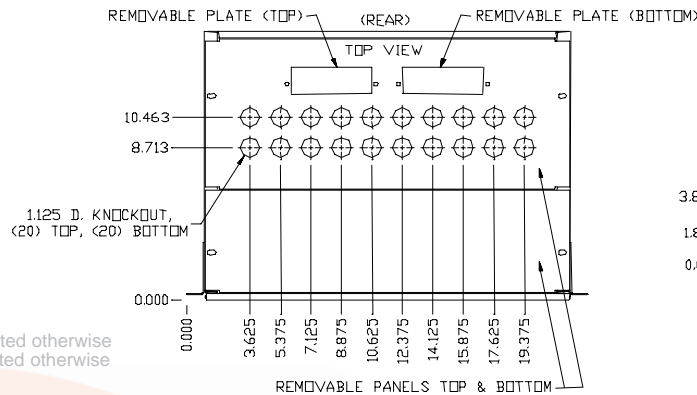

Notes:
 All Dimensions given in inches
 Material: 16GA. Steel unless noted otherwise
 Finish: ANSI 61 Gray unless noted otherwise

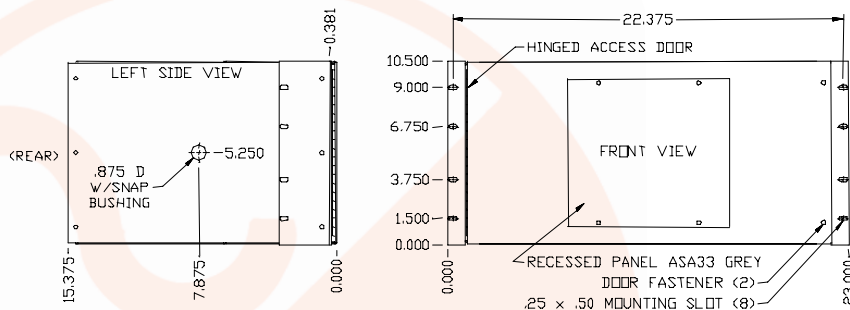

Specifications subject to change without notice

P25-DSKDPD-1
 ECN 14854
 09-01



106 Bradrock Drive, Des Plaines, IL 60018-1967
 Tel: 847-299-1188 Toll Free Fax: 1-888-232-9562
 sales@lamarchemfg.com www.lamarchemfg.com

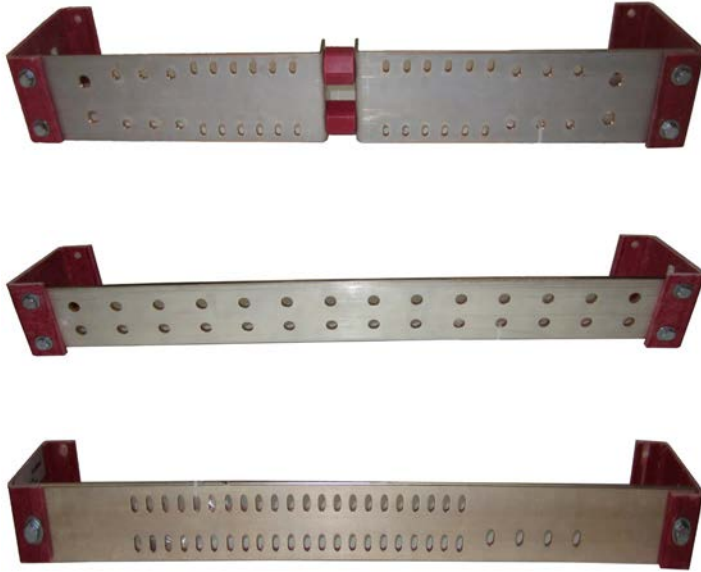

Terminal Buses & Lug Kits

La Marche Termination Bus Bars provide a convenient means of system ground or lead connections. These bus bars have insulated standoffs to electrically isolate them from the rack. Each bar is made of solid copper sized to handle its rated current and is available in either 19 or 23 inch relay rack mount. The copper bars are silver flash plated to prevent corrosion. Termination bus bars can be provided with various quantities and sizes of solderless lugs. All termination bars greater than 200 amps are available for NEMA 2-hole lugs-. Please consult our factory for details. Model GCB Series Split Bus Termination is standard for all rack systems unless otherwise specified.

Lug Kit Descriptions

Lug Kit Number	Quantity of Lugs Per Kit			
	P969-8	P969-7	P969-9	P969-1
S4B-1	20	7	---	---
S4B-2	---	10	---	---
S4B-3	20	---	4	---
S4B-4	20	5	4	---
S4B-5	---	10	4	---
S4B-6	20	---	4	2
S4B-7	---	10	4	2
S4B-8	10	5	4	2
S4B-9	22	---	4	---

Solderless Mechanical Lugs

Model Number	Description
P7LUG-P969-1	#4/0 - 600 MCM
P7LUG-P969-9	#6 - 300 MCM
P7LUG-P969-7	#14 - #2/0 GA
P7LUG-P969-4	#14 - #1/0 GA
P7LUG-P969-3	#14 - #2 GA
P7LUG-P969-8	#14 - #4 GA

Model Number Nomenclature

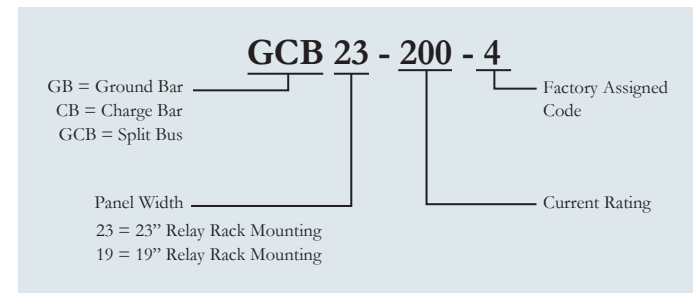



Termination Buses and Lug Kits Specifications

Model Number	Rack Units	Current Rating	Rack Mounting (in.)	Approx. Weight	
				lbs	kgs
GCB19-200	3	200	19	4	1.8
GCB19-450-61	3	450	19	8	3.6
GCB19-600	3	600	19	12	5.4
GCB23-200-4	3	200	23	4	1.8
GCB23-450-58	3	450	23	8	3.6
GCB23-600-3	3	600	23	12	5.4
GCB23-900-60	3	900	23	16	7.2

COMBINATION GROUND/CHARGE BARS

Model GCB19-200:
 Ø 0.281 X 0.375 (X8)
 ON 0.125 INCH THICK COPPER BUS BAR
LUG MODEL: P7LUG-P969-9 (#6 - 300MCM)
 OR SMALLER
 Ø 0.219 X 0.375 SLOT (X32)
 ON 0.125 INCH THICK COPPER BUS BAR
LUG MODEL: P7LUG-P969-7 (#14 - #2/0 GA)
 OR SMALLER

Model GCB19-450-61:
 Ø 0.281 X 0.375 (X8)
 ON 0.250 INCH THICK COPPER BUS BAR
LUG MODEL: P7LUG-P969-9 (#6 - 300MCM)
 OR SMALLER
 Ø 0.219 X 0.375 SLOT (X32)
 ON 0.250 INCH THICK COPPER BUS BAR
LUG MODEL: P7LUG-P969-7 (#14 - #2/0 GA)
 OR SMALLER

Model GCB19-600:
 Ø 0.281 X 0.375 (X8)
 ON 0.250 INCH THICK COPPER BUS BAR
LUG MODEL: P7LUG-P969-9 (#6 - 300MCM)
 OR SMALLER
 Ø 0.219 X 0.375 SLOT (X32)
 ON 0.250 INCH THICK COPPER BUS BAR
LUG MODEL: P7LUG-P969-7 (#14 - #2/0 GA)
 OR SMALLER

Model GCB23-200-4:
 Ø 0.281 X 0.375 SLOT (X10)
 ON 0.125 INCH THICK COPPER BUS BAR
LUG MODEL: P7LUG-P969-9 (#6 - 300MCM)
 OR SMALLER
 Ø 0.219 X 0.375 SLOT (X44)
 ON 0.125 INCH THICK COPPER BUS BAR
LUG MODEL: P7LUG-P969-3 (#14 - #2 GA)
 OR SMALLER

Model GCB23-450-58:
 Ø 0.406 HOLE (X4)
 ON 0.125 INCH THICK COPPER BUS BAR
LUG MODEL: P7LUG-P969-1 (#4/0 - 600MCM)
 OR SMALLER
 Ø .281 HOLE (X12)
 ON 0.125 INCH THICK COPPER BUS BAR
LUG MODEL: P7LUG-P969-9 (#6 - 300MCM)
 OR SMALLER
 Ø .219 X .375 (X24)
 ON 0.125 INCH THICK COPPER BUS BAR
LUG MODEL: P7LUG-P969-9 (#6 - 300MCM)
 OR SMALLER

Model GCB23-600-3:
 Ø 0.438 HOLE (X24)
 ON 0.250 INCH THICK COPPER BUS BAR
LUG MODEL: P7LUG-P969-1 (#4/0 - 600MCM)
 OR SMALLER
 Ø 0.438 X 0.750 SLOT (X18)
 ON 0.250 INCH THICK COPPER BUS BAR
LUG MODEL: P7LUG-P969-1 (#4/0 - 600MCM)
 OR SMALLER

Model GCB23-900-60:
 Ø 0.531 X 0.875 SLOT (X16)
 ON 0.250 INCH THICK COPPER BUS BAR
LUG MODEL: P7LUG-P969-1 (#4/0 - 600MCM)
 OR SMALLER



GROUND BARS

Model Number	Rack Units	Current Rating	Rack Mounting (in.)	Approx. Weight	
				lbs	kgs
GB19-200	3	200	19	4	1.8

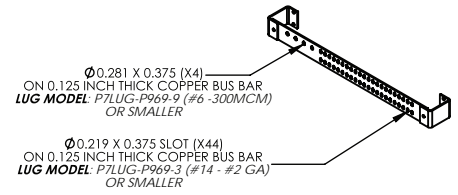

Model Number	Rack Units	Current Rating	Rack Mounting (in.)	Approx. Weight	
				lbs	kgs
GB19-450-62	3	450	19	8	3.6

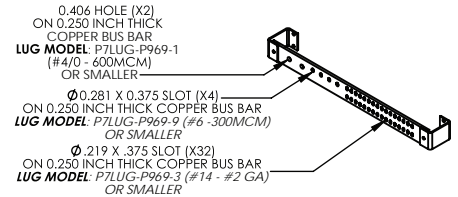

Model Number	Rack Units	Current Rating	Rack Mounting (in.)	Approx. Weight	
				lbs	kgs
GB19-600	3	600	19	12	5.4

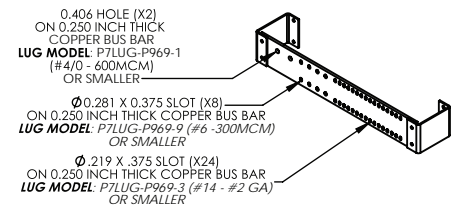

Model Number	Rack Units	Current Rating	Rack Mounting (in.)	Approx. Weight	
				lbs	kgs
GB19-900-63	3	900	19	16	7.2

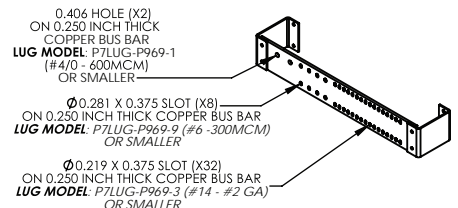

Model Number	Rack Units	Current Rating	Rack Mounting (in.)	Approx. Weight	
				lbs	kgs
GB23-200	3	200	23	4	1.8

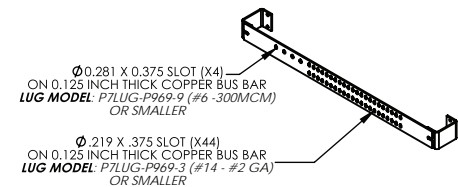

Model Number	Rack Units	Current Rating	Rack Mounting (in.)	Approx. Weight	
				lbs	kgs
GB23-450-64	3	450	23	8	3.6

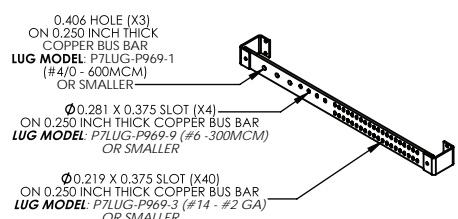

Model Number	Rack Units	Current Rating	Rack Mounting (in.)	Approx. Weight	
				lbs	kgs
GB23-600	3	600	23	12	5.4

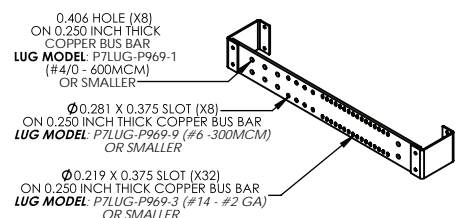

Model Number	Rack Units	Current Rating	Rack Mounting (in.)	Approx. Weight	
				lbs	kgs
GB23-900-57	3	900	23	16	7.2

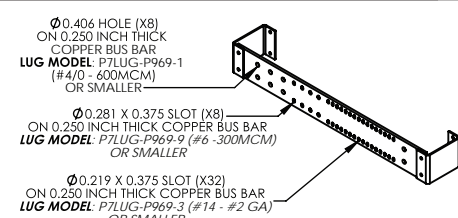



CHARGE BARS

Model Number	Rack Units	Current Rating	Rack Mounting (in.)	Approx. Weight	
				lbs	kgs
CB19-200	3	200	19	4	1.8

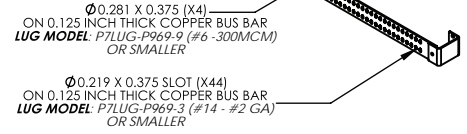

Model Number	Rack Units	Current Rating	Rack Mounting (in.)	Approx. Weight	
				lbs	kgs
CB19-450-29	3	450	19	8	3.6

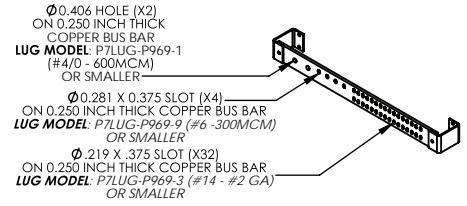

Model Number	Rack Units	Current Rating	Rack Mounting (in.)	Approx. Weight	
				lbs	kgs
CB19-600	3	600	19	12	5.4

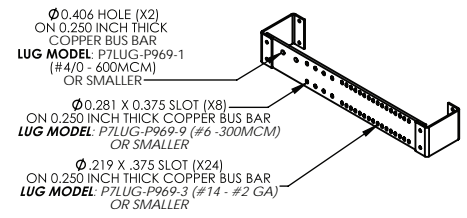

Model Number	Rack Units	Current Rating	Rack Mounting (in.)	Approx. Weight	
				lbs	kgs
CB19-900-30	3	900	19	16	7.2

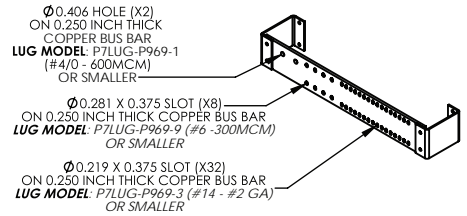

Model Number	Rack Units	Current Rating	Rack Mounting (in.)	Approx. Weight	
				lbs	kgs
CB23-200	3	200	23	4	1.8

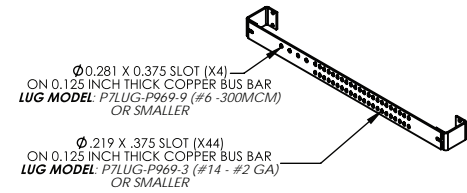

Model Number	Rack Units	Current Rating	Rack Mounting (in.)	Approx. Weight	
				lbs	kgs
CB23-450-28	3	450	23	8	3.6

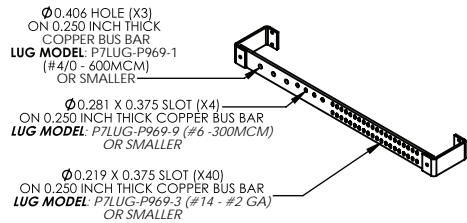

Model Number	Rack Units	Current Rating	Rack Mounting (in.)	Approx. Weight	
				lbs	kgs
CB23-600	3	600	23	12	5.4

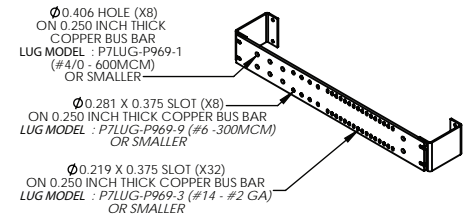

Model Number	Rack Units	Current Rating	Rack Mounting (in.)	Approx. Weight	
				lbs	kgs
CB23-900-27	3	900	23	16	7.2

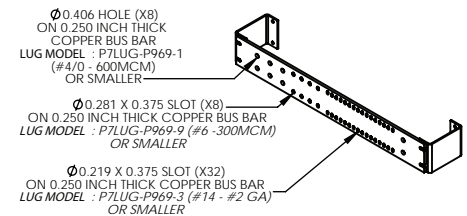



LaMARCHÉ®

ISO 9001 CERTIFIED



MODEL BPK SERIES

Single Pole Circuit Breaker Distribution Panel

Circuit Breaker Distribution Panels are designed to provide protection for multiple load/distribution circuits. The circuit breakers fast trip response assures the panel breaker will trip before the main circuit breaker/fuse so that power will not be interrupted from other critical DC loads if an overload occurs.

BPK Panels utilize UL recognized breakers with an interrupting capacity of 5,000 amps DC at 65 volts.

Connection to the load is made directly to the load side terminal/screw of the breaker. For breakers size up to 70 amps, the terminal is a 10-32 stud with a recommended maximum #6 AWG wire size. For 100 amp breakers, the terminal is a 1/4 - 20 stud with a recommended maximum #4 AWG wire size.

Base panel does not include circuit breakers. For information on available circuit breaker sizes, see list price sheet.

A blank 1.75" high panel (1RU) is recommended below breaker panel for ease of installation.

See reverse side of data sheet for further details about the Model BPK Series Circuit Breaker Distribution Panel.

Specifications are subject to change without notice. Please contact La Marche for latest information.

Product Bulletin: Model BPK Series

Standard Features

- Guard Kit to prevent accidental tripping of breakers.
- Blank fillers furnished for all unused breaker positions.
- Breaker designation label track
- Alarm LED light and form "C" relay alarm contacts. The relay will be activated if any breaker in the panel trips or is shut off.
- Available breaker sizes are 0-100 amps single pole (70-100 amp breakers take two positions).
- Finish – ANSI-61 grey paint

Optional Equipment/Features

- For wire sizes in excess of recommended maximums or for NEMA two hole lug requirements, a separate stand-alone glastic landing strip behind the breaker panel can be provided as a separate optional accessory.
- Right bus connection as viewed from front of breaker panel
- Special paint finishes

Dimensions

- Height 5.25 inches – 3 Rack Units
- Width 19 inches – 18 Breaker Positions
23 inches – 24 Breaker Positions
- Depth 9 inches with Guard Kit
8 inches without Guard Kit

Voltage and Current Ratings

- 12, 24, or 48 volts DC ratings available. Must indicate negative common (return) as part of model number format when applicable. See reverse side of data sheet for model format.
- Total DC continuous current carrying capacity of panel 600 amps.

TYPICAL MODEL NO.	Rack Width	DC Voltage	DC Bus Connection	Alarm Contacts	Negative Common (Return)	Positive Common (Return)	Specific Bill of Material Listing Breakers/Block Off Kits
BPK19-24VL-18RN-3	19"	24V	LEFT	YES	YES	—	3
BPK23-48VL-24R-5	23"	48V	LEFT	YES	—	YES	5

MODEL BPK SERIES

Single Pole Circuit Breaker

Distribution Panel

- NOTES:**
1. BREAKERS MOUNT WITH LARGEST CAPACITY IN POSITION 1
 2. MIXED CAPACITIES WILL BE IN DESCENDING ORDER LEFT TO RIGHT
 3. ADJACENT BREAKER POSITIONS MUST BE SKIPPED WHEN BREAKERS ARE 70A & LARGER
 4. BREAKER BLOCKOFF PLATE (KIT) MUST BE USED IN ALL UNUSED POSITIONS.
 5. TOTAL CAPACITY OF ALL BREAKERS NOT TO EXCEED 600 AMPS
 6. 23" SYSTEM = 24 BKRS. MAX.
 7. 19" SYSTEM = 18 BKRS. MAX.
 8. PARTS ABOVE ARE FOR REFERENCE ONLY. BUILD PANEL PER SPECIFIC PARTS LIST
 9. STANDARD BUS CONNECTION IS TO THE "LEFT"
 10. STANDARD BUS CONNECTION TO "RIGHT" ONLY WHEN SPECIFIED BY ASSY. PARTS LIST
 11. BUS IS INSTALLED WITH CONNECTION TO "RIGHT" ONLY WHEN SPEC. AT-3
 12. STANDARD FINISH IS ANS# #61 GREY PER LMC ENG. SPEC. AT-3
 13. SPECIALS SPECIFY IN ASSY/MODEL #
- BKR. PANELS WILL BE PART OF THE SYSTEM ITEM. BKR. KITS & BLOCKOFF KITS WILL BE LISTED ON THE BREAKER PANEL BOM.

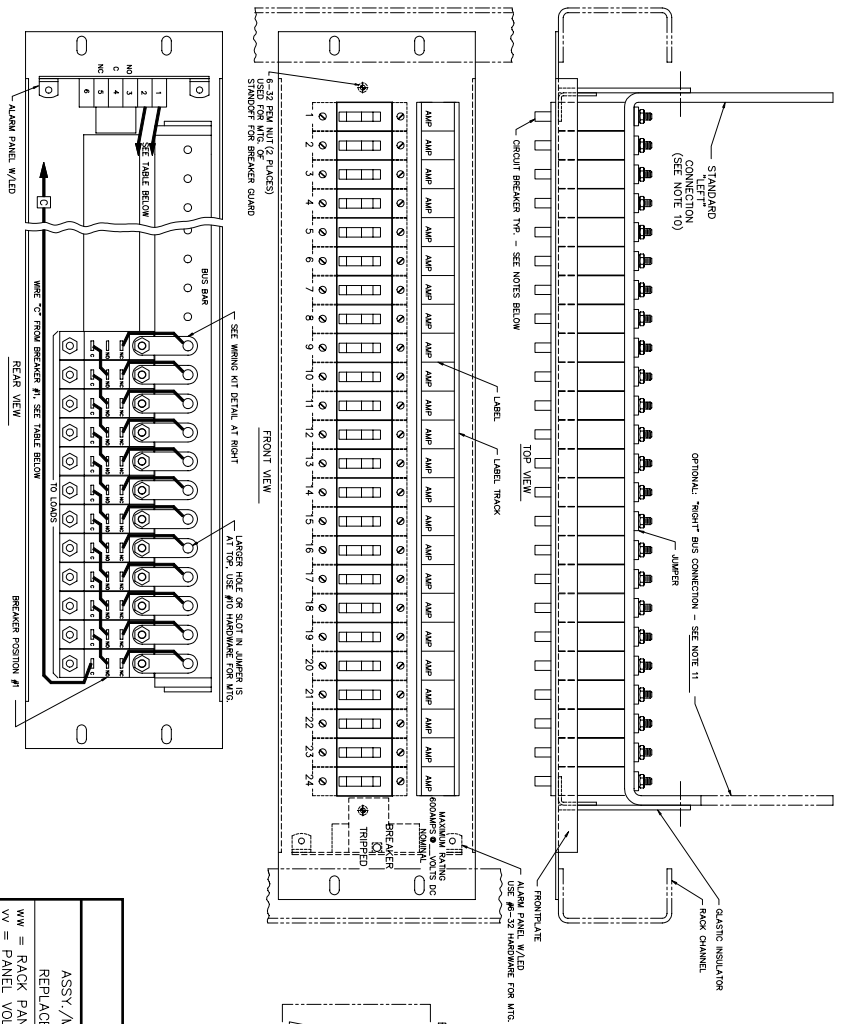

REFERENCE PART NOS. ORDER INFORMATION

P2-R8-F13A-S1	24" FRONT PLATE (2400)
P2-R8-F13A-S2	23" FRONT PLATE (2400)
P2-R8-F13A-S3	22" FRONT PLATE (2400)
P2-R8-F13A-S4	21" FRONT PLATE (2400)
P2-R8-F13A-S5	20" FRONT PLATE (2400)
P2-R8-F13A-S6	19" FRONT PLATE (2400)
P2-R8-F13A-S7	18" FRONT PLATE (2400)
P2-R8-F13A-S8	17" FRONT PLATE (2400)
P2-R8-F13A-S9	16" FRONT PLATE (2400)
P2-R8-F13A-S10	15" FRONT PLATE (2400)
P2-R8-F13A-S11	14" FRONT PLATE (2400)
P2-R8-F13A-S12	13" FRONT PLATE (2400)
P2-R8-F13A-S13	12" FRONT PLATE (2400)
P2-R8-F13A-S14	11" FRONT PLATE (2400)
P2-R8-F13A-S15	10" FRONT PLATE (2400)
P2-R8-F13A-S16	9" FRONT PLATE (2400)
P2-R8-F13A-S17	8" FRONT PLATE (2400)
P2-R8-F13A-S18	7" FRONT PLATE (2400)
P2-R8-F13A-S19	6" FRONT PLATE (2400)
P2-R8-F13A-S20	5" FRONT PLATE (2400)
P2-R8-F13A-S21	4" FRONT PLATE (2400)
P2-R8-F13A-S22	3" FRONT PLATE (2400)
P2-R8-F13A-S23	2" FRONT PLATE (2400)
P2-R8-F13A-S24	1" FRONT PLATE (2400)
P2-R8-F13A-S25	0" FRONT PLATE (2400)
P2-R8-F13A-S26	0" FRONT PLATE (2400)
P2-R8-F13A-S27	0" FRONT PLATE (2400)
P2-R8-F13A-S28	0" FRONT PLATE (2400)
P2-R8-F13A-S29	0" FRONT PLATE (2400)
P2-R8-F13A-S30	0" FRONT PLATE (2400)
P2-R8-F13A-S31	0" FRONT PLATE (2400)
P2-R8-F13A-S32	0" FRONT PLATE (2400)
P2-R8-F13A-S33	0" FRONT PLATE (2400)
P2-R8-F13A-S34	0" FRONT PLATE (2400)
P2-R8-F13A-S35	0" FRONT PLATE (2400)
P2-R8-F13A-S36	0" FRONT PLATE (2400)
P2-R8-F13A-S37	0" FRONT PLATE (2400)
P2-R8-F13A-S38	0" FRONT PLATE (2400)
P2-R8-F13A-S39	0" FRONT PLATE (2400)
P2-R8-F13A-S40	0" FRONT PLATE (2400)
P2-R8-F13A-S41	0" FRONT PLATE (2400)
P2-R8-F13A-S42	0" FRONT PLATE (2400)
P2-R8-F13A-S43	0" FRONT PLATE (2400)
P2-R8-F13A-S44	0" FRONT PLATE (2400)
P2-R8-F13A-S45	0" FRONT PLATE (2400)
P2-R8-F13A-S46	0" FRONT PLATE (2400)
P2-R8-F13A-S47	0" FRONT PLATE (2400)
P2-R8-F13A-S48	0" FRONT PLATE (2400)
P2-R8-F13A-S49	0" FRONT PLATE (2400)
P2-R8-F13A-S50	0" FRONT PLATE (2400)
P2-R8-F13A-S51	0" FRONT PLATE (2400)
P2-R8-F13A-S52	0" FRONT PLATE (2400)
P2-R8-F13A-S53	0" FRONT PLATE (2400)
P2-R8-F13A-S54	0" FRONT PLATE (2400)
P2-R8-F13A-S55	0" FRONT PLATE (2400)
P2-R8-F13A-S56	0" FRONT PLATE (2400)
P2-R8-F13A-S57	0" FRONT PLATE (2400)
P2-R8-F13A-S58	0" FRONT PLATE (2400)
P2-R8-F13A-S59	0" FRONT PLATE (2400)
P2-R8-F13A-S60	0" FRONT PLATE (2400)
P2-R8-F13A-S61	0" FRONT PLATE (2400)
P2-R8-F13A-S62	0" FRONT PLATE (2400)
P2-R8-F13A-S63	0" FRONT PLATE (2400)
P2-R8-F13A-S64	0" FRONT PLATE (2400)
P2-R8-F13A-S65	0" FRONT PLATE (2400)
P2-R8-F13A-S66	0" FRONT PLATE (2400)
P2-R8-F13A-S67	0" FRONT PLATE (2400)
P2-R8-F13A-S68	0" FRONT PLATE (2400)
P2-R8-F13A-S69	0" FRONT PLATE (2400)
P2-R8-F13A-S70	0" FRONT PLATE (2400)
P2-R8-F13A-S71	0" FRONT PLATE (2400)
P2-R8-F13A-S72	0" FRONT PLATE (2400)
P2-R8-F13A-S73	0" FRONT PLATE (2400)
P2-R8-F13A-S74	0" FRONT PLATE (2400)
P2-R8-F13A-S75	0" FRONT PLATE (2400)
P2-R8-F13A-S76	0" FRONT PLATE (2400)
P2-R8-F13A-S77	0" FRONT PLATE (2400)
P2-R8-F13A-S78	0" FRONT PLATE (2400)
P2-R8-F13A-S79	0" FRONT PLATE (2400)
P2-R8-F13A-S80	0" FRONT PLATE (2400)
P2-R8-F13A-S81	0" FRONT PLATE (2400)
P2-R8-F13A-S82	0" FRONT PLATE (2400)
P2-R8-F13A-S83	0" FRONT PLATE (2400)
P2-R8-F13A-S84	0" FRONT PLATE (2400)
P2-R8-F13A-S85	0" FRONT PLATE (2400)
P2-R8-F13A-S86	0" FRONT PLATE (2400)
P2-R8-F13A-S87	0" FRONT PLATE (2400)
P2-R8-F13A-S88	0" FRONT PLATE (2400)
P2-R8-F13A-S89	0" FRONT PLATE (2400)
P2-R8-F13A-S90	0" FRONT PLATE (2400)
P2-R8-F13A-S91	0" FRONT PLATE (2400)
P2-R8-F13A-S92	0" FRONT PLATE (2400)
P2-R8-F13A-S93	0" FRONT PLATE (2400)
P2-R8-F13A-S94	0" FRONT PLATE (2400)
P2-R8-F13A-S95	0" FRONT PLATE (2400)
P2-R8-F13A-S96	0" FRONT PLATE (2400)
P2-R8-F13A-S97	0" FRONT PLATE (2400)
P2-R8-F13A-S98	0" FRONT PLATE (2400)
P2-R8-F13A-S99	0" FRONT PLATE (2400)
P2-R8-F13A-S100	0" FRONT PLATE (2400)

DWG. A-BPK-2 ECN 14193

ASSY./MODEL NO. DESCRIPTION: ●BPKww-vvbw-prrgfs
 REPLACE lower case letters WITH DATA PER LEGEND BELOW

- ww = RACK PANEL WIDTH: 19 OR 23
- vv = PANEL VOLTAGE: 12, 24, OR 48
- b = BUS CONNECTION (PER NOTES 10 & 11): L = LEFT (STD.), R = RIGHT (SPL.)
- pp = POSITIONS MAX: 24 OR 18 PER NOTES 6 & 7
- r = ALARM: R = WITH ALARM
- g = GROUND: NONE = POS. GND, N = NEG. GND.
- f = FINISH: NONE = ANS#-61 GREY, OTHER LETTERS FOR SPECIALS PER SPEC AT-3
- s = SPECIFIC BOM NO. INCLUDING BREAKER KITS & BLOCKOFF KITS.

**Model FPR Series
Form 101 Fuse Panels With Alarm**



Model Number Nomenclature					
Model Number	Rack Mounting	DC Voltage	Ground	Fuse Blocks	DC Amp Range
FPR	()	()	()	()	()

When Ordering Please Specify:
Model Number
Rack Mounting
DC Voltage
Ground
Fuse Blocks
DC Amp Range

Model Number	
FPR	Form 101 Fuse Panel With Alarm

Ground	
-	Positive
N	Negative

Model Number	Number of Fuse Blocks	DC Amp Range	Rack Mounting (inches)	Rack Units
24V				
FPR19-24V1-1AS400	1	70-400	19	3
FPR19-24V1-2AS400	2	70-400	19	3
FPR19-24V1-1AS600	1	70-600	19	3
FPR19-24V1-2AS600	2	70-600	19	3
FPR23-24V1-1AS400	1	70-400	23	3
FPR23-24V1-2AS400	2	70-400	23	3
FPR23-24V1-1AS600	1	70-600	23	3
FPR23-24V1-2AS600	2	70-600	23	3
FPR19-24V1N-1AS400	1	70-400	19	3
FPR19-24V1N-2AS400	2	70-400	19	3
FPR19-24V1N-1AS600	1	70-600	19	3
FPR19-24V1N-2AS600	2	70-600	19	3
FPR23-24V1N-1AS400	1	70-400	23	3
FPR23-24V1N-2AS400	2	70-400	23	3
FPR23-24V1N-1AS600	1	70-600	23	3
FPR23-24V1N-2AS600	2	70-600	23	3
48V				
FPR19-48V1-1AS400	1	70-400	19	3
FPR19-48V1-2AS400	2	70-400	19	3
FPR19-48V1-1AS600	1	70-600	19	3
FPR19-48V1-2AS600	2	70-600	19	3
FPR23-48V1-1AS400	1	70-400	23	3
FPR23-48V1-2AS400	2	70-400	23	3
FPR23-48V1-1AS600	1	70-600	23	3
FPR23-48V1-2AS600	2	70-600	23	3

Fuses Are Not Included On Panel Prices Listed Above (See Optional FPR Fuse Prices Below)

Optional FPR Fuses	
Model Number	Amp Rating
P8-A1-A70	70
P8-A1-A80	80
P8-A1-A90	90
P8-A1-A100	100
P8-A1-A150	150
P8-A1-A200	200
P8-A1-A250	250
P8-A1-A300	300
P8-A1-A350	350
P8-A1-A400	400
P8-A3-A500	500
P8-A3-A600	600

Fuses Must Be Ordered As A Separate Line Item & Will Be Shipped Loose From Fuse Panel

Single Pole Circuit Breaker Distribution Panel

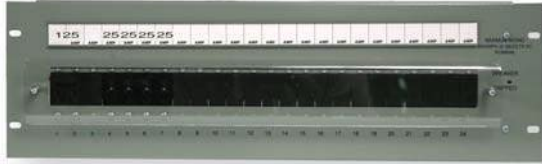

Typical BPKR Model Shown

Circuit Breaker Distribution Panels are designed to provide protection for multiple load/distribution circuits. The circuit breakers' fast trip response assures the panel breaker will trip before the main circuit breaker/fuse, so that power will not be interrupted from other critical DC loads if an overload occurs. Return Bus is conveniently located on the same panel to facilitate installation.

BPKR panels utilize UL recognized breakers with an interrupting capacity of 5,000 amps DC at 65 volts.

Model Number Nomenclature

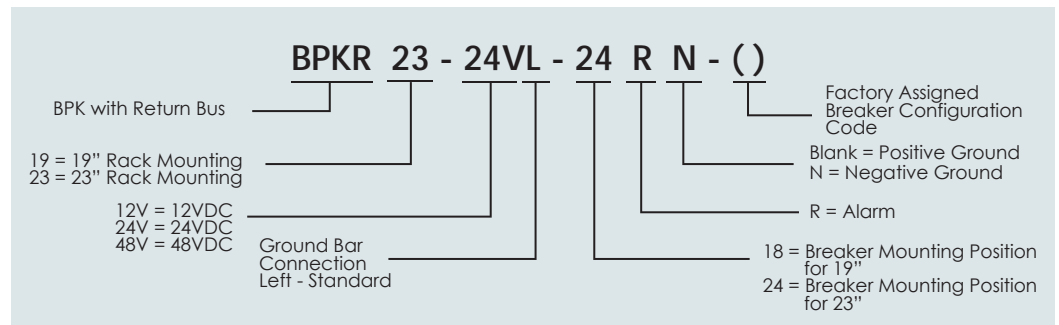

Breaker Size (Amps)	Breaker Terminals	Position Occupied
1	10 - 32 Stud	One Position
2		
3		
5		
10		
15		
20		
25		
30		
35		
40	1/4 - 20 Stud	Two Position
50		
60		Four Position
70		
80	1/4 - 20 Stud	Two Position
90		
100		
125	1/4 - 20 Stud	Four Position
150		

Standard Features

- 12, 24, or 48 volts DC Ratings available
- Positive or Negative ground
- Guard Kit to prevent accidental tripping of breakers
- Blank fillers furnished for all unused breaker positions
- Breaker designation label track
- Alarm LED light and form "C" relay alarm contacts. The relay will be activated if any breaker in the panel trips or is shut off
- Available breaker sizes are 1 - 150 amps single pole
- Finish - ANSI - 61 gray paint



La MARCHÉ

ISO 9001:2000 CERTIFIED

LVLD SERIES

LOW VOLTAGE LOAD DISCONNECT PANEL

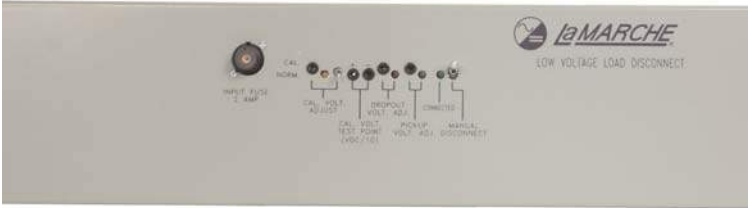

MODEL LVLD SERIES

LOW VOLTAGE LOAD DISCONNECT PANEL

The La Marche Low Voltage Load Disconnect (LVLD) panels automatically disconnect the DC load from the battery by means of a heavy-duty contactor. If the battery voltage drops below the preset level, a drop-out LED indicator on the front panel will illuminate and an alarm relay will de-energize, thus causing the contacts to change state. The load is reconnected automatically when the battery voltage returns to the desired voltage.

The calibration mode allows adjustments to the drop-out and pull-in set points on a live system without disturbing the system voltage or the load.

Standard Features

- Front access mounted test points, controls, fuse and LED's
- Field adjustable drop out and pick up voltages
- Manual disconnect switch with locking toggle lever
- Calibration Mode
- LED indicators for:
 - Load Connected
 - Calibration Voltage Adjust
 - Pick Up Voltage Adjust
- Two sets of form "C" low voltage alarm contacts
- Finish – ANSI-61 grey paint
- Coil of DC contactor fuse protected

Optional Features

- Enclosed wall mounted low voltage load disconnects. Consult the factory for details.
- Special paint finishes

Dimensions

- Height

50-400 amps	5.250 inches (3RU's)
600-1200 amps	8.750 inches (5RU's)
- Width

19 or 23 inches wide Relay Rack Panels
--
- Weight of panel mounted low voltage load disconnects (approx.)

50-100 amps	5 lbs.
200-400 amps	8 lbs.
600-800 amps	10 lbs.
1200 amps	15 lbs.

Voltage and Current Ratings

- 12, 24, or 48 volts DC ratings available. Must indicate negative common (return) as part of model number format when applicable. See model format for details.
- DC current ratings available: 50-1200 amps

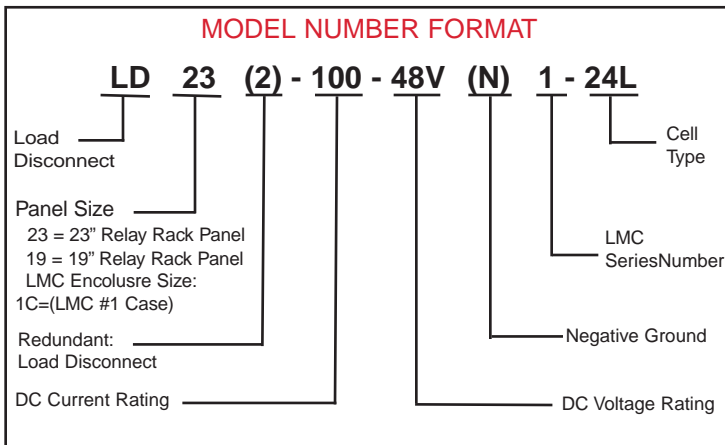

**Model CE Series
Counter EMF Panel**

Model Number Nomenclature						
Model Number	DC Voltage	DC Amps	DC Voltage Drop	Rack Mounting	Ground	Battery Cell Range
CE	24	50A	()	()	()	()

When Ordering Please Specify:	
Model Number	
DC Voltage	
DC Amps	
DC Voltage Drop	
Rack Mounting	
Ground	
Battery Cell Range	

Ground	
-	Positive
N	Negative

Battery Cell Range*	
12L	24V
24L	48V

Model Number	DC Voltage Drop	Rack Mounting (inches)	Rack Units
24V			
CE24-50A-4V19	4V	19	9
CE24-100A-4V19	4V	19	11
CE24-200A-4V19	4V	19	19
CE24-50A-3V19	3V	19	9
CE24-100A-3V19	3V	19	11
CE24-200A-3V19	3V	19	19
CE24-50A-4V19N	4V	19	9
CE24-100A-4V19N	4V	19	11
CE24-200A-4V19N	4V	19	19
CE24-50A-3V19N	3V	19	9
CE24-100A-3V19N	3V	19	11
CE24-200A-3V19N	3V	19	19
CE24-50A-4V23	4V	23	9
CE24-100A-4V23	4V	23	11
CE24-200A-4V23	4V	23	19
CE24-400A-4V23A	4V	23	20
CE24-50A-3V23	3V	23	9
CE24-100A-3V23	3V	23	11
CE24-200A-3V23	3V	23	19
CE24-400A-3V23A	3V	23	20
CE24-50A-4V23N	4V	23	9
CE24-100A-4V23N	4V	23	11
CE24-200A-4V23N	4V	23	19
CE24-400A-4V23AN	4V	23	20
CE24-50A-3V23N	3V	23	9
CE24-100A-3V23N	3V	23	11
CE24-200A-3V23N	3V	23	19
CE24-400A-3V23AN	3V	23	20
48V			
CE48-50A-4V19	4V	19	9
CE48-100A-4V19	4V	19	11
CE48-200A-4V19	4V	19	19
CE48-50A-3V19	3V	19	9
CE48-100A-3V19	3V	19	11
CE48-200A-3V19	3V	19	19
CE48-50A-4V23	4V	23	9
CE48-100A-4V23	4V	23	11
CE48-200A-4V23	4V	23	19
CE48-400A-4V23A	4V	23	20
CE48-50A-3V23	3V	23	9
CE48-100A-3V23	3V	23	11
CE48-200A-3V23	3V	23	19
CE48-400A-3V23A	3V	23	20

*Consult Factory For Pricing On Battery Ranges Not Listed
Refer To The Model CE Series Data Sheet For Further Details

Model MP Series

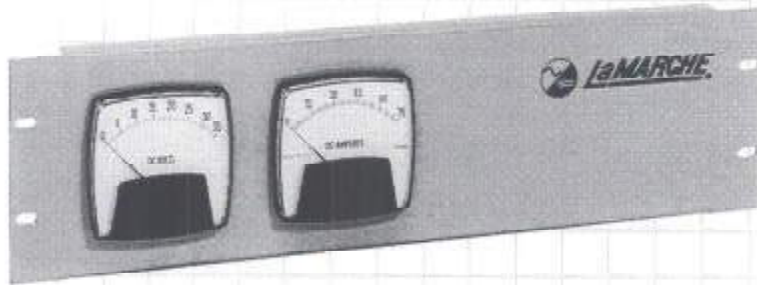

Meter Panels

GENERAL DESCRIPTION

Meter panels are provided to measure the DC voltage and current of the system. Panels are 5-1/4 inches high (3 rack units). Standard meter accuracy is 2%. Optional 1% meters are available at an additional cost. Shunts are supplied for ratings 75 amps and above. 24 VDC panels have 35 VDC scales. 48 VDC panels have 75 VDC scales.

Model Number Nomenclature

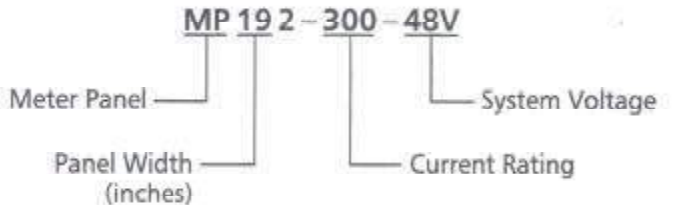

23 Inch Panel

Model Number	Ampere Rating	DC Voltage	Ammeter Scale
MP232-25-24V	25	24	30
MP232-25-48V	25	48	30
MP232-50-24V	50	24	75
MP232-50-48V	50	48	75
MP232-75-24V	75	24	100
MP232-75-48V	75	48	100
MP232-100-24V	100	24	150
MP232-100-48V	100	48	150
MP232-150-24V	150	24	200
MP232-150-48V	150	48	200
MP232-200-24V	200	24	250
MP232-200-48V	200	48	250
MP232-300-24V	300	24	400
MP232-300-48V	300	48	400
MP232-400-24V	400	24	500
MP232-400-48V	400	48	500

19 Inch Panel

Model Number	Ampere Rating	DC Voltage	Ammeter Scale
MP192-25-24V	25	24	30
MP192-25-48V	25	48	30
MP192-50-24V	50	24	75
MP192-50-48V	50	48	75
MP192-75-24V	75	24	100
MP192-75-48V	75	48	100
MP192-100-24V	100	24	150
MP192-100-48V	100	48	150
MP192-150-24V	150	24	200
MP192-150-48V	150	48	200
MP192-200-24V	200	24	250
MP192-200-48V	200	48	250
MP192-300-24V	300	24	400
MP192-300-48V	300	48	400
MP192-400-24V	400	24	500
MP192-400-48V	400	48	500

Note: Optional battery/system DC voltage switch is available. Please consult the factory for pricing and availability. All specifications are subject to change without notice. Please consult the factory for current listing.



106 Bradrock Drive, Des Plaines, IL USA 60018-1967

Phone: 847/299-1188

E-mail: sales@lamarchemfg.com

Fax: 847/299-3061

Web: www.lamarchemfg.com

TABLE OF CONTENTS

**Model DSA
Digital Status Alarm Panel**

Model Number Nomenclature				
Model Number	Rack Mounting	DC Amps	DC Voltage	Ground
()	()	()	()	()

When Ordering Please Specify:
Model Number
Rack Mounting
DC Amps
DC Voltage
Ground

Ground	
-	Positive
N	Negative

Model Number	Rack Mounting (inches)	Rack Units
24V		
DSA19-200A-24V	19	4
DSA19-400A-24V	19	4
DSA19-600A-24V	19	4
DSA19-800A-24V	19	4
DSA23-200A-24V	23	4
DSA23-400A-24V	23	4
DSA23-600A-24V	23	4
DSA23-800A-24V	23	4
DSA19-200A-24VN	19	4
DSA19-400A-24VN	19	4
DSA19-600A-24VN	19	4
DSA19-800A-24VN	19	4
DSA23-200A-24VN	23	4
DSA23-400A-24VN	23	4
DSA23-600A-24VN	23	4
DSA23-800A-24VN	23	4
48V		
DSA19-200A-48V	19	4
DSA19-400A-48V	19	4
DSA19-600A-48V	19	4
DSA19-800A-48V	19	4
DSA23-200A-48V	23	4
DSA23-400A-48V	23	4
DSA23-600A-48V	23	4
DSA23-800A-48V	23	4

Consult Factory For Availability Of Higher Current Capacities

P25-DSDSA-1
ECN 16625
01-05



Battery Tray

La Marche Relay Rack Mounted Battery Trays are beneficial if floor space is confined and batteries are to be mounted directly in the DC power system equipment racks.

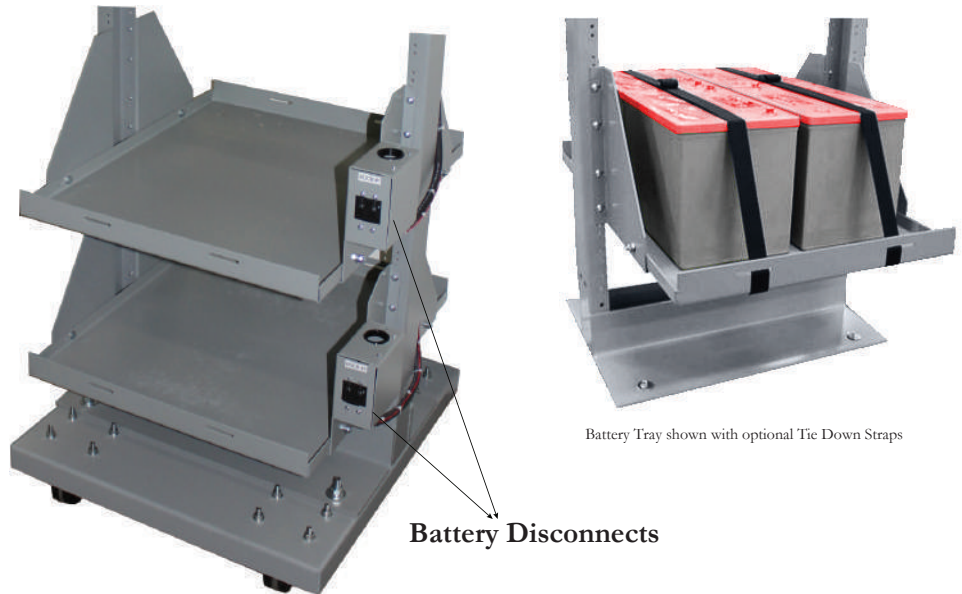

Battery Tray shown with Battery Disconnects

Battery Tray shown with optional Tie Down Straps

Battery Disconnects

Standard Features

- Constructed from 12 gauge steel
- ANSI-61 gray paint finish
- Assembly and mounting hardware
- Welded corners
- 600 lbs weight capacity

Options

(Consult factory for further details)

- Battery Tie Down Strap Kit
- Special Battery Tray size
- Battery Disconnect 150A rated

Model Number	Battery Disconnect	Rack Mounting		Width		Depth		Weight		Weight capacity	
		in	mm	in	mm	in	mm	lbs	kg	lbs	kg
P3-RRB-A03A	---	19	482.6	17	432	19	482.6	25	11.3	500	226.8
P3-RRB-A04A	---	19	482.6	17	432	28	711.2	30	13.6	500	226.8
P3-RRB-A07A	---	23	584.2	21	533	28	711.2	35	15.9	600	272.1
P3-RRB-A08A	---	23	584.2	21	533	25	635	34	15.4	600	272.1
P3-RRB-A14A	✓	23	584.2	21	533	25	635	34	15.4	600	272.1
P3-RRB-A15A	✓	19	482.6	17	432	25	635	34	15.4	500	226.8
S4C-TRAY-1	Tie Down Strap for Battery Tray										

Specifications subject to change without notice

P25-DSBT-1
ECN 20715
01/15

La Marche Mfg. (A U.S. Company)
106 Bradrock Drive, Des Plaines, IL 60018
Tel: 847.299.1188 Fax: 847.299.3061
sales@lamarchemfg.com
www.lamarchemfg.com





La MARCHE®

ISO 9001:2000 CERTIFIED

BLANK PANEL



Standard Features

- Constructed from 14 gauge steel
- ANSI-61 gray paint finish
- Mounting hardware
- 1.75 inch mounting hole pattern

Options

(Consult factory for further details.)

- Vented front panel

**FRONT MOUNTED
BLANK PANEL**

The front mounted blank panels can be used to shield exposed bus work from the front of the rack assembly to allow for easy expansion of an existing power rack system.

Standard Blank Panel Chart for 19" Rack

Model Number	Height (inches)	Rack Width* (inches)	Rack Units
P3-RR-F72A	1.75	19	1
P3-RR-F21A	3.50	19	2
P3-RR-F20A	5.25	19	3
P3-RR-F28A	7.00	19	4
P3-RR-F41A	8.75	19	5
P3-RR-F22A	10.50	19	6
P3-RR-F29A	12.25	19	7
P3-RR-F30A	15.75	19	9
P3-RR-F39A	17.50	19	10

*Center to center is 18.25 inches.

Standard Blank Panel Chart for 23" Rack

Model Number	Height (inches)	Rack Width** (inches)	Rack Units
P3-RR-F73A	1.75	23	1
P3-RR-F18A	3.50	23	2
P3-RR-F23A	5.25	23	3
P3-RR-F50A	7.00	23	4
P3-RR-F43A	8.75	23	5
P3-RR-F24A	10.50	23	6
P3-RR-F32A	12.25	23	7
P3-RR-F37A	15.75	23	9
P3-RR-F40A	17.50	23	10

**Center to center is 22.25 inches.

Specifications are subject to change without notice.

P25-DSBLKP-1
ECN 16713
03-05

La Marche Manufacturing Company
106 Bradrock Drive, Des Plaines, IL 60018-1967
Tel: 1-847-299-1188 Toll Free Fax: 1-888-232-9562
sales@lamarchemfg.com www.lamarchemfg.com

Made in USA



La MARCHÉ®

ISO 9001:2000 CERTIFIED

HEAT BAFFLE

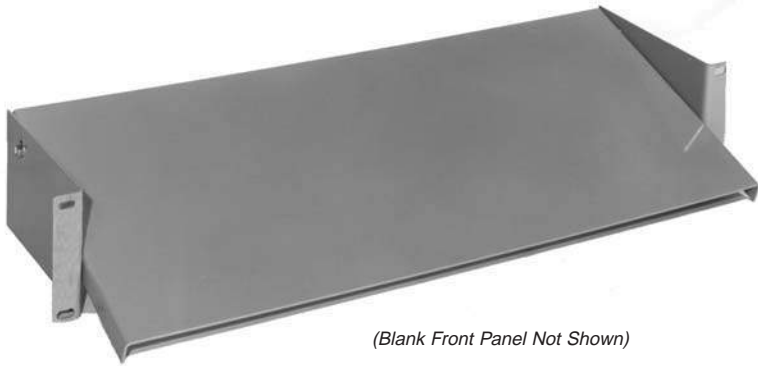

(Blank Front Panel Not Shown)

Standard Features

- Constructed from 14 gauge steel
- ANSI-61 gray paint finish
- 2 side plates, baffle plate and a blank front panel
- Mounting hardware

Options

(Consult factory for further details.)

- Vented front panel
- Special Heat Baffle size

HEAT BAFFLE

Heat Baffles are attached to the Relay Rack generally above or between any heat-generating piece(s) of equipment.

The baffle will divert the heat away from sensitive components/equipment mounted above the Heat Baffle.

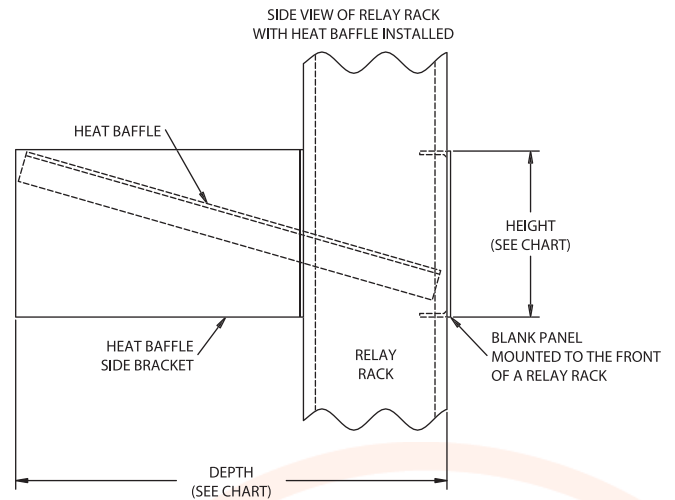

Heat Baffle Chart

Model Number	Height (inches)	Rack Width (inches)	Depth (inches)	Rack Units
HB19-350	3.50	19	9.00	2
HB23-350	3.50	23	9.00	2

Specifications are subject to change without notice.

P25-DSBLKP-1
ECN 16713
03-05

La Marche Manufacturing Company
106 Bradrock Drive, Des Plaines, IL 60018-1967
Tel: 1-847-299-1188 Toll Free Fax: 1-888-232-9562
sales@lamarchemfg.com www.lamarchemfg.com

Made in USA

Mount, Wire & Test Miscellaneous Panels

Mount Wire & Test	
Group	Description
1	Up To Five (5) Items On One (1) Rack
2	Six (6) To Eight (8) Items On One (1) Rack
3	Nine (9) To Ten (10) Items On One (1) Rack
4	Five (5) To Fifteen (15) Items On Two (2) Racks

Racks And Blank Panels **Do Not** Count As Items

P25-DSMWT
ECN 16625
01-05

When assembling a Relay Rack System that is made up of several pieces of equipment, the pieces must be properly mounted, wired, & tested to function properly. The list above shows how La Marche groups the different levels of labor that must go into a Relay Rack System

Model PBS - Page 1 of 3
Protective Back & Sides

Model Number Nomenclature			
Model Number	Height in Rack Units	Depth in Inches	Width in Inches
S4L	()	8D	()

When Ordering Please Specify:
Model Number
Height in Rack Units
Depth in Inches
Width in Inches

For Areas Larger Than 29 Rack Units Use A Combination Of Kits. (See Examples Below)	
35 Rack Units	Use (1) S4L-15RU-8D-23W and (1) S4L-20RU-8D-23W
43 Rack Units	Use (1) S4L-20RU-8D-23W and (1) S4L-23RU-8D-23W

Model Number	Rack Units	Depth (inches)	Width (inches)
S4L-2RU-8D-19W	2	8	19
S4L-4RU-8D-19W	4	8	19
S4L-6RU-8D-19W	6	8	19
S4L-7RU-8D-19W	7	8	19
S4L-8RU-8D-19W	8	8	19
S4L-10RU-8D-19W	10	8	19
S4L-11RU-8D-19W	11	8	19
S4L-12RU-8D-19W	12	8	19
S4L-13RU-8D-19W	13	8	19
S4L-14RU-8D-19W	14	8	19
S4L-15RU-8D-19W	15	8	19
S4L-16RU-8D-19W	16	8	19
S4L-17RU-8D-19W	17	8	19
S4L-18RU-8D-19W	18	8	19
S4L-19RU-8D-19W	19	8	19
S4L-20RU-8D-19W	20	8	19
S4L-22RU-8D-19W	22	8	19
S4L-23RU-8D-19W	23	8	19
S4L-24RU-8D-19W	24	8	19
S4L-25RU-8D-19W	25	8	19
S4L-26RU-8D-19W	26	8	19
S4L-28RU-8D-19W	28	8	19
S4L-29RU-8D-19W	29	8	19
S4L-2RU-8D-23W	2	8	23
S4L-4RU-8D-23W	4	8	23
S4L-6RU-8D-23W	6	8	23
S4L-7RU-8D-23W	7	8	23
S4L-8RU-8D-23W	8	8	23
S4L-10RU-8D-23W	10	8	23
S4L-11RU-8D-23W	11	8	23
S4L-12RU-8D-23W	12	8	23
S4L-13RU-8D-23W	13	8	23
S4L-14RU-8D-23W	14	8	23
S4L-15RU-8D-23W	15	8	23
S4L-16RU-8D-23W	16	8	23
S4L-17RU-8D-23W	17	8	23
S4L-18RU-8D-23W	18	8	23
S4L-19RU-8D-23W	19	8	23
S4L-20RU-8D-23W	20	8	23
S4L-22RU-8D-23W	22	8	23
S4L-23RU-8D-23W	23	8	23
S4L-24RU-8D-23W	24	8	23
S4L-25RU-8D-23W	25	8	23
S4L-26RU-8D-23W	26	8	23
S4L-28RU-8D-23W	28	8	23
S4L-29RU-8D-23W	29	8	23

Model PBS - Page 2 of 3
Protective Back & Sides

Model Number Nomenclature			
Model Number	Height in Rack Units	Depth in Inches	Width in Inches
S4L	()	12D	()

When Ordering Please Specify:
Model Number
Height in Rack Units
Depth in Inches
Width in Inches

For Areas Larger Than 29 Rack Units Use A Combination Of Kits. (See Examples Below)	
35 Rack Units	Use (1) S4L-15RU-8D-23W and (1) S4L-20RU-8D-23W
43 Rack Units	Use (1) S4L-20RU-8D-23W and (1) S4L-23RU-8D-23W

Model Number	Rack Units	Depth (inches)	Width (inches)
S4L-2RU-12D-19W	2	12	19
S4L-4RU-12D-19W	4	12	19
S4L-6RU-12D-19W	6	12	19
S4L-7RU-12D-19W	7	12	19
S4L-8RU-12D-19W	8	12	19
S4L-10RU-12D-19W	10	12	19
S4L-11RU-12D-19W	11	12	19
S4L-12RU-12D-19W	12	12	19
S4L-13RU-12D-19W	13	12	19
S4L-14RU-12D-19W	14	12	19
S4L-15RU-12D-19W	15	12	19
S4L-16RU-12D-19W	16	12	19
S4L-17RU-12D-19W	17	12	19
S4L-18RU-12D-19W	18	12	19
S4L-19RU-12D-19W	19	12	19
S4L-20RU-12D-19W	20	12	19
S4L-22RU-12D-19W	22	12	19
S4L-23RU-12D-19W	23	12	19
S4L-24RU-12D-19W	24	12	19
S4L-25RU-12D-19W	25	12	19
S4L-26RU-12D-19W	26	12	19
S4L-28RU-12D-19W	28	12	19
S4L-29RU-12D-19W	29	12	19
S4L-2RU-12D-23W	2	12	23
S4L-4RU-12D-23W	4	12	23
S4L-6RU-12D-23W	6	12	23
S4L-7RU-12D-23W	7	12	23
S4L-8RU-12D-23W	8	12	23
S4L-10RU-12D-23W	10	12	23
S4L-11RU-12D-23W	11	12	23
S4L-12RU-12D-23W	12	12	23
S4L-13RU-12D-23W	13	12	23
S4L-14RU-12D-23W	14	12	23
S4L-15RU-12D-23W	15	12	23
S4L-16RU-12D-23W	16	12	23
S4L-17RU-12D-23W	17	12	23
S4L-18RU-12D-23W	18	12	23
S4L-19RU-12D-23W	19	12	23
S4L-20RU-12D-23W	20	12	23
S4L-22RU-12D-23W	22	12	23
S4L-23RU-12D-23W	23	12	23
S4L-24RU-12D-23W	24	12	23
S4L-25RU-12D-23W	25	12	23
S4L-26RU-12D-23W	26	12	23
S4L-28RU-12D-23W	28	12	23
S4L-29RU-12D-23W	29	12	23

Model PBS - Page 3 of 3
Protective Back & Sides

Model Number Nomenclature			
Model Number	Height in Rack Units	Depth in Inches	Width in Inches
S4L	()	16D	()

When Ordering Please Specify:	
Model Number	
Height in Rack Units	
Depth in Inches	
Width in Inches	

For Areas Larger Than 29 Rack Units Use A Combination Of Kits. (See Examples Below)	
35 Rack Units	Use (1) S4L-15RU-8D-23W and (1) S4L-20RU-8D-23W
43 Rack Units	Use (1) S4L-20RU-8D-23W and (1) S4L-23RU-8D-23W

Model Number	Rack Units	Depth (inches)	Width (inches)
S4L-2RU-16D-19W	2	16	19
S4L-4RU-16D-19W	4	16	19
S4L-6RU-16D-19W	6	16	19
S4L-7RU-16D-19W	7	16	19
S4L-8RU-16D-19W	8	16	19
S4L-10RU-16D-19W	10	16	19
S4L-11RU-16D-19W	11	16	19
S4L-12RU-16D-19W	12	16	19
S4L-13RU-16D-19W	13	16	19
S4L-14RU-16D-19W	14	16	19
S4L-15RU-16D-19W	15	16	19
S4L-16RU-16D-19W	16	16	19
S4L-17RU-16D-19W	17	16	19
S4L-18RU-16D-19W	18	16	19
S4L-19RU-16D-19W	19	16	19
S4L-20RU-16D-19W	20	16	19
S4L-22RU-16D-19W	22	16	19
S4L-23RU-16D-19W	23	16	19
S4L-24RU-16D-19W	24	16	19
S4L-25RU-16D-19W	25	16	19
S4L-26RU-16D-19W	26	16	19
S4L-28RU-16D-19W	28	16	19
S4L-29RU-16D-19W	29	16	19
S4L-2RU-16D-23W	2	16	23
S4L-4RU-16D-23W	4	16	23
S4L-6RU-16D-23W	6	16	23
S4L-7RU-16D-23W	7	16	23
S4L-8RU-16D-23W	8	16	23
S4L-10RU-16D-23W	10	16	23
S4L-11RU-16D-23W	11	16	23
S4L-12RU-16D-23W	12	16	23
S4L-13RU-16D-23W	13	16	23
S4L-14RU-16D-23W	14	16	23
S4L-15RU-16D-23W	15	16	23
S4L-16RU-16D-23W	16	16	23
S4L-17RU-16D-23W	17	16	23
S4L-18RU-16D-23W	18	16	23
S4L-19RU-16D-23W	19	16	23
S4L-20RU-16D-23W	20	16	23
S4L-22RU-16D-23W	22	16	23
S4L-23RU-16D-23W	23	16	23
S4L-24RU-16D-23W	24	16	23
S4L-25RU-16D-23W	25	16	23
S4L-26RU-16D-23W	26	16	23
S4L-28RU-16D-23W	28	16	23
S4L-29RU-16D-23W	29	16	23



Approval Agency Listings

10/13/17

MODEL	APPROVAL AGENCY
A12B	UL (1012); UL (1481); C-UL; ABS
A18J	CSA C22.2 No. 107.2-01
A20R	CSA C22.2 No. 107.2-01
A31	UL (1012); C-UL; UL (1481)
A36D	UL (1012); UL (1481); C-UL
A40	UL (1564); C-UL
A41	UL (1236)
A45E	UL (1564), C-UL
A46	UL (1564); C-UL; ABS
A48	UL (1236)
A48B	UL (1236)
A70B	UL (1564); C-UL
A75D/DE	UL (1012); C-UL (Single Phase Only) ; ABS
A77	UL (1012); C-UL; ABS
AGVB	C-UL; UL (1564)
AVIA	UL (1564)
CCFB	UL (1564); C-UL
EC	UL (1564); C-UL
ESCR	UL (1236); C-UL; CE; ABS
LMHF	UL (60950-1); CSA; IEC; CE
MSM	UL (1236); C-UL; ABS; CE
TPSD	UL (1012); C-UL; ABS
TPC	UL (1012); C-UL
TPM	UL (1012); C-UL
USC	UL (1236); C-UL

Models with Pending Approval Agency Listings

MODEL	APPROVAL AGENCY
LTP	UL (1012)

Note: This is a general guide. Not all models or options may be approved. Please consult the individual data sheet for which models or options are approved.



Case Specifications
Standard & Rack Mounted Cases

Volume Date: March 1, 2015	Revision: 02 Rev. Date: 3/1/2018
----------------------------	-------------------------------------

Case NO.	Width		Depth		Height		Mounting	Rack Mounting (inches)	Rack Units
	in	mm	in	mm	in	mm			
1	10.375	264	7.875	200	16.250	413	Wall	N/A	N/A
02	5.125	130	7.125	181	11.250	286	Wall	N/A	N/A
02C	5.000	127	5.250	133	7.250	184	Wall	N/A	N/A
2	12.812	326	10.000	254	17.125	435	Wall	N/A	N/A
3	15.375	391	11.000	279	23.750	603	Wall/Floor	N/A	N/A
4*	16.878	429	15.000	381	25.875	657	Floor/Wall	19 & 23	14
4_23	16.750	425	15.000	381	24.000	610	23"RR	23	N/A
4_30	16.750	425	15.000	381	24.000	610	30"RR	30	N/A
475	19.000	483	15.000	381	24.000	610	Wall	19"/23"	14
477	19.000	483	15.716	399	23.688	602	Wall	19"/23"	14
4A	16.750	425	15.000	381	36.000	914	19"RR	19	N/A
4A-23	16.750	425	15.000	381	36.000	914	23"RR	23	N/A
4A-30	16.750	425	15.000	381	36.000	914	3"RR	30	N/A
4B* or 10	16.878	429	15.000	381	14.050	357	Floor/Wall	19 & 23	7
4B-23	16.750	425	15.000	381	12.250	311	23"RR	23	N/A
4B75	19.000	483	15.000	381	12.000	310	Wall	19"/23"	N/A
4D	16.750	425	15.000	381	14.000	356	N/A	19 & 23	8
4D-23	16.750	425	15.000	381	14.000	356	23"RR	23	N/A
4E	19.000	483	15.716	399	23.688	602	Wall	19"/23"	14
05	8.000	203	7.000	178	13.000	330	Wall	N/A	N/A
6	25.580	650	13.935	354	28.000	711	Wall/Floor	N/A	N/A
7	14.250	362	10.625	270	19.875	505	Wall/Floor	N/A	N/A
7B	19.875	505	9.000	229	14.250	362	Base Plate	N/A	N/A
8A	27.200	691	15.250	387	32.500	826	Floor	N/A	N/A
9*	20.735	527	15.000	381	37.875	962	Floor	23 & 30	21
9_30	20.750	527	15.000	381	36.000	914	30"RR	30	N/A
975	20.735	527	15.000	381	37.875	962	Floor	23 & 30	21
977	20.500	521	15.875	403	37.875	962	Floor	23 & 30	21
9B	20.750	527	15.000	381	21.000	533	23"RR	23	N/A
9B-30	20.750	527	15.000	381	21.000	533	30"RR	30	N/A
9D**	21.000	533	15.000	381	17.250	438	N/A	23	10
9D-30	21.000	533	15.000	381	17.500	438	23"RR	30	N/A
9E**	21.000	533	20.000	508	17.250	438	N/A	23	10
27	27.312	694	25.875	657	56.125	1426	Floor	N/A	N/A
33***	21.000	533	15.000	381	10.500	267	N/A	23	6
33_23	16.750	425	15.000	381	7.000	178	23"RR	23	N/A
33E	21.000	533	17.750	445	10.500	267	N/A	23	6
39	16.750	425	15.000	381	7.000	178	N/A	19 & 23	4
40	16.880	411	9.500	241	13.000	330	Shelf/Wall	N/A	N/A
41	24.000	610	13.250	337	14.000	356	Shelf/Wall	N/A	N/A
43	13.000	330	19.000	483	84.000	2134	Floor	N/A	N/A
44	24.000	610	19.000	483	72.100	1831	Floor	N/A	N/A
47	39.250	965	39.375	1000	70.000	1778	Floor	N/A	N/A
47N	35.400	899	33.400	848	67.500	1715	Floor	N/A	N/A
47B	39.250	965	47.000	1194	71.000	1803	Floor	N/A	N/A
57	60.000	1524	36.000	914	80.000	2032	Floor	N/A	N/A
57N	60.000	1524	30.055	763	77.250	1962	Floor	N/A	N/A
68	27.000	686	15.000	381	27.500	6985	Floor	N/A	N/A
70	27.000	686	19.000	483	41.000	1041	Floor	N/A	N/A
72	27.000	686	23.500	597	44.500	1130	Floor	N/A	N/A
72N	27.000	686	24.435	621	43.650	1109	Floor	N/A	N/A
74	9.000	229	8.687	221	11.500	292	Wall	N/A	N/A
83	13.375	340	8.687	221	16.500	419	Floor	N/A	N/A
108	20.000	508	17.000	432	22.000	559	Floor	N/A	N/A
109	23.250	591	20.250	514	30.275	769	Floor	N/A	N/A

*When Rack Mounting The Case, Subtract 1.875 Inches From Height For Floor Mounting Brackets
 **Add 3.000 Inches To Depth For Heat Sink
 ***Add 1.250 Inches To Depth For Heat Sink

TABLE OF CONTENTS

Model	Technology	Filtering for VRLA	Battery Eliminator	Breakers	Temp. Comp.	Ground Dck.	Load Sharing	Comm.	UL Listing	NEMA PES	Meets NFPA110	Meets USCG	ABS Type Approved	Warranty
A40	Controlled Mag-Amp								1564					10 Yrs Ltd
A40F	Controlled Mag-Amp	■							1564					10 Yrs Ltd
A41	Controlled Mag-Amp								1236			•		10 Yrs Ltd
A41F	Controlled Mag-Amp	■							----			•		10 Yrs Ltd
A46	Controlled Mag-Amp			○					1564		○	○	○	10 Yrs Ltd
A46F	Controlled Mag-Amp	■		○					1564		○	○	○	10 Yrs Ltd
MSCR	Controlled SCR	■			■				1236			■	■	3 Yrs
MSM	Switchmode	■			■				----			■		2 Yrs
A75R	Controlled SCR	■			■				----					3 Yrs
RHF	Switchmode	■			■				----					2 Yrs
EC	Ferro								1236		○			2 Yrs
ESCR	Controlled SCR	■			■				1236		■			3 Yrs
A12B	Controlled Mag-Amp	■	■	○	○	○	○	○	1012, 1481	■	○	○	○	10 Yrs Ltd
A77D	Controlled SCR	■		■	■	■	■	○	1012	■	■			3 Yrs
A77DE	Controlled SCR	■	■	■	■	■	■	○	1012	■	■			3 Yrs
A97	Switchmode	■	■	■	○	○	○	○	----	■	○			1 Yrs
TPSD	Controlled Ferro	■	■	■	■	■	■	○	1012	■	■		○	5 Yrs Ltd
A36D	Controlled Ferro	■	■	■	■		■	○	1012, 1481		■			5 Yrs Ltd
LMHF	Switchmode	■	■		○		■	■	CSA					2 Yrs
TPM	Switchmode	■	■	■			■		1012					2 Yrs
LTP	Switchmode	■					■	○	----					2 Yrs
A20R	Straight Transformer								CSA					2 Yrs
A18J	Straight Transformer								CSA					2 Yrs
A31	Controlled Ferro			■				○	1012, 1481					5 Yrs Ltd
A48	Controlled Mag-Amp								1236					10 Yrs
A48B	Controlled Mag-Amp								1236					10 Yrs
A63	Switchmode	■	■	■			■		----					2 Yrs Ltd
IX	Switchmode			■			■	○	60950					2 Yrs
A32P	Controlled Ferro	■	■	■					1481					5 Yrs Ltd
A32S	Controlled Ferro	■	■	■					1481					5 Yrs Ltd

Key: Option = ○ Standard = ■

Notes: Please see Data Sheet for more detailed information



La MARCHÉ

TABLE OF CONTENTS

MANUFACTURER'S WARRANTY

All La Marche Manufacturing Co. equipment has been thoroughly tested and found to be in proper operating condition upon shipment from the factory and is warranted to be free from any defect in workmanship and material that may develop within five (5) years from date of purchase.

Any part or parts of the equipment (except fuses, d.c. connectors and other wear-related items) that prove defective within a five (5) year period shall be replaced without charge providing such defect, in our opinion, is due to faulty material or workmanship and not caused by tampering, abuse, misapplication or improper installation.

Should a piece of equipment require repair during the warranty period, the equipment can be returned to the La Marche factory to have the inspection, parts replacements and testing performed by factory personnel. Should it be necessary to return a piece of equipment or parts to the factory, the customer or sales representative must obtain authorization from the factory. If upon inspection at the factory, the defect was due to faulty material or workmanship, all repairs will be made at no cost to the customer during the first five years. Transportation charges or duties shall be borne by purchaser.

In accepting delivery of the equipment, the purchaser assumes full responsibility for proper installation, installation adjustments and service arrangements. Should minor adjustments be required, the local La Marche sales representative should be contacted to provide this service only.

All sales are final. Only standard LaMarche units will be considered for return. A 25% restocking fee is charged when return is factory authorized. Special units are not returnable.

In no event shall La Marche Manufacturing Co. have any liability for consequential damages, or loss, damage or expense directly or indirectly arising from the use of the products, or any inability to use them either separately or in combination with other equipment or materials, or from any other cause. In addition, any alterations of equipment made by anyone other than La Marche Manufacturing Co. renders this warranty null and void.

La Marche Manufacturing Co. reserves the right to make revisions in current production of equipment, and assumes no obligation to incorporate these revisions in earlier models.

The failure of La Marche Manufacturing Co. to object to provisions contained in customers' purchase orders or other communications shall not be deemed a waiver of the terms or conditions hereof, nor acceptance of such provisions.

The above warranty is exclusive, supersedes and is in lieu of all other warranties, expressed or implied, including any implied warranty of merchantability or fitness. No person, agent or dealer is authorized to give any warranties on behalf of the Manufacturer, nor to assume for the Manufacturer any other liability in connection with any of its products unless made in writing and signed by an official of the manufacturer.

ECN/DATE

CPN131287

**106 BRADROCK DRIVE
DES PLAINES, IL. 60018-1967
(847) 299-1188
FAX: (847)299-3061**

ISSUE: **ECN 20730-02/15**

INSTRUCTION DRAWING NUMBER:

P25-**LMFGWARRANTY-5B**

MANUFACTURER'S WARRANTY

LA MARCHE REFERENCE

TABLE OF CONTENTS

1 YEAR (P25-LMFGWARRANTY-1)	
A40R SERIES	BDC
AR COMPONENTS	LDC
ARBS	LMDC

2 YEAR (P25-LMFGWARRANTY-2) (*-2C)		
A18J	A20R	EC*
MSM	RHF	IX

3 YEAR - (P25-LMFGWARRANTY-3)			
A75D/A75DE	A75R	ESCR/II/SP	MSCR

5 YEAR (P25-LMFGWARRANTY-5) (*-5C)			
	A32P/A32S	A45M	
TPSD*	A35M	A75MD	A85MD
	A36D*		

5 YEAR (P25-LMFGWARRANTY-5B)	
	A77D/A77DE

10 YEAR (P25-LMFGWARRANTY-10)	
	A45E
	A48/A48B

10 YEAR (P25-LMFGWARRANTY-10B) (-10C)	
A12B*	A41/A41F*
A40/A40F*	A46/A46F*

1 YEAR – High Frequency - (P25-LMFGWARRANTY-1A)	
A96	A97/A97W/A97R

2 YEAR – High Frequency - (P25-LMFGWARRANTY-2A)	
A63 – PC63	LMHF
LTP	LMPS
TPM – TPC – TPW	TPCD - TPCDB

2 YEAR – (P25-LMFGWARRANTY-2BI)	
BATTERY INFORMER (BI)	

5 YEAR – MAGNETICS ONLY (P25-LMFGWARRANTY-5A)	
A31	

10 YEAR – MAGNETICS ONLY (P25-LMFGWARRANTY-10A)	
A39	
A70B	
AGVB	

90 DAY - (P25-LMFGWARRANTY-90D)	
REFURBISHED UNITS	

* INDICATES EXTENDED WARRANTY OPTION IS AVAILABLE ON THIS MODEL TYPE.

ECN/DATE			
CPN105472			
19297 – 11/11	18985 – 4/11	17939 – 7/08	17486 – 6/07
17348 – 11/06	17046 - 2/06	16976 - 11/05	20730– 2/15
ISSUE: ECN15349 – 04/02			
INSTRUCTION DRAWING NUMBER:			P25-LWARRANTYREFERENCE-1



La MARCHÉ[®]

TABLE OF CONTENTS

FIELD SERVICE RATES

Factory service representatives are available for service on a contract or individual basis in connection with equipment manufactured by La Marche.

Service is normally available on 48 hours' notice, but every effort will be made to provide immediate attention for emergency situations.

Effective – March 1, 2015

FIELD SERVICE RATES ARE PORTAL TO PORTAL

LABOR RATES:

\$150.00/hour	Monday - Friday	8:00 a.m. to 5:00 p.m.
\$225.00/hour	Monday - Friday	5:00 p.m. to 8:00 a.m.
\$225.00/hour	Saturday	
\$300.00/hour	Sundays and Holidays	

LOCAL TRAVEL RATES:

\$75.00/hour	To and from the factory to jobsite +.50 cents per mile
--------------	---

Materials, Lodging, Airfare and Personal Expenses are an additional expense.

International Service Rates are factory quoted on a per need basis with payment in advance.

To arrange for Field Service, call or write the Service Manager at the address below.

IN-HOUSE REPAIRS

LABOR RATES:

\$110.00/hour	Monday - Friday	8:00 a.m. to 5:00 p.m.
---------------	-----------------	------------------------

CPN102527 - PART # P25-LFIELD_SERVICE_RATES – ECN14443; **ECN15624-11/02**

Terms and Conditions of Sale

1. QUOTATIONS:

La Marche Manufacturing Company (hereinafter referred to as La Marche) offers to sell the machinery, tools, equipment, components, parts, or service described in the accompanying written quotation, OR in the invoice on the reverse side issued pursuant to a prior oral quotation, OR in the accompanying confirmation of Buyer's purchase order, OR on the face of the order form taken from La Marche Manufacturing Company's Parts Catalog upon these Terms and Conditions of Sale which shall apply to the exclusion of any inconsistent or additional terms and conditions of Customer's order, acceptance, or acknowledgment. These Terms and Conditions of Sale and the contract formed by acceptance of them cannot be modified, canceled, rescinded, or waived except by a written agreement in which the parties agree specifically to modify, cancel, rescind, or waive any of these terms or provisions signed by both parties, including an authorized officer of La Marche.

2. ACCEPTANCE:

Acceptance of this offer can be made by any commercially reasonable means, including Customer's issuance of an order, acceptance, or acknowledgment or Customer's return of the attached acknowledgment form. Acceptance of this quotation by Customer is expressly limited to the terms and conditions contained in it. If Customer shall use its own purchase order or other form to order goods from La Marche that form shall be used for convenience only and shall evidence Customer's unconditional agreement to these Terms and Conditions of Sale, and any terms or conditions contained in Customer's form inconsistent with or in addition to terms and conditions contained herein shall be of no force or effect whatsoever between the parties.

3. PRICES:

(a) Prices are firm unless otherwise stated in the offer/quotation. Payments made within 10 days of invoice date shall be discounted at the rate shown on the invoice; otherwise net 30 days; past due amounts are subject to service charge of 1% per month or fraction thereof.

(b) The prices do not include any applicable governmental taxes or other charges. Customer shall pay any of these taxes or other charges, together with penalties and expenses, if any, upon receipt of an invoice from La Marche. In lieu of a payment of these taxes, Customer shall provide La Marche with a tax exemption certificate acceptable to the taxing authorities.

(c) Unless otherwise quoted by La Marche all prices are F.O.B. La Marche Manufacturing Company, Des Plaines, Illinois.

(d) All catalog prices are subject to change without notice.

(e) Freight will be prepaid and billed as a separate item on the invoice. All extra charges for special handling, packaging and demurrage are obligations of the Buyer and will be billed as such.

(f) Goods not manufactured by La Marche will be invoiced at the prices stated in the quotation, subject to increase in prices of any of these goods by La Marche's suppliers.

(g) La Marche reserves the right to refuse to extend credit at any time, regardless of prior dealings, and for any reason; in such cases items will be shipped C.O.D.

(h) Customer shall reimburse La Marche for all costs and expenses, including attorneys' fees and court costs, incurred in collecting any amounts due.

4. COMPLETION-DELIVERY:

(a) The proposed delivery date and performance schedule stated in the quotation is a best estimate at the time of quotation and is not binding on La Marche. Unless otherwise stated, goods quoted as "In stock" are subject to prior sale. La Marche hereby rejects any attempt to impose a penalty or other burden on the failure to deliver on the date set forth in the quote or offer or acceptance.

(b) La Marche shall have no liability to customers or any third party for any loss, damage, or expense from any delay or failure of performance due to any cause beyond the control of La Marche, including, but not limited to, fire, strike, accident, war conditions, government regulation or restriction, shortages in transportation, power, labor or material, freight embargo, riot or civil commotion, default of the supplier, or prohibitions or events which render performance difficult or impossible.

(c) Upon giving notice to a customer of a delay in accordance with the Illinois Uniform Commercial Code, La Marche shall allocate all goods produced by La Marche among the then customers of La Marche in proportion to the contracts then received.

(d) Unless otherwise set forth or subsequently agreed to in writing, La Marche has complete discretion in specifying the manner of shipment even though Buyer is paying full cost thereof.

5. TITLE AND DELIVERY:

Delivery of goods to a carrier by La Marche F.O.B. La Marche's plant, Des Plaines, Illinois, consigned to Customer or its order, as Customer may direct, shall be complete delivery to Customer as well as transfer to Customer of title, ownership, and possession of and to the goods. Customer assumes risk of loss, damage, or shortage in transit and shall be responsible for pursuing all claims with the carrier or carrier's insurer. Customer shall provide La Marche with written notice of any shortage, loss or damage within five (5) days of receipt of the goods.

6. SERVICES PERFORMED:

If customer has requested La Marche to service and repair any machinery or equipment (Work), Customer shall provide a safe area in which La Marche's employees, agents, or contractors may perform the Work and Customer shall be responsible for the safety of all persons on, about, or adjacent to areas where the Work is performed. Customer shall furnish to La Marche all necessary work tools, equipment, and supplies.

7. COOPERATION, CHANGES, OR CANCELLATIONS:

(a) Customer shall at all times cooperate with La Marche and furnish any specifications, drawings, or information requested by La Marche within a reasonable time after any request. La Marche and its agents and employees are under no obligation whatsoever to treat as confidential any disclosure made by Customer in connection with this or other transactions with La Marche.

(b) Customer shall not countermand, cancel, or change the order or cause the work or shipment to be delayed or stopped except with the consent of, and upon the terms agreed to, by La Marche.

(c) No goods can be returned to La Marche without prior written approval. All returned goods are subject to La Marche's usual and customary restocking fee. Special made items are not returnable.

8. PERFORMANCE BY LA MARCHÉ:

In the event of any proceedings filed by or against Customer, voluntary or involuntary, in bankruptcy or insolvency, or for appointment of a receiver or trustee, or an assignee for the benefit of creditors, La Marche shall have the right to discontinue work on the offer and receive full reimbursement for all costs incurred plus a reasonable profit. If La Marche, in its sole discretion, in good faith, is insecure as to customer's payment or performance, it may refuse to perform until it receives adequate assurances of customer's payment or performance.

9. INSTALLATION:

Unless otherwise specifically agreed by La Marche, Customer shall install all goods, and La Marche shall bear no expense of installation.

10. WARRANTY:

Depending on the model, for a period of at least one (1) year from the date of shipment, La Marche warrants that the goods manufactured and the services performed by it shall be free from defects in material and workmanship.

NOTWITHSTANDING ANY PROVISION OF THESE TERMS AND CONDITIONS, THE WARRANTY CONTAINED IN THIS PARAGRAPH, AS LIMITED IN IT, IS THE ONLY WARRANTY EXTENDED BY LA MARCHÉ IN CONNECTION WITH ANY SALE BY IT AND IS EXTENDED TO CUSTOMER ONLY AND NOT TO ANY SUCCESSIVE BUYERS, USERS, THIRD PARTIES, OR EMPLOYEES AND IS IN LIEU OF ALL OTHER WARRANTIES, EXPRESS OR IMPLIED, INCLUDING WARRANTIES OF MERCHANTABILITY AND FITNESS FOR A PARTICULAR PURPOSE.

11. REMEDIES:

La Marche's obligations under these Terms and Conditions upon breach of warranty or other provision shall be limited, at La Marche's election, to the repair or replacement of goods or the crediting to the Customer of an amount not to exceed the purchase price of the goods. If notice of a breach of warranty is given by Customer, La Marche shall be obligated only to repair, replace, or credit the purchase price for

goods which examination by La Marche or its representatives shall disclose to have been defective under ordinary and normal use. Written notice of any defect shall be given by Customer to La Marche at 106 Bradrock Dr., Des Plaines, Illinois, within thirty (30) days after the defect appears. No allowance shall be made for any expenses incurred by Customer in repairing defective parts or supplying any missing parts except on the written consent of La Marche. In any case, if La Marche agrees to replace or repair a defective part, Customer shall have the responsibility and bear the cost for and related to procuring and providing all necessary dismantling, reassembling, and handling facilities in connection with these services.

12. LIMITATION OF DAMAGES:

In no event shall La Marche have any liability whatsoever for payment of any consequential, incidental, indirect, special, or tort damages of any kind, including, but not limited to, any loss of profits.

13. CUSTOMER RESPONSIBILITY-INDEMNITY:

(a) Customer assumes and shall bear sole responsibility for providing adequate and efficient safeguards, work-handling tools, and safety devices necessary to provide a safe work place and to protect fully all personnel from bodily injury or death which otherwise may result from the use, operation, setup or maintenance of the goods. Compliance with the Occupational Safety and Health Act and the regulations adopted under it and with other prevailing federal, state, and local codes and industry-accepted standards is the responsibility of Customer. La Marche shall bear no responsibility whatsoever for the failure of Customer to order, install, or use safeguards, work-handling tools, or safety devices. Customer shall establish, and require all persons who use, operate, set up, or maintain the goods to use all proper and safe operating procedures, including, but not limited to, procedures set forth in any manuals or instruction sheets relating to the goods. Customer shall not remove or modify any devices, warning signs or manuals furnished with or installed upon or attached to the goods.

(b) Customer releases all actions (including, but not limited to, any action for injury to or death of any person or damage to property) arising out of the manufacture, sale, use, or operation of the goods which Customer may have any time against La Marche or its agents or employees. Customer covenants to indemnify and hold harmless La Marche and its agents and employees of, from, and against any and all loss, damage, expense (including reasonable attorneys' fees, claims, suits, or liability) which La Marche or any of its agents or employees may sustain or incur at any time, for or by reason of any injury to or death of any person or damage to any property arising out of any claimed or actual breach by Customer of Customer's undertaking under Paragraph 13 (a) or any acts primarily attributable to the conduct of Customer or its employees and agents, including, but not limited to, the negligence or reckless conduct of Customer's employees or agents, Customer's maintenance of the goods, Customer's addition to or modification of the goods, or Customer's use of the goods in an inappropriate manner.

(c) Customer shall notify La Marche promptly, in writing, and in all events within ten (10) days after its occurrence, of any accident or malfunction involving any goods which results in injury to or death of persons, including Customer's agents and employees, or damage to property, including Customer's property, or the loss of use of any property, and Customer shall cooperate fully with La Marche in investigating and determining the cause of any such accident or malfunction.

14. PATENTS:

(a) La Marche will defend and save Customer harmless from and against any loss or expense caused by any claimed infringement of any United States patent arising out of the purchase, sale, or use of goods designed and manufactured by La Marche in the event Customer gives La Marche prompt, written notice of any claim of infringement and complete authority in defending against it. Notwithstanding La Marche's indemnity, Customer releases any claims Customer may have at any time against La Marche for consequential damages or loss of profits to Customer resulting from any suit regarding the use of La Marche's goods or any part of them. Customer shall give La Marche any reasonable assistance in defense of any claimed infringement as it shall be able to give and shall not charge La Marche for the costs of that assistance. If the goods or any part of them designed and manufactured by La Marche are held to infringe any United States patent and the use is enjoined, La Marche shall, at its own expense, in lieu of all other liability, either procure for Customer the right to continue using the goods, replace the goods with non-infringing goods, modify the goods so as to become non-infringing, or return the purchase price. NOTWITHSTANDING ANYTHING IN THESE TERMS AND CONDITIONS TO THE CONTRARY, LA MARCHÉ'S LIABILITY UNDER THIS PARAGRAPH 14 SHALL BE LIMITED TO THE PURCHASE PRICE AND THE TRANSPORTATION AND INSTALLATION COSTS OF THE GOODS. La Marche grants no license express or implied other than the right of Customer to use the goods in the form delivered by La Marche.

(b) Customer will defend, protect and save La Marche harmless from and against any loss or expense incident to any claimed infringement of any United States patent arising out of the manufacture, service, or sale of goods or any parts of them which are manufactured or serviced by La Marche but which are not designed by La Marche.

15. APPLICABLE LAW:

These Terms and Conditions of Sale shall be construed in accordance with the law of the State of Illinois.

16. SUCCESSORS:

La Marche's quotation and these Terms and Conditions shall inure to the benefit of, and be binding upon, the successors of the parties to them.

17. LIMITATION ON ACTION:

Any action or suit against La Marche arising in any way from the quotation or with respect to the goods must be commenced within one (1) year after the cause of action has occurred.

18. SEVERABILITY:

The invalidity of any segment of these Terms and Conditions shall in no way operate to invalidate any other portion and, except for the invalid segment, the entire balance of these Terms and Conditions shall be and remain in full force and effect.

19. WHOLE AGREEMENT:

All previous oral and written communications of the parties for the sale of goods are abrogated. The parties agree that there are no other agreements or warranties, except as contained in these Terms and Conditions and the accompanying quotation. These Terms and Conditions and the accompanying quotation are the final, complete and exclusive expression of the parties' agreement.

20. WAIVER:

No waiver of performance required by Customer shall be valid unless in writing signed by a duly authorized officer of La Marche. No waiver of a specific action shall be construed as a waiver of future performance.